

MI12-00L Series

User's Manual

NO. G03-MI12-00L-F

Revision: 2.0

Release date: September 30, 2022

Trademark:

*** Specifications and Information contained in this documentation are furnished for information use only, and are subject to change at any time without notice, and should not be construed as a commitment by manufacturer.**

Environmental Protection Announcement

Do not dispose this electronic device into the trash while discarding. To minimize pollution and ensure environment protection of mother earth, please recycle.



TABLE OF CONTENT

ENVIRONMENTAL SAFETY INSTRUCTION	iv
USER'S NOTICE	v
MANUAL REVISION INFORMATION	v
ITEM CHECKLIST	v
CHAPTER 1 INTRODUCTION OF THE MOTHERBOARD	
1-1 FEATURE OF MOTHERBOARD	1
1-2 SPECIFICATION	2
1-3 LAYOUT DIAGRAM	4
CHAPTER 2 HARDWARE INSTALLATION	
2-1 JUMPER SETTING.....	9
2-2 CONNECTORS AND HEADERS	14
2-2-1 CONNECTORS	14
2-2-2 HEADERS.....	18
CHAPTER 3 INTRODUCING BIOS	
3-1 ENTERING SETUP.....	25
3-2 BIOS MENU SCREEN	26
3-3 FUNCTION KEYS.....	27
3-4 GETTING HELP.....	27
3-5 MEMU BARS	28
3-6 MAIN MENU	29
3-7 ADVANCED MENU	30
3-8 CHIPSET MENU	41
3-9 SECURITY MENU.....	44
3-10 BOOT MENU	46
3-11 SAVE & EXIT MENU	47



Environmental Safety Instruction

- Avoid the dusty, humidity and temperature extremes. Do not place the product in any area where it may become wet.
- 0 to 60 centigrade is the suitable temperature. (The figure comes from the request of the main chipset)
- Generally speaking, dramatic changes in temperature may lead to contact malfunction and crackles due to constant thermal expansion and contraction from the welding spots' that connect components and PCB. Computer should go through an adaptive phase before it boots when it is moved from a cold environment to a warmer one to avoid condensation phenomenon. These water drops attached on PCB or the surface of the components can bring about phenomena as minor as computer instability resulted from corrosion and oxidation from components and PCB or as major as short circuit that can burn the components. Suggest starting the computer until the temperature goes up.
- The increasing temperature of the capacitor may decrease the life of computer. Using the close case may decrease the life of other device because the higher temperature in the inner of the case.
- Attention to the heat sink when you over-clocking. The higher temperature may decrease the life of the device and burned the capacitor.

USER'S NOTICE

COPYRIGHT OF THIS MANUAL BELONGS TO THE MANUFACTURER. NO PART OF THIS MANUAL, INCLUDING THE PRODUCTS AND SOFTWARE DESCRIBED IN IT MAY BE REPRODUCED, TRANSMITTED OR TRANSLATED INTO ANY LANGUAGE IN ANY FORM OR BY ANY MEANS WITHOUT WRITTEN PERMISSION OF THE MANUFACTURER.

THIS MANUAL CONTAINS ALL INFORMATION REQUIRED TO USE THIS MOTHER-BOARD SERIES AND WE DO ASSURE THIS MANUAL MEETS USER'S REQUIREMENT BUT WILL CHANGE, CORRECT ANY TIME WITHOUT NOTICE. MANUFACTURER PROVIDES THIS MANUAL "AS IS" WITHOUT WARRANTY OF ANY KIND, AND WILL NOT BE LIABLE FOR ANY INDIRECT, SPECIAL, INCIDENTAL OR CONSEQUENTIAL DAMAGES (INCLUDING DAMAGES FOR LOSS OF PROFIT, LOSS OF BUSINESS, LOSS OF USE OF DATA, INTERRUPTION OF BUSINESS AND THE LIKE).

PRODUCTS AND CORPORATE NAMES APPEARING IN THIS MANUAL MAY OR MAY NOT BE REGISTERED TRADEMARKS OR COPYRIGHTS OF THEIR RESPECTIVE COMPANIES, AND THEY ARE USED ONLY FOR IDENTIFICATION OR EXPLANATION AND TO THE OWNER'S BENEFIT, WITHOUT INTENT TO INFRINGE.

Manual Revision Information

Reversion	Revision History	Date
2.0	Second Edition	September 30, 2022

Item Checklist

- Motherboard
- Cable(s)

Chapter 1

Introduction of the Motherboard

1-1 Feature of Motherboard

- Intel® Apollo Lake series SoC Processor, with low power consumption never denies high performance
- 1* SO-DIMM slot supports 1* 1866 MHz DDR3L SO-DIMM, up to 8GB
- C-media USB Audio
- 1* 10/100/1000 based-TX Ethernet ports
- Onboard 1* SATAIII port & 1* M.2 Socket 3 slot for M-Key type 2242/2260 SATA SSD
- Support HDMI/LVDS or eDP multiple-Display solution (optional)
- Support 2* COM port expansion
- 4* External USB 3.0 & 2* Internal USB 2.0
- Onboard 1* full-size Mini-PCIE slot & 1* SIM card slot
- 1* Internal PS2 Keyboard & Mouse pin header
- Compliance with ERP standard
- Support Watchdog function
- Support TPM function (optional)
- Solution for Digital Signage, POS & Industrial Automation

1-2 Specification

Spec	Description
Design	<ul style="list-style-type: none">● Mini-ITX form factor; PCB size: 17.0x17.0cm
CPU	<ul style="list-style-type: none">● Intel® Apollo Lake *SoC CPU <p><i>*CPU model varies from different IPC options. Please consult your dealer for more information of onboard CPU.</i></p>
Memory	<ul style="list-style-type: none">● 1* DDR3L SO-DIMM slot● Support DDR3L 1866 MHz SO-DIMM up to 8GB
Expansion Slot	<ul style="list-style-type: none">● MPE1: 1* full-size Mini-PCIE slot● SIMCARD: 1* SIM card slot <p><i>* Note: SIMCARD slot only work when compatible SIM card installed & 3G LAN card installed in full-size Mini-PCIE (MPE1) slot.</i></p>
Storage	<ul style="list-style-type: none">● 1* SATAIII 6Gb/s port● 1* M.2 Socket 3 slot (M2, M-key, support type-2242 /2260 SATA SSD)
LAN Chip	<ul style="list-style-type: none">● 1* RTL8111H GbE● Support Fast Ethernet LAN function of providing 10/100/1000Mbps Ethernet data transfer rate
Audio Chip	<ul style="list-style-type: none">● C-media USB Audio integrated
BIOS	<ul style="list-style-type: none">● AMI Flash ROM
Rear I/O	<ul style="list-style-type: none">● 1* DCIN (12V) Power Jack● 1* 1.0GbE RJ-45 LAN port● 2* HDMI ports● 4* USB3.0 ports● 1* Line-out port

Internal I/O	<ul style="list-style-type: none">● 1* Front panel header● 1* 9-pin USB 2.0 header● COM1/2: 2* 9-pin Serial port header● 1* LAN activity LED header● 1* PS2 Keyboard & Mouse header● 1* Front panel audio header● 1* 10-pin GPIO header● 1*SMBUS header● 1* Front panel buzzer header● 1* LVDS header (*Selectable with eDP)● 1* EDP header (*Selectable with LVDS)● 1* LVDS/eDP inverter header
---------------------	---

Note:

1. The module should be **DDR3L 1.35V SODIMM** and **not exceeding 8GB total capacity**.
2. The SODIMM installed should be of or above the memory clock the model supported, otherwise the board will not start.

1-3 Layout Diagram

Rear IO Panel Diagram:

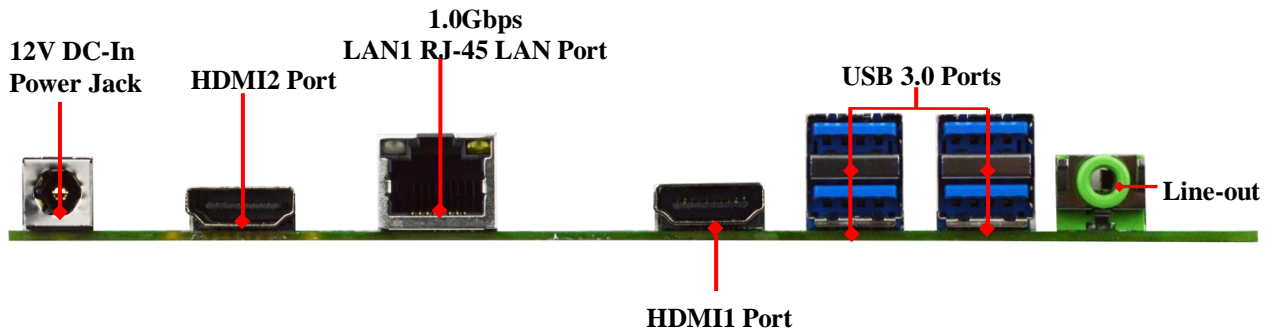

Warning!!The board has a 12V DC-in power connector (**DCIN3**) in I/O back panel and an internal 12V power connector (DCIN2). User can only connect one type of compatible power supply to one of them to power the system.

Motherboard Internal Diagram

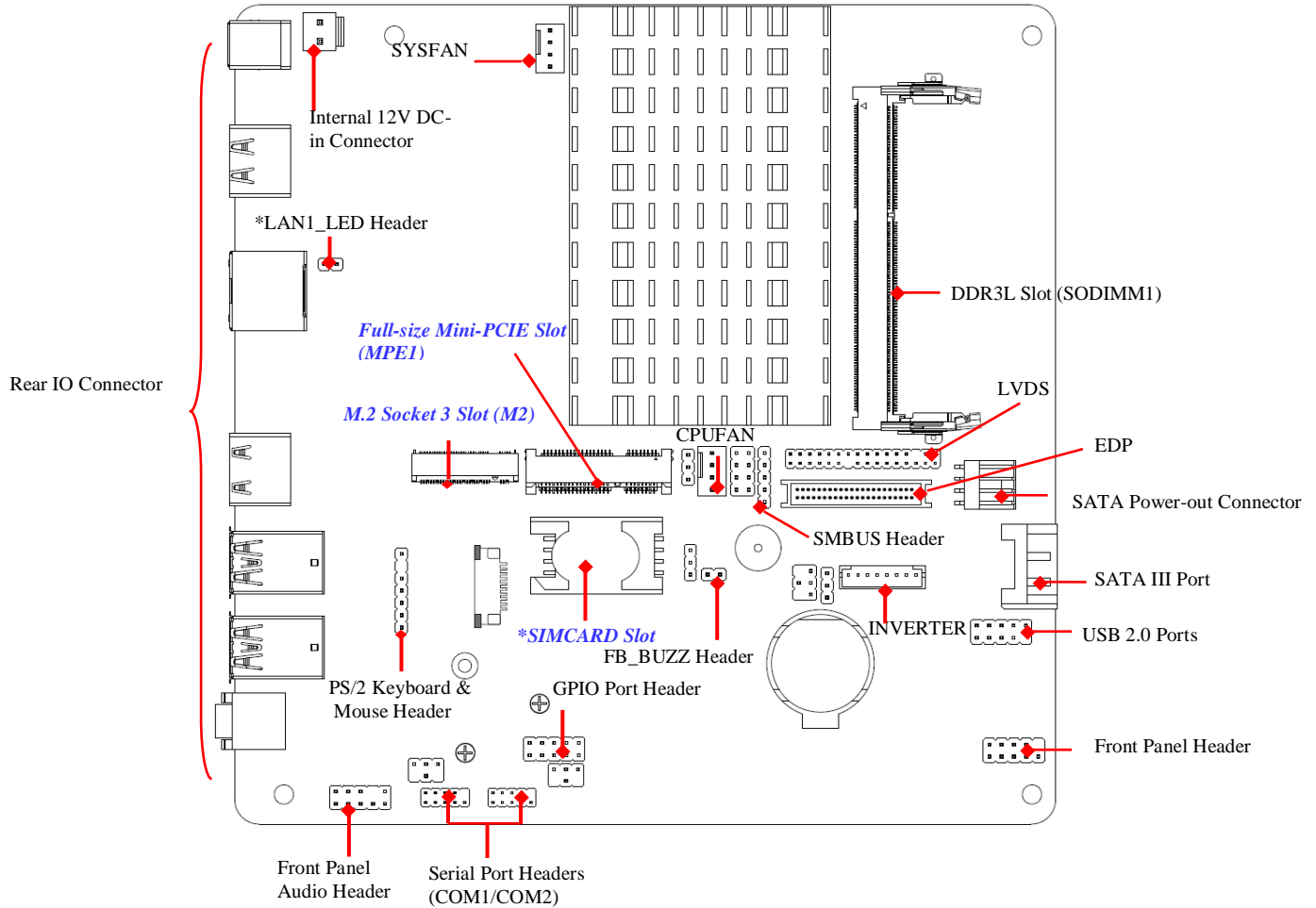

Note: SIMCARD slot only work when compatible SIM card installed & 3G LAN card installed in full-size Mini-PCIE (MPE1) slot.

Jumper Positions:

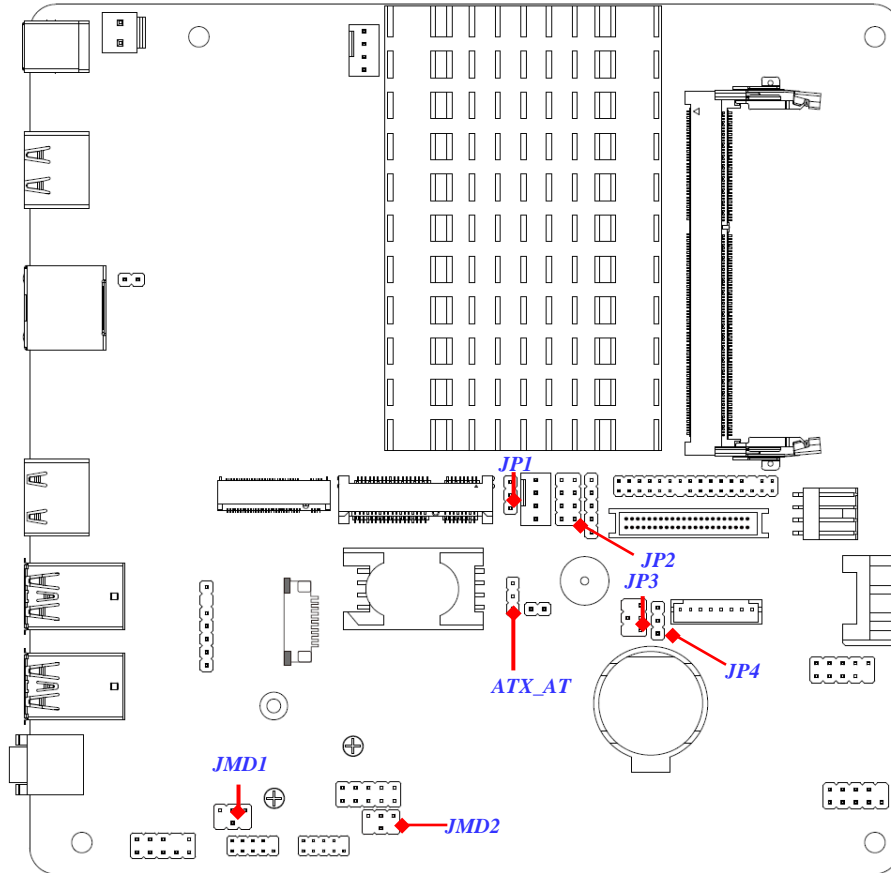

Jumper

Jumper	Name	Description
JMD1	COM1 Serial Port Power Select	4-pin Block(2.54 pitch)
JMD2	COM2 Serial Port Power Select	4-pin Block(2.54 pitch)
JP1	MPE1 Mini-PCIE Power 3VSB / 3.3V Select	3-Pin Block(2.54 pitch)
ATX_AT	ATX Mode / AT Mode Select	3-Pin Block(2.54 pitch)
JP4	LVDS/EDP Inverter Power 3.3V/5V/12V Select	3-pin Block(2.54 pitch)
JP3	LVDS/EDP Panel Power 3.3V/5V/12V Select	4-pin Block(2.54 pitch)
JP2	Pin 1&2: CASE OPEN Pin 3&4: TXE Override Pin 5&6: Clear CMOS Pin 7&8: Clear ME_RTC	8-pin Block(2.54 pitch)

Connectors

Connector	Name
DCIN3	12V DC input Power Jack
HDMI2	HDMI Port Connector
LAN1	1.0GbE RJ-45 LAN Port Connector
HDMI1	HDMI Connector
USB31	USB3.0 Port Connector
USB32	USB3.0 Port Connector
FP_HP	Top: Audio Line-out Port Connector
DCIN2	Internal 12V DC-in Power Connector
SATA1	SATAIII Port Connector

SATAPW	SATA Power Connector
CPUFAN	CPU Fan Connector
SYSFAN	System Fan Connector

Headers

Header	Name	Description
FP	Front Panel Header (PWR LED/ HDD LED/Power Button /Reset)	9-pin Block(2.54 pitch)
F_USB1	USB 2.0 Header	9-pin Block(2.54 pitch)
COM1	RS232/422/485 Serial Port Header	9-pin Block(2.0 pitch)
COM2	RS232 Serial Port Header	9-pin Block(2.0 pitch)
LAN1_LED	LAN Activity LED Header	2-pin Block(2.54 pitch)
PS2KBMS	PS2 keyboard & Mouse Header	6-pin Block(2.54 pitch)
FP_AUDIO	Front Panel Audio Header	9-pin Block(2.54 pitch)
GPIO	GPIO Port Header	10-pin Block(2.54 pitch)
SMBUS	SMBUS Header	5-pin Block(2.54 pitch)
FP_BUZZ	Buzzer Header	2-pin Block(2.54 pitch)
INVERTER	LVDS INVERTER	8-pin Block(2.54 pitch)
EDP	EDP Wafer	40-pin Block(1.25 pitch)
LVDS	LVDS Header	30-pin Block(2.0 pitch)

Chapter 2

Hardware Installation

2-1 Jumper Setting

(1) **JMD1 (4-pin): COM1 Port Pin9 Function Select** (2.54 pitch)

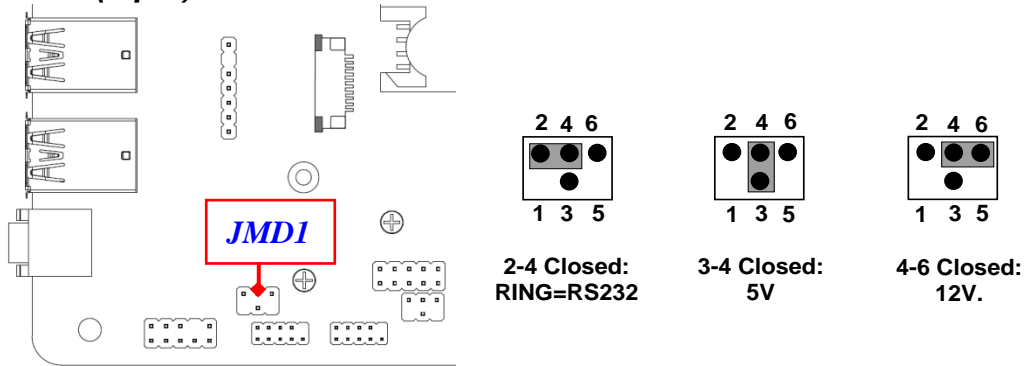

(2) **JMD2 (4-pin): COM2 Header Pin9 Function Select** (2.54 pitch)

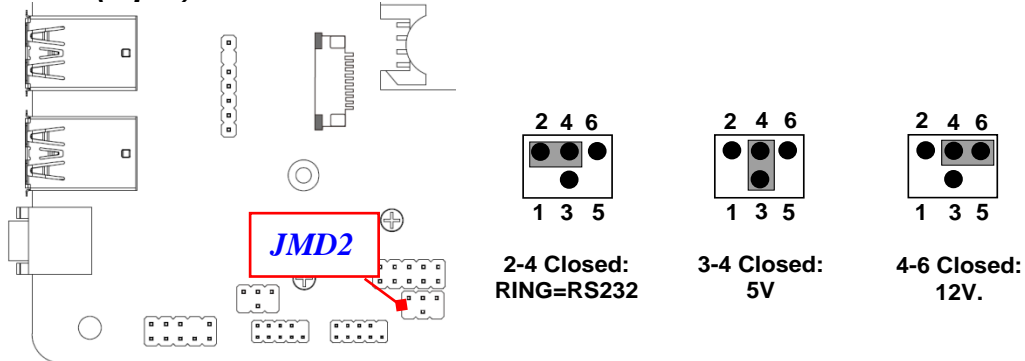

(3) JP1 (3-pin): MPE1 Mini-PCIE Slot Power VCC3.3V/3VSB Select (2.54 pitch)

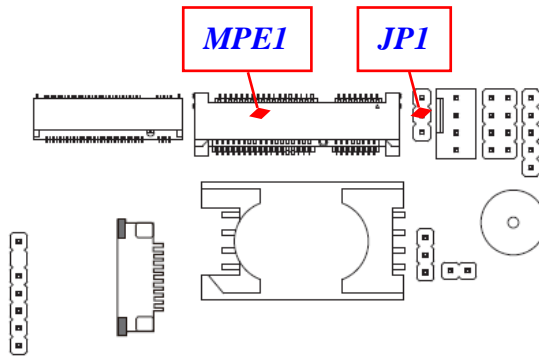

1-2 Closed: MPE1 VCC=
3.3V(Default);

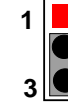

2-3 Closed: MPE1 VCC=3VSB.

(4) ATX_AT (3-pin): AT/ATX Mode Select (2.54 pitch)

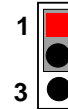
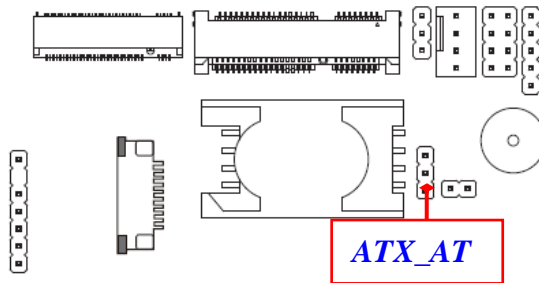

1-2 Closed: ATX Mode(Default);



2-3 Closed: AT Mode

***ATX Mode Selected:** Press power button to power on after power input ready;
AT Mode Selected: Directly power on as power input ready.

(5) JP4 (3-pin): LVDS / EDP Inverter Backlight VCC 5V/12V Select (2.54 pitch)

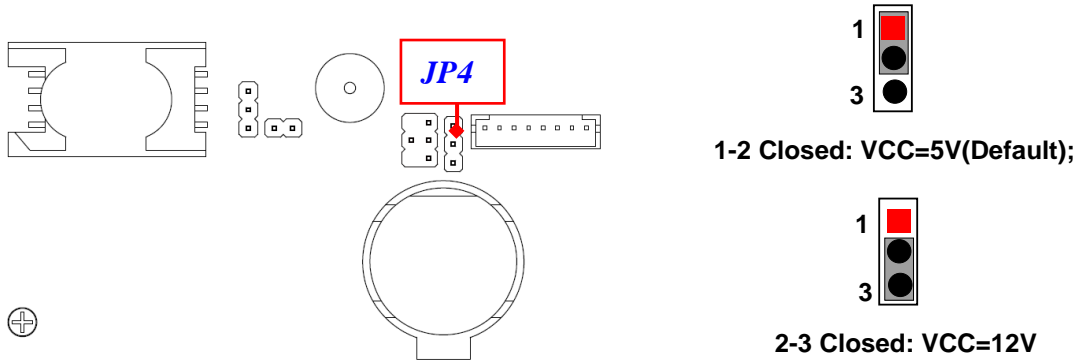

(6) JP3 (4-pin): LVDS / EDP Panel VCC 3.3V/5V/12V Select (2.54 pitch)

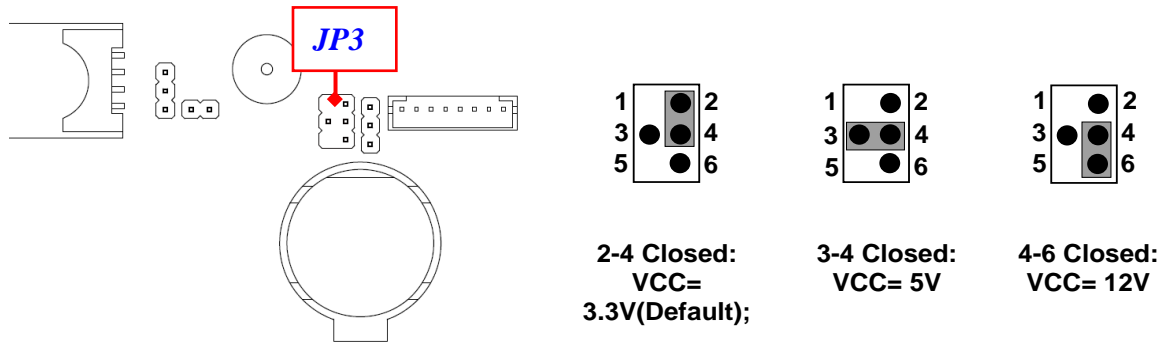

(7) JP2 (8-pin): Jumper Combo Block (2.54 pitch)

Pin 1&2 of JP2 (8-pin): Case Open Message Display Function Select

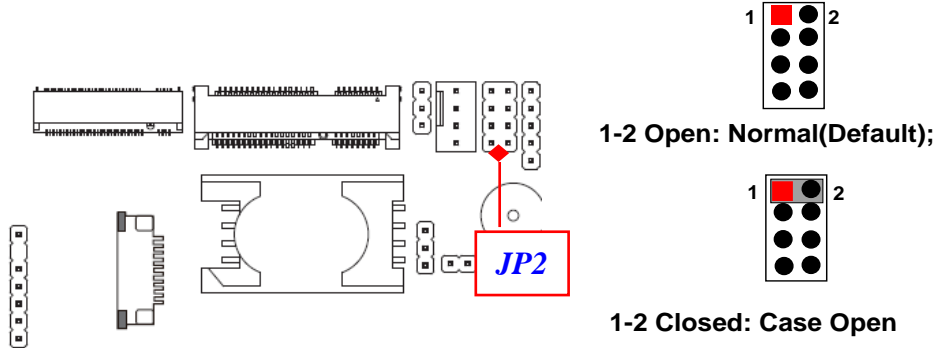

Pin (1-2) Close: When Case Open function pin short to GND, the Case Open function was detected. When Used, needs to enter BIOS and enable '**Case Open Detect**' function. In this case if your case is removed, next time when you restart your computer, a message will be displayed on screen to inform you of this.

Pin 3&4 of JP2 (8-pin): TXE Override Setting (2.54 pitch)

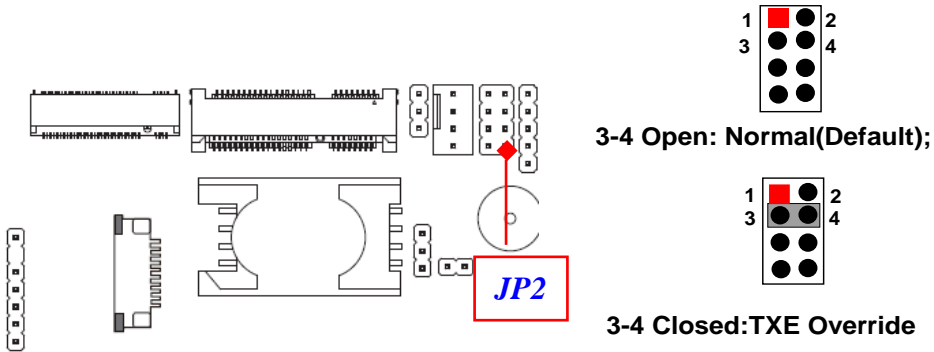

Pin 5&6 of JP2 (8-pin): Clear CMOS (2.54 pitch)

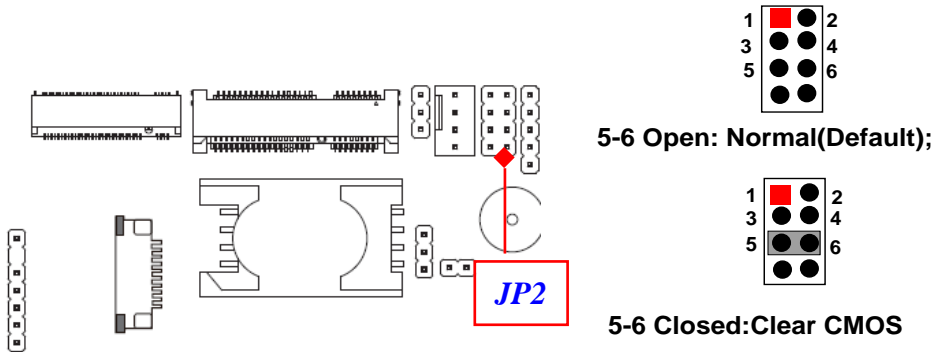

Pin 7&8 of JP2 (8-pin): Clear ME_RTC (2.54 pitch)

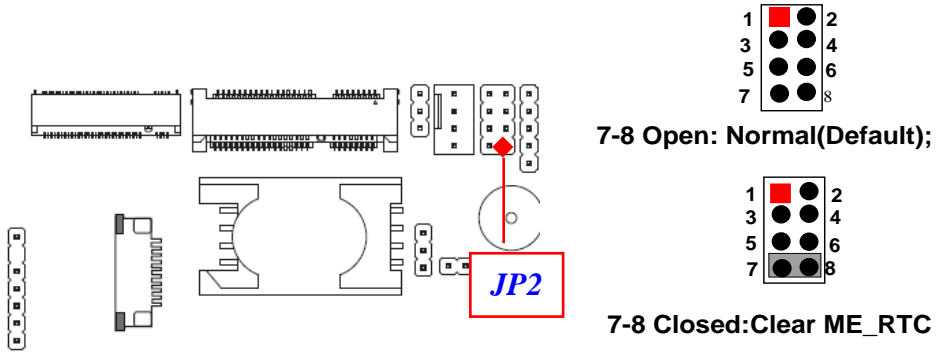



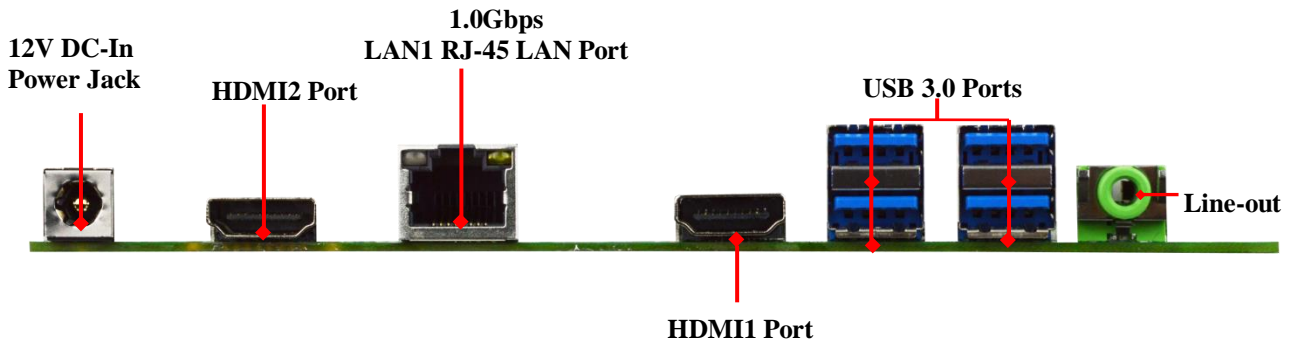

2-2 Connectors and Headers

2-2-1 Connectors



(1) Rear I/O Connectors

Icon	Name	Function
	Power Jack	12V DC—in system power connector For user to connect compatible power adapter to provide power supply for the system.
	HDMI Port	To connect display device that support HDMI specification.
	1.0Gbps RJ-45 LAN Port	This connector is standard RJ-45 LAN jack for Network connection. Which supports 10/100/1000 Mbps Ethernet data transfer rate.
	USB 3.0 Port	To connect USB keyboard, mouse or other devices compatible with USB specification. USB 3.0 ports supports up to 5Gbps data transfer rate.
	Line-Out	This connector can functions as audio Line-Out jack and MIC jack with compatible cables & devices.

For 1.0Gbps RJ-45 LAN port:

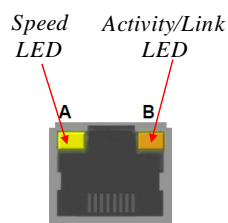

A: Speed LED

Status	Description
Off	10Mbps connection
Green	100Mbps connection
Orange	1Gbps connection

B: Activity/Link LED

Status	Description
Off	No Link
Blinking	Data Activity
On	Link

(2) DCIN2 (2-pin): Internal 12V DC-in power connector

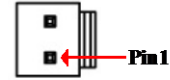
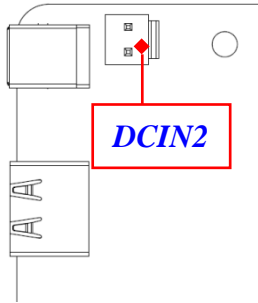

Pin No.	Definition
1	+12V DC_IN
2	GND

Warning!!

The board has a 12V DC-in power jack (**DCIN3**) in I/O back panel and an internal 12V power connector (**DCIN2**). User can only connect one type of compatible power supply to one of them to power the system.

(3) SATA1 (7-pin block):SATAIII Port connector

This connector is a high-speed SATAIII port that supports 6 GB/s transfer rate.

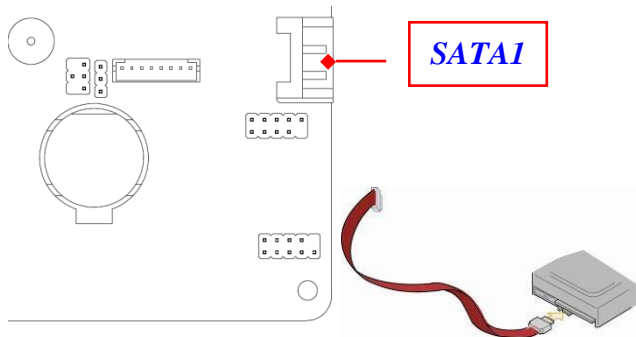

Pin No.	Definition
1	GND
2	TXP
3	TXN
4	GND
5	RXN
6	RXP
7	GND

(4) SATAPW (4-pin) : SATA Power-out Connector

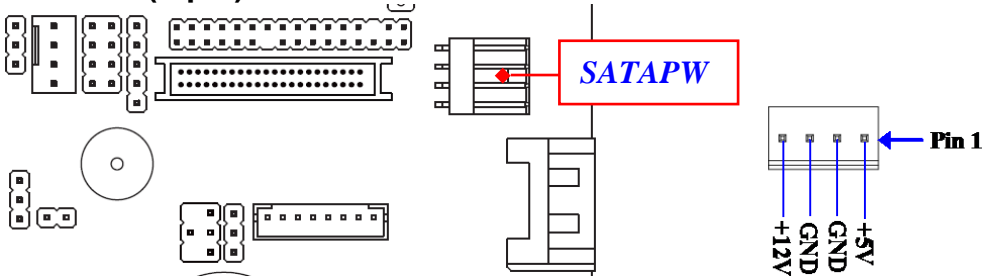

(5) CPUFAN (4-pin): CPU FAN Connector

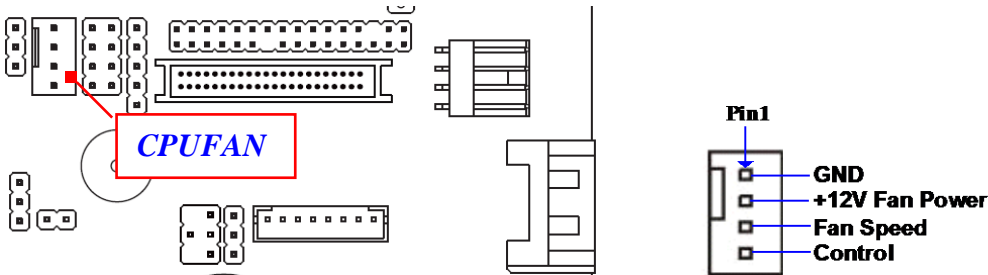

(6) SYSFAN (4-pin): FAN Connector

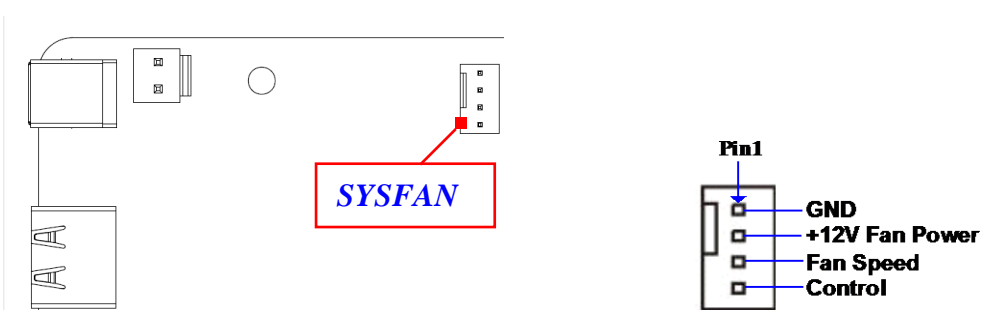

2-2-2 Headers

***Notice:** The following diagrams serves as illustration purpose only. Some of the headers are only optional. In the case of any differences please refer to the model you purchased for actual specifications.

(1) FP (9-pin): Front Panel Header (2.54 pitch)

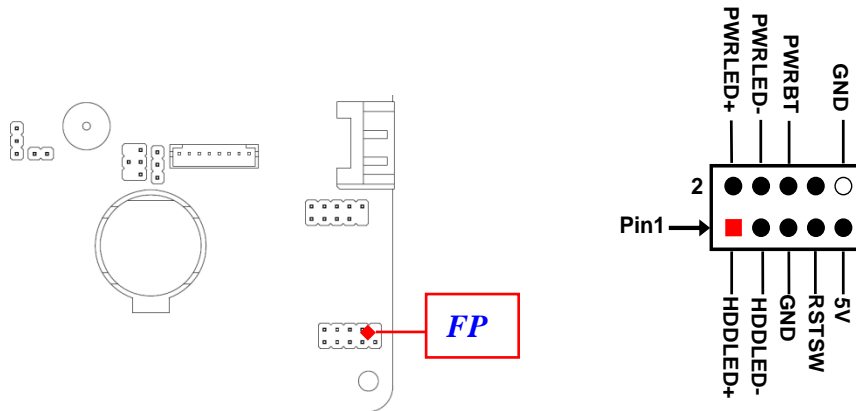

(2) F_USB1 (9-pin): USB 2.0 Port Header (2.54 pitch)

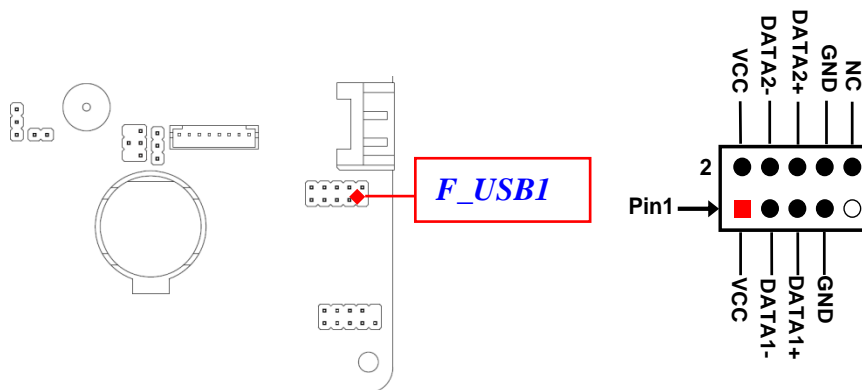

(3) COM1/COM2 (9-pin): RS232 Serial Port Header (2.0 pitch)

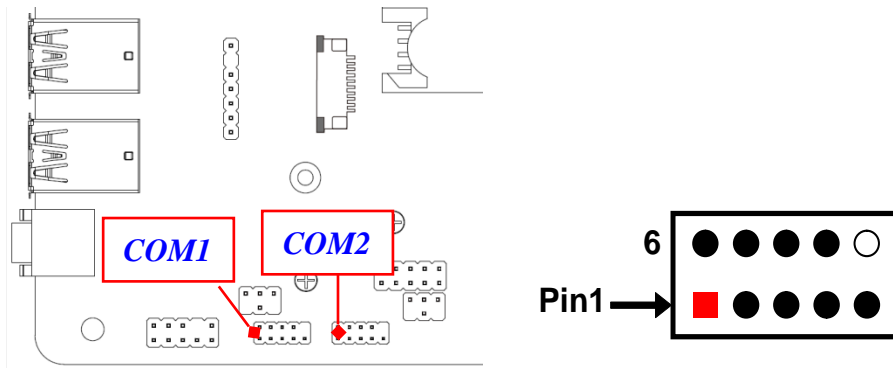

Pin NO.	RS232
Pin 1	DCD
Pin 2	RXD
Pin 3	TXD
Pin 4	DTR
Pin 5	GND
Pin 6	DSR
Pin 7	RTS
Pin 8	CTS
Pin 9	RI

(4) LAN1_LED (2-pin): LAN Activity LED Header (2.54 pitch)

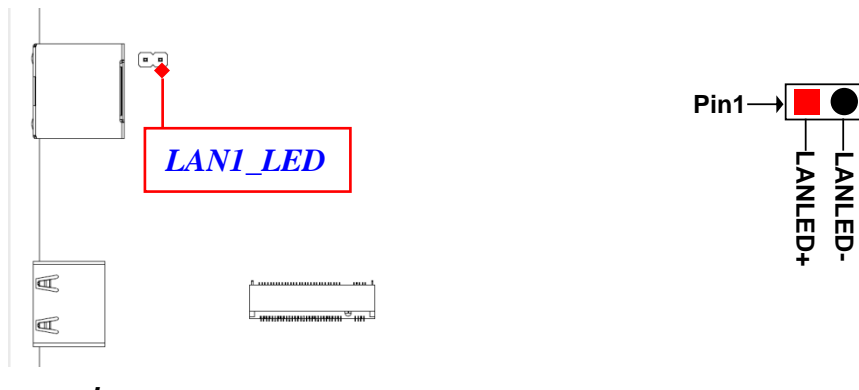

(5) PS2KBMS (6-pin): PS/2 Keyboard & Mouse Header (2.54 pitch)

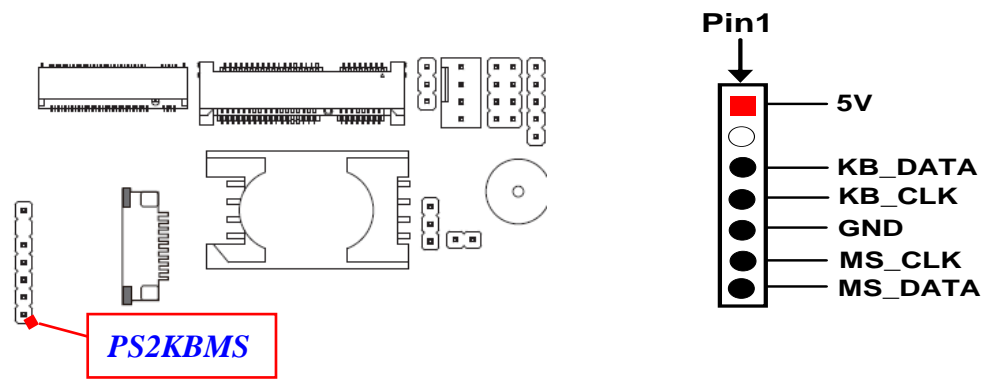

(6) FP_AUDIO (9-pin): Line-Out, MIC-In Header (2.54 pitch)

This header connects to Front Panel Line-out, MIC-In connector with cable.

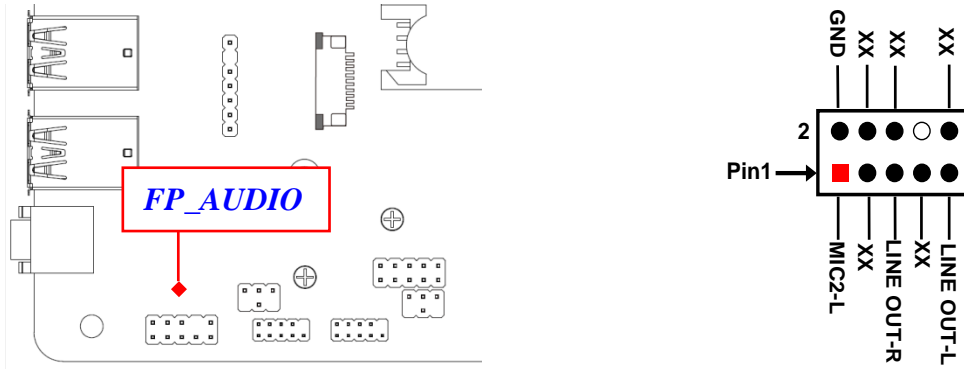

(7) GPIO (10-pin): GPIO Header (2.54 pitch)

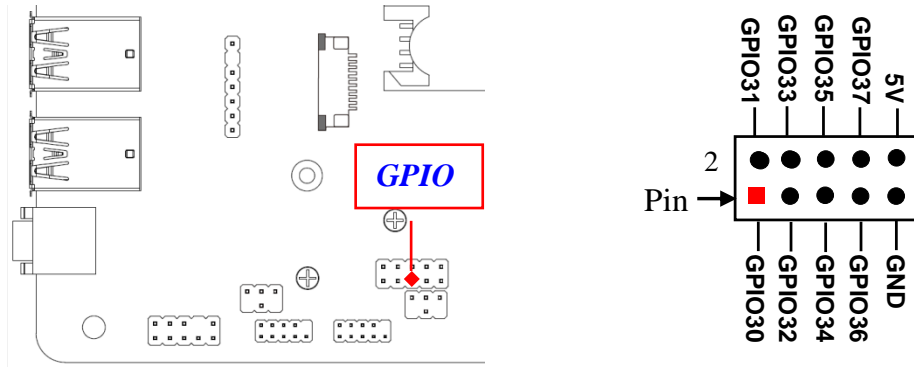

(8) SMBUS (5-pin): SMBUS Header (2.54 pitch)

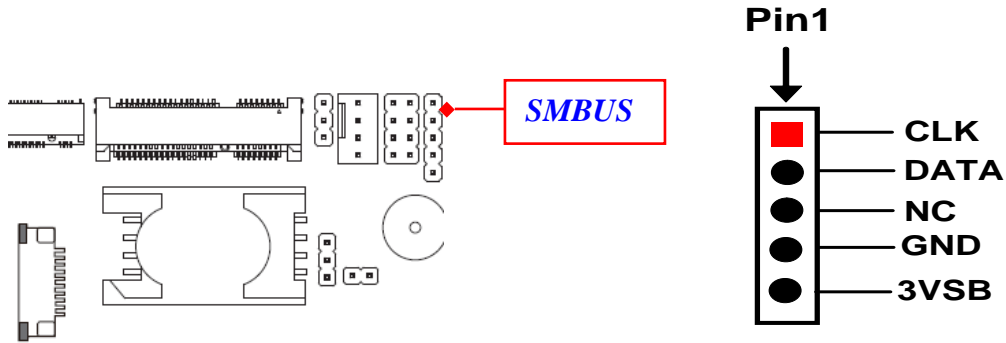

(9) FP_BUZZ (2-pin): Buzzer Header (2.54 pitch)

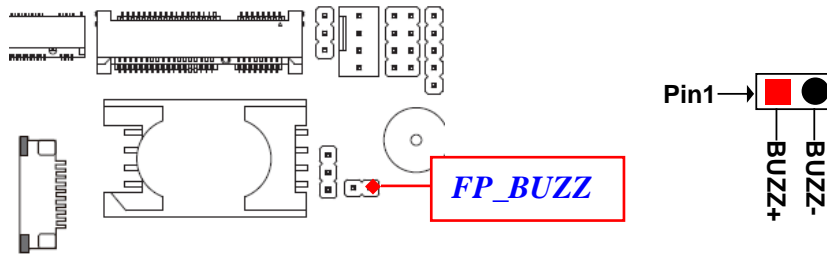

(10) INVERTER (8-pin): LVDS Inverter Connector (2.0 pitch)

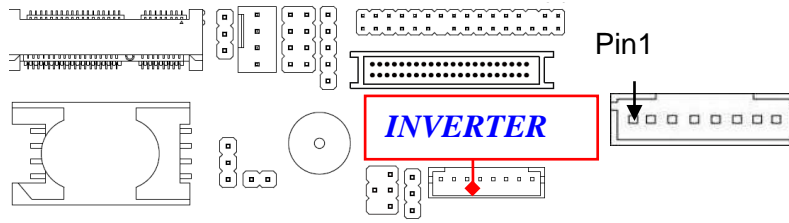

Pin No.	Definition
1	Backlight Enable
2	Backlight PWM
3	Back Light LED VCC
4	Back Light LED VCC
5	GND
6	GND
7	Backlight Up SW
8	Backlight Down SW

Warning! Find Pin-1 location of the inverter and make sure that the installation direction is correct! Otherwise serious harm will occur to the board/display panel!!!

(11) EDP (40-pin): EDP wafer (1.25 pitch)

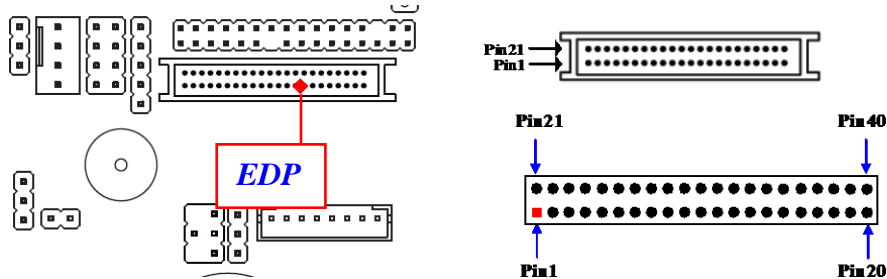

Pin NO.	Pin Define	Pin NO.	Pin Define
Pin 1	XX	Pin 21	XX
Pin 2	GND	Pin 22	XX
Pin 3	EDP_TXN3	Pin 23	GND
Pin 4	EDP_TXP3	Pin 24	GND
Pin 5	GND	Pin 25	GND
Pin 6	EDP_TXN2	Pin 26	GND
Pin 7	EDP_TXP2	Pin 27	EDP_HPDP
Pin 8	GND	Pin 28	GND
Pin 9	EDP_TXN1	Pin 29	GND
Pin 10	EDP_TXP1	Pin 30	GND
Pin 11	GND	Pin 31	EDP_DETECT
Pin 12	EDP_TXN0	Pin 32	EDP_Backlight Enable
Pin 13	EDP_TXP0	Pin 33	EDP_Backlight PWM
Pin 14	GND	Pin 34	XX
Pin 15	EDP_AUXP	Pin 35	XX
Pin 16	EDP_AUXN	Pin 36	Backlight power
Pin 17	GND	Pin 37	Backlight power
Pin 18	LCD_VCC	Pin 38	Backlight power
Pin 19	LCD_VCC	Pin 39	Backlight power
Pin 20	LCD_VCC	Pin 40	XX

***Note:** Pin18/19/20 please follow the setting of JP3

(12) LVDS (30-pin): 24-bit dual channel LVDS Header (2.0 pitch)

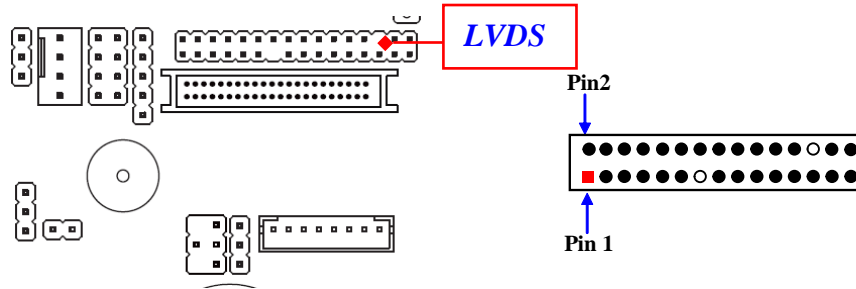

Pin NO.	Pin Define	Pin NO.	Pin Define
Pin 1	E-DATAN3	Pin 2	E-DATAP3
Pin 3	E-CLKN	Pin 4	E-CLKP
Pin 5	E-DATAN2	Pin 6	E-DATAP2
Pin 7	E-DATAN1	Pin 8	E-DATAP1
Pin 9	E-DATAN0	Pin 10	E-DATAP0
Pin 11	DDC_SDA	Pin 12	DDC_SCL
Pin 13	XX	Pin 14	GND
Pin 15	GND	Pin 16	GND
Pin 17	O-DATAP3	Pin 18	O-DATAN3
Pin 19	O-CLKP	Pin 20	O-CLKN
Pin 21	O-DATAP2	Pin 22	O-DATAN2
Pin 23	O-DATAP1	Pin 24	O-DATAN1
Pin 25	O-DATAP0	Pin 26	O-DATAN0
Pin 27	LCD_VCC	Pin 28	XX
Pin 29	LCD_VCC	Pin 30	LCD_VCC
Pin 31	GND	Pin 32	GND

***Note:** User can choose between LVDS and EDP display options, but **only one of them can function at the same time**. Before connecting compatible cable to corresponding header/wafer, user should go to BIOS settings→**Chipset**→**Uncore Configuration**→**Active LFP**, and set it as [LVDS] or [EDP] based on actual configuration.

Chapter 3

Introducing BIOS

Notice! The BIOS options in this manual are for reference only. Different configurations may lead to difference in BIOS screen and BIOS screens in manuals are usually the first BIOS version when the board is released and may be different from your purchased motherboard. Users are welcome to download the latest BIOS version form our official website.

The BIOS is a program located on a Flash Memory on the motherboard. This program is a bridge between motherboard and operating system. When you start the computer, the BIOS program will gain control. The BIOS first operates an auto-diagnostic test called POST (power on self test) for all the necessary hardware, it detects the entire hardware device and configures the parameters of the hardware synchronization. Only when these tasks are completed done it gives up control of the computer to operating system (OS). Since the BIOS is the only channel for hardware and software to communicate, it is the key factor for system stability, and in ensuring that your system performance as its best.

3-1 Entering Setup

Power on the computer and by pressing immediately allows you to enter Setup. If the message disappears before your respond and you still wish to enter Setup, restart the system to try again by turning it OFF then ON or pressing the “RESET” button on the system case. You may also restart by simultaneously pressing <Ctrl>, <Alt> and <Delete> keys. If you do not press the keys at the correct time and the system does not boot, an error message will be displayed and you will again be asked to

Press to enter Setup/ Press <F7> to enter Popup Menu.

```

Please select boot device:

Windows Boot Manager (MMC - BJTD4R)
MMC - BJTD4R
UEFI: Built-in EFI Shell
Enter Setup

↑ and ↓ to move selection
ENTER to select boot device
ESC to boot using defaults

```

3-2 BIOS Menu Screen

The following diagram show a general BIOS menu screen:

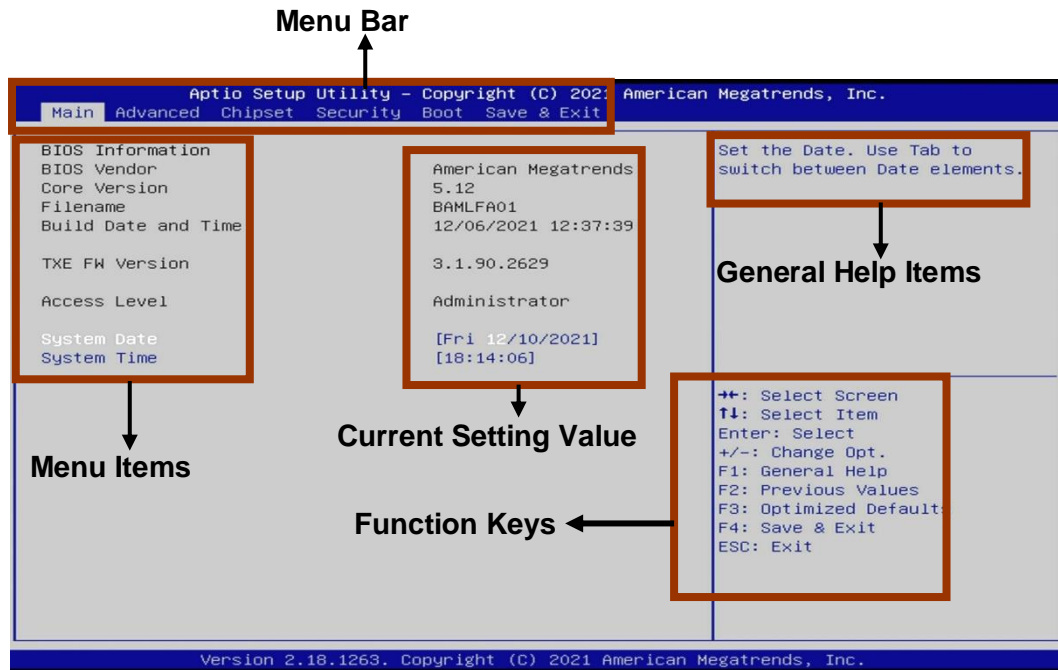

3-3 Function Keys

In the above BIOS Setup main menu of, you can see several options. We will explain these options step by step in the following pages of this chapter, but let us first see a short description of the function keys you may use here:

- Press ←→ (left, right) to select screen;
- Press ↑↓ (up, down) to choose, in the main menu, the option you want to confirm or to modify.
- Press <Enter> to select.
- Press <+>/<-> keys when you want to modify the BIOS parameters for the active option.
- [F1]: General help.
- [F2]: Previous value.
- [F3]: Optimized defaults.
- [F4]: Save & Exit.
- Press <Esc> to quit the BIOS Setup.

3-4 Getting Help

Main Menu

The on-line description of the highlighted setup function is displayed at the top right corner the screen.

Status Page Setup Menu/Option Page Setup Menu

Press [F1] to pop up a small help window that describes the appropriate keys to use and the possible selections for the highlighted item. To exit the Help Window, press <Esc>.

3-5 Menu Bars

There are six menu bars on top of BIOS screen:

Main	To change system basic configuration
Advanced	To change system advanced configuration
Chipset	To change chipset configuration
Security	Password settings
Boot	To change boot settings
Save & Exit	Save setting, loading and exit options.

User can press the right or left arrow key on the keyboard to switch from menu bar. The selected one is highlighted.

3-6 Main Menu

Main menu screen includes some basic system information. Highlight the item and then use the <+> or <-> and numerical keyboard keys to select the value you want in each item.

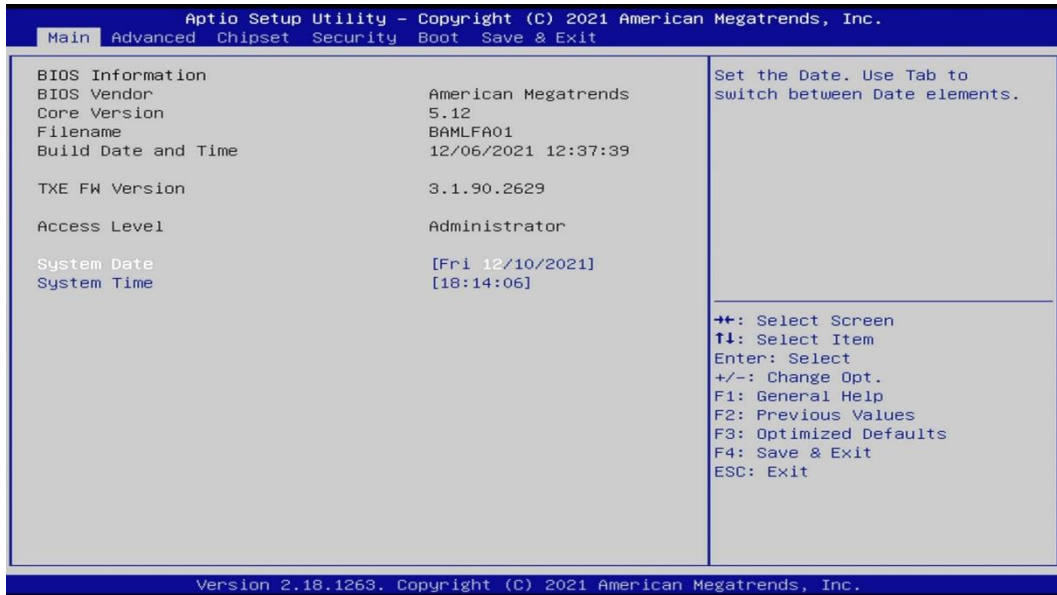

System Date

Set the date. Please use [Tab] to switch between date elements.

System Time

Set the time. Please use [Tab] to switch between time elements.

3-7 Advanced Menu

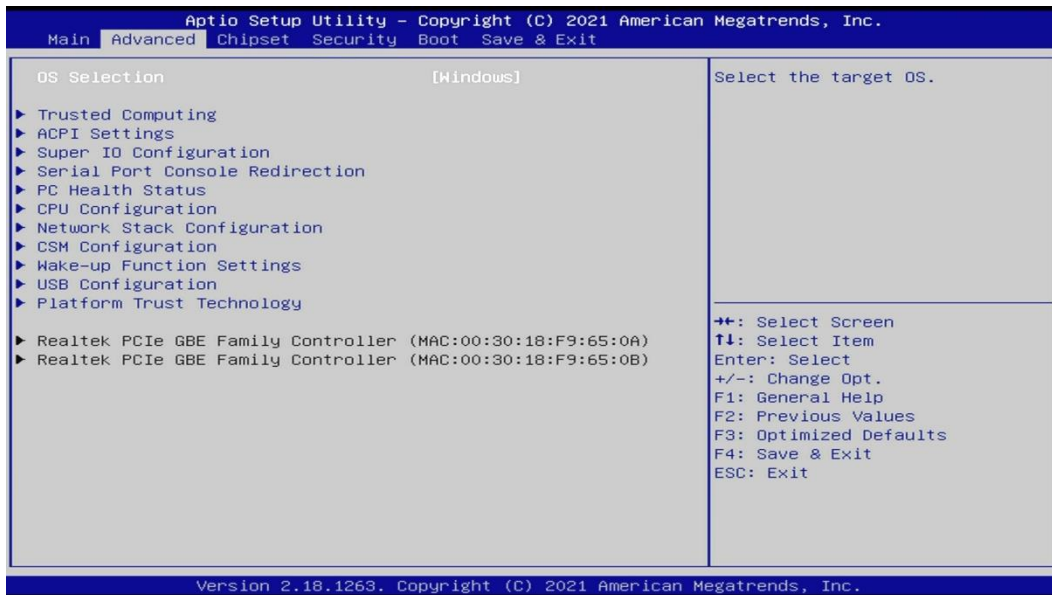

OS Selection

The optional settings: [Windows]; [Intel Linux]; [MSDOS].

***Note:** User need to go to this item to select the OS mode before installing corresponding OS driver, otherwise problems will occur when installing the driver.

▶ Trusted Computing

Press [Enter] to enable or disable 'Security Device Support'.

Configuration

Security Device Support

Use this item to enable or disable BIOS support for security device. O.S will not show Security Device. TCG EFI protocol and INT1A interface will not be available.

The optional settings: [Disabled]; [Enabled].

When set as **[Enabled]**, user can make further settings in the following items:

SHA-1 PCR Bank

Use this item to enable or disable SHA-1 PCR Bank.

The optional settings: [Disabled]; [Enabled].

SHA256 PCR Bank

Use this item to enable or disable SHA256 PCR Bank.

The optional settings: [Disabled]; [Enabled].

Pending Operation

Use this item to set an Operation for the Security Device..

The optional settings: [None]; [TPM Clear].

**Note: Your Computer will reboot during restart in order to change state of security device.*

▶ **ACPI Settings**

Press [Enter] to make settings for the following sub-items:

ACPI Settings

ACPI Sleep State

Use this item to select the highest ACPI sleep state the system will enter when the suspend button is pressed.

The optional settings are: [Suspend Disabled]; [S3 (Suspend to RAM)].

▶ **Super I/O Configuration**

Press [Enter] to make settings for the following sub-items:

Super I/O Configuration

▶ **Serial Port 1 Configuration**

Press [Enter] to make settings for the following items:

Serial Port 1 Configuration

Serial Port

Use this item to enable or disable serial port 1 (COMA).

The optional settings are: [Disabled]; [Enabled].

When set as **[Enabled]**, user can make further settings in the following items:

Change Settings

Use this item to select an optimal setting for super IO device.

The optional settings are: [Auto]; [IO=3F8h; IRQ=4]; [IO=2F8h; IRQ=3]; [IO=3E8h; IRQ=4]; [IO=2E8h; IRQ=3].

▶ **Serial Port 2 Configuration**

Press [Enter] to make settings for the following items:

Serial Port 2 Configuration

Serial Port

Use this item to enable or disable serial port 2 (COMB).

The optional settings are: [Disabled]; [Enabled].

When set as **[Enabled]**, user can make further settings in the following items:

Change Settings

Use this item to select an optimal setting for Super IO Device.

The optional settings are: [Auto]; [IO=3F8h; IRQ=4]; [IO=2F8h; IRQ=3]; [IO=3E8h; IRQ=4]; [IO=2E8h; IRQ=3].

ERP Support

Use this item to enable or disable Energy-Related Products function.

The optional settings: [Disabled]; [Enabled].

This item should be set as **[Disabled]** if you wish to have all active wake-up functions.

Case Open Detect

Use this item to detect case has already open or not, show message in POST.

The optional settings: [Disabled]; [Enabled].

When set as [Enabled], system will detect if *pin 1-2 of jumper JP2* has been short or not (refer to **Page 12**; if *pin 1-2 of jumper JP2* is short, system will show Case Open Message during POST.

WatchDog Reset Timer

Use this item to enable or disable WDT reset function.

The optional settings: [Disabled]; [Enabled].

When set as [Enabled], the following sub-items shall appear:

WatchDog Reset Timer Value

User can select a value in the range of [10] to [255] seconds when '**WatchDog Reset Timer Unit**' set as [Sec]; or in the range of [1] to [255] minutes when '**WatchDog Reset Timer Unit**' set as [Min].

WatchDog Reset Timer Unit

The optional settings are: [Sec.]; [Min.].

WatchDog Wake-up Timer

This item support WDT wake-up.

The optional settings are: [Enabled]; [Disabled].

When set as [Enabled], the following sub-items shall appear:

WatchDog Wake-up Timer Value

User can select a value in the range of [10] to [4095] seconds when 'WatchDog Wake-up Timer Unit' set as [Sec]; or in the range of [1] to [4095] minutes when 'WatchDog Wake-up Timer Unit' set as [Min].

WatchDog Wake-up Timer Unit

The optional settings are: [Sec.]; [Min.].

ATX Power Emulate AT Power

This item support Emulate AT power function, MB power On/Off control by power supply. Use needs to select 'AT or ATX Mode' on MB jumper at first (refer to **Page 10**, jumper ATX_AT pin 1-2 for ATX Mode & pin 2-3 for AT Mode Select).

▶ **Serial Port Console Redirection**

COM1

Console Redirection

Use this item to enable or disable Console Redirection.

The optional settings: [Disabled]; [Enabled].

When set as [**Enabled**], the following sub-items shall appear:

▶ **Console Redirection Settings**

The settings specify how the host computer and the remote computer (which the user is using) will exchange data. Both computers should have the same or compatible settings.

Press [Enter] to make settings for the following items:

Terminal Type

The optional settings: [VT100]; [VT100+]; [VT-UTF8]; [ANSI].

Emulation: [ANSI]: Extended ASCII char set; [VT100]: ASCII char set; [VT100+]:

Extends VT100 to support color, function keys, etc.; [VT-UTF8]: Uses UTF8 encoding to map Unicode chars onto 1 or more bytes.

Bits per second

Use this item to select serial port transmission speed. The speed must be matched on the other side. Long or noisy lines may require lower speeds.

The optional settings: [9600]; [19200]; [38400]; [57600]; [115200].

Data Bits

The optional settings: [7]; [8].

Parity

A parity bit can be sent with the data bits to detect some transmission errors.

The optional settings: [None]; [Even]; [Odd]; [Mark]; [Space].

[Even]: parity bit is 0 if the num of 1's in the data bits is even; [Odd]: parity bit is 0 if num of 1's in the data bits is odd; [Mark]: parity bit is always 1; [Space]: Parity bit is always 0; [Mark] and [Space] Parity do not allow for error detection.

Stop Bits

Stop bits indicate the end of a serial data packet. (A start bit indicates the beginning).

The standard setting is 1 stop bit. Communication with slow devices may require more than 1 stop bit.

The optional settings: [1]; [2].

Flow Control

Flow control can prevent data loss from buffer overflow. When sending data, if the receiving buffers are full, a “stop” signal can be sent to stop the data flow. Once the buffers are empty, a “start” signal can be sent to re-start the flow. Hardware flow control uses two wires to send start/stop signals.

The optional settings: [None]; [Hardware RTS/CTS].

VT-UTF8 Combo Key Support

Use this item to enable VT-UTF8 Combination Key Support for ANSI/VT100 terminals.

The optional settings: [Disabled]; [Enabled].

Recorder Mode

With this mode enable only text will be sent. This is to capture Terminal data.

The optional settings: [Disabled]; [Enabled].

Resolution 100x31

Use this item to enable or disable extended terminal resolution.

The optional settings: [Disabled]; [Enabled].

Legacy OS Redirection Resolution

On Legacy OS, the Number of Rows and Columns supported redirection.

The optional settings: [80x24]; [80x25].

Putty KeyPad

Use this item to select FunctionKey and KeyPad on Putty.

The optional settings: [VT100]; [Intel Linux]; [XTERMR6]; [SCO]; [ESCN]; [VT400].

Redirection After BIOS POST

The optional settings are: [Always Enable]; [BootLoader].

When [Bootloader] is selected, then Legacy Console Redirection is disabled before booting to legacy OS. When [Always Enable] is selected, then Legacy Console is enabled for legacy OS. Default setting for this option is set to [Always Enable].

Serial Port for Out-of-Band Management/ Windows Emergency Management Services (EMS)

Console Redirection

Use this item to enable or disable Console Redirection.

The optional settings: [Disabled]; [Enabled].

When set as **[Enabled]**, the following sub-items shall appear:

▶ **Console Redirection Settings**

The settings specify how the host computer and the remote computer (which the user is using) will exchange data. Both computers should have the same or compatible settings.

Press [Enter] to make settings for the following items:

Out-of-Band Mgmt Port

The default setting is: [COM1].

Terminal Type

The optional settings: [VT100]; [VT100+]; [VT-UTF8]; [ANSI].

[VT-UTF8] is the preferred terminal type for out-of-band management. The next best choice is [VT100+] and then [VT100]. See above, in Console Redirection Settings page, for more help with Terminal Type/Emulation.

Bits per second

Use this item to select serial port transmission speed. The speed must be matched on the other side. Long or noisy lines may require lower speeds.

The optional settings: [9600]; [19200]; [57600]; [115200].

Flow Control

Flow control can prevent data loss from buffer overflow. When sending data, if the receiving buffers are full, a “stop” signal can be sent to stop the data flow. Once the buffers are empty, a “start” signal can be sent to re-start the flow. Hardware flow control uses two wires to send start/stop signals.

The optional settings: [None]; [Hardware RTS/CTS]; [Software Xon/Xoff].

Data Bits

The default setting is: [8].

**This item may or may not show up, depending on different configuration.*

Parity

The default setting is: [None].

**This item may or may not show up, depending on different configuration.*

Stop Bits

The default setting is: [1].

**This item may or may not show up, depending on different configuration.*

► **PC Health Status**

Press [Enter] to view current hardware health status, make further settings in '**SmartFAN Configuration**'.

► **SmartFAN Configuration**

Press [Enter] to make settings for SmartFan Configuration:

SmartFAN Configuration

CPUFAN Type/SYSFAN Type

The optional settings are: [4-Pin]; [3-Pin].

CPUFAN /SYSFAN Smart Mode

The optional settings are: [Disabled]; [Enabled].

When set as **[Enabled], user can make further settings in the following sub-items:*

CPUFAN/SYSFAN Full-Speed Temperature

Use this item to set CPUFAN/SYSFAN full speed temperature. Fan will run at full speed when above this pre-set temperature.

CPUFAN/SYSFAN Full-Speed Duty

Use this item to set CPUFAN/SYSFAN full-speed duty. Fan will run at full speed when above this pre-set duty.

CPUFAN/SYSFAN Idle-Speed Temperature

Use this item to set CPUFAN/SYSFAN idle speed temperature. Fan will run at idle speed when below this pre-set temperature.

CPUFAN/SYSFAN Idle-Speed Duty

Use this item to set CPUFAN/SYSFAN idle speed duty. Fan will run at idle speed when below this pre-set duty.

▶ **CPU Configuration**

Press [Enter] to view current CPU configuration and make settings for the following sub-items:

VT-d

Use this item to enable or disable CPU VT-d.

The optional settings: [Enabled]; [Disabled].

EIST

Use this item to enable or disable Intel SpeedStep.

The optional settings: [Disabled]; [Enabled].

When set as **[Enabled]**, the following sub-items shall appear:

Turbo Mode

Use this item to enable or disable Turbo Mode.

The optional settings: [Disabled]; [Enabled].

C-States

Use this item to enable or disable C-State.

The optional settings: [Disabled]; [Enabled].

When set as **[Enabled]**, users can make more settings in the following sub-items:

Enhanced C-states

Use this item to enable or disable C1E. When enabled, CPU will switch to minimum speed when all cores enter C-state.

The optional settings: [Disabled]; [Enabled].

Max Package C State

Use this item to control the Max Package C State that the processor will support.

The optional settings: [PC2]; [PC1]; [C0].

Max Core C State Limit

This item controls the max Core C State that cores will support.

The optional settings: [Fused Value]; [Core C10]; [Core C9] [Core C8]; [Core C 7]; [Core C 6]; [Core C1]; [Unlimited].

▶ **Network Stack Configuration**

Press [Enter] to go to '**Network Stack**' screen to make further settings.

Network Stack

The optional settings are: [Enabled]; [Disabled].

When set as [Enabled], the following sub-items shall appear:

Ipv4 PXE Support

The optional settings are: [Disabled]; [Enabled].

Use this item to enable Ipv4 PXE Boot Support. When set as [Disabled], Ipv4 boot option will not be created.

Ipv6 PXE Support

The optional settings are: [Disabled]; [Enabled].

Use this item to enable Ipv6 PXE Boot Support. When set as [Disabled], Ipv6 boot option will not be created.

PXE Boot Wait Time

Use this item to set wait time to press [ESC] key to abort the PXE boot.

Media Detect Count

Use this item to set number of times presence of media will be checked.

The optional settings range is from [1] to [50].

▶ **CSM Configuration**

Press [Enter] to make settings for the following sub-items:

Compatibility Support Module Configuraton

Boot option filter

This item controls Legacy/UEFI ROMs priority.

The optional settings are: [UEFI and Legacy]; [Legacy only]; [UEFI only].

Network

This item controls the execution of UEFI and Legacy PXE OpROM.

The optional settings are: [Do not launch]; [UEFI]; [Legacy].

Storage

This item controls the execution of UEFI and Legacy Storage OpROM.

The optional settings are: [Do not launch]; [UEFI]; [Legacy].

Video

This item controls the execution of UEFI and Legacy Video OpROM.

The optional settings are: [UEFI]; [Legacy].

Other PCI devices

This item determines OpROM execution policy for devices other than Network, storage or video.

The optional settings are: [Do not launch]; [UEFI]; [Legacy].

▶ **Wake-up Function Settings**

Press [Enter] to make settings for the following sub-items:

Wake-up System With Fixed Time

Use this item to enable or disable System wake on alarm event.

The optional settings: [Disabled]; [Enabled].

When set as **[Enabled]**, the following items shall appear:

Wake-up Hour

Use this item to select 0-23. For example enter 3 for 3am and 15 for 3pm.

Wake-up Minute

Use this item to select 0-59.

Wake-up Second

Use this item to select 0-59.

Wake-up System with Dynamic Time

Use this item to enable or disable System wake on alarm event.

System will wake on the current time + Increase minute(s).

The optional settings: [Disabled]; [Enabled].

When set as **[Enabled]**, system will wake on the current time + increased minute(s).

USB/PS2 Power Gating in S4-S5

Use this item to enable or disable USB/PS2 wake-up from S4-S5.

USB Wake-up is affected by ERP function in S4. Please disable ERP before activating this function in S4.

The optional settings: [Disabled]; [Enabled].

**Note: This function is supported when 'ERP Support' is set as [Disabled].*

▶ **USB Configuration**

Press [Enter] to make settings for the following sub-items:

USB Configuration

Legacy USB Support

Use this item to enable or disable Legacy USB support.

The optional settings are: [Enabled]; [Disabled]; [Auto].

[Enabled]: To enable legacy USB support.

[Disabled]: To keep USB devices available only for EFI specification,

[Auto]: To disable legacy support if no USB devices are connected.

XHCI Hand-off

This is a workaround for Oses without XHCI hand-off support. The XHCI ownership change should be claimed by XHCI driver.

The optional settings are: [Enabled]; [Disabled].

USB Mass Storage Driver Support

Use this item to enable or disable USB Mass Storage Driver Support.

The optional settings are: [Disabled]; [Enabled].

USB Hardware Delays and Time-outs:

USB Transfer Time-out

Use this item to set the time-out value for control, bulk, and interrupt transfers.

The optional settings are: [1 sec]; [5 sec]; [10 sec]; [20 sec].

Device Reset Time-out

Use this item to set USB mass storage device start unit command time-out.

The optional settings are: [10 sec]; [20 sec]; [30 sec]; [40 sec].

Device Power-up Delay

Use this item to set maximum time the device will take before it properly reports itself to the host controller.

The optional settings: [Auto]; [Manual].

'Auto' uses default value: for a root port it is 100 ms, for a hub port the delay is taken from hub descriptor.

Select [Manual] you can set value for the following sub-item: '**Device Power-up Delay in Seconds**'.

Device Power-up Delay in Seconds

The delay range is from [1] to [40] seconds, in one second increments.

▶ **Platform Trust Technology**

Press [Enter] to make settings for the following sub-items:

TPM Configuration

fTPM

Use this item to enable or disable fTPM.

The optional settings: [Enabled]; [Disabled].

▶ **Realtek PCIe GBE Family Controller(MAC:XX:XX:XX:XX:XX:XX)**

These items show current network brief information.

***Note:** *The secondary Realtek PCIe GBE Family Controller shows up based on actual configuration of the actual product.*

3-8 Chipset Menu

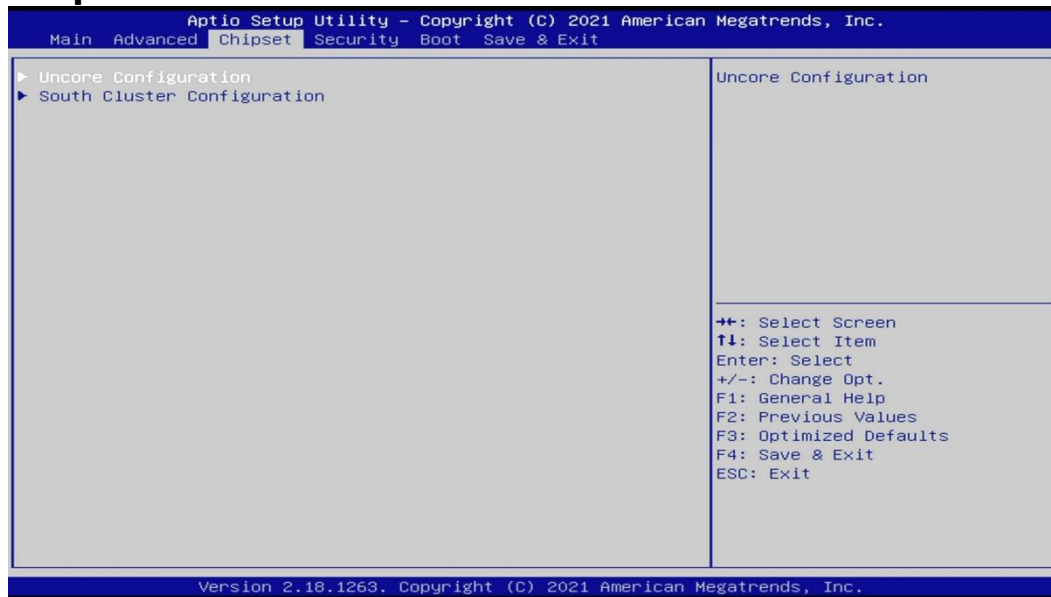

► **Uncore Configuration**

Press [Enter] to make settings for the following sub-items:

GTT Size

The optional settings are: [2MB]; [4MB]; [8MB].

DVMT Pre-Allocated

Use this item to select DVMT 5.0 pre-allocated (fixed) graphics memory size used by the internal graphics device.

The optional settings are: [64M]; [96M]; [128M]; [160M]; [192M]; [224M]; [256M]; [288M]; [320M]; [352M]; [384M]; [416M]; [448M]; [480M]; [512M].

DVMT Total Gfx Memory

Use this item to select DVMT 5.0 total graphics memory size used by the internal graphics device.

The optional settings are: [128M]; [256M]; [MAX].

Active LFP

The optional settings are: [Disabled]; [LVDS]; [eDP].

* *When set as [LVDS], user can make further setting in the following sub-items:*

LCD Panel Type

Use this item to select LCD panel used by Internal Graphics Device by selecting the appropriate setup item.

The optional settings are: [800x480 1-ch 18-bit]; [800x600 1-ch 18-bit]; [800x600 1-ch 24-bit]; [1024x600 1-ch 18-bit]; [1024x768 1-ch 18-bit]; [1024x768 1-ch 24-bit]; [1280x768 1-ch 24-bit]; [1280x800 1-ch 18-bit]; [1280x800 1-ch 24-bit]; [1366x768 1-ch 18-bit]; [1366x768 1-ch 24-bit]; [1440x900 2-ch 18-bit]; [1440x900 2-ch 24-bit]; [1280x1024 2-ch 24-bit]; [1680x1050 2-ch 24-bit]; [1920x1080 2-ch 24-bit].

LVDS FW Protect

Use this item to select LCD panel used by Internal Graphics Device by selecting the appropriate setup item.

The optional settings are: [Enabled]; [Disabled].

* *When set as [LVDS] or [eDP], user can make further setting in the following sub-items:*

GMCH BLC Control

Use this item to select back light control setting.

The optional settings are: [PWM-Inverted]; [PWM-Normal].

Primary IGFX Boot Display

Use this item to select the video device which will be activated during POST.

The optional settings are: [Auto]; [LFP]; [HDMI1]; [HDMI2].

Secondary IGFX Boot Display

Use this item to select Secondary Display Device.

The optional settings are: [Disabled]; [HDMI1]; [HDMI2].

Memory Information

The working memory information will be on display.

▶ **South Cluster Configuration**

▶ **PCI Express Configuration**

Press [Enter] to make settings for the following sub-items:

PCI Express Configuration

Peer Memory Write Enable

The optional settings: [Disabled]; [Enabled].

Compliance Mode

The optional settings: [Disabled]; [Enabled].

Onboard PCIE LAN

The optional settings: [Disabled]; [Enabled].

▶ **SATA Configuration**

Press [Enter] to make settings for the following sub-items:

SATA Controller

Use this item to enable or disable the Chipset SATA Controller. The Chipset SATA controller supports the 2 blank internal SATA ports (up to 3Gb/s supported per port). The optional settings are: [Enabled]; [Disabled].

When set as **[Enabled]**, user can make further settings in the following sub-items:

SATA Mode Selection

Use this item to determine how SATA controller(s) operate.

The default setting is: [AHCI].

SATA Port

SATA Port

Use this item to enable or disable SATA port.

The optional settings: [Disabled]; [Enabled].

M.2

M.2

Use this item to enable or disable SATA port.

The optional settings: [Disabled]; [Enabled].

HD-Audio Support

Use this item to enable or disable HD-Audio Support.

The optional settings are: [Disabled]; [Enabled].

SCC eMMC Support

Use this item to enable or disable SCC eMMC Support.

The optional settings are: [Disabled]; [Enabled].

eMMC Max Speed

Use this item to select the eMMC max Speed allowed.

The optional settings are: [HS400]; [HS200]; [DDR50].

System State after Power Failure

Use this item to specify what state to go to when power re-applied after a power failure (G3 state).

The optional settings are: [Always On]; [Always Off]; [Former State].

3-9 Security Menu

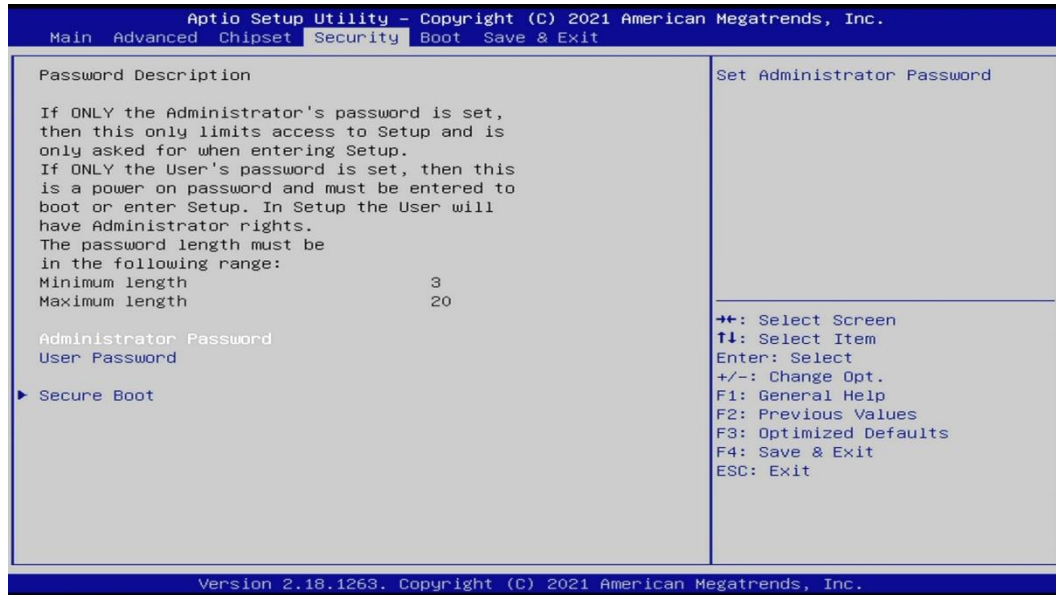

Security menu allow users to change administrator password and user password settings.

Administrator Password

If there is no password present on system, please press [Enter] to create new administrator password. If password is present on system, please press [Enter] to verify old password then to clear/change password. Press again to confirm the new administrator password.

User Password

If there is no password present on system, please press [Enter] to create new administrator password. If password is present on system, please press [Enter] to verify old password then to clear/change password. Press again to confirm the new administrator password.

▶ Secure Boot

Press [Enter] to make customized secure settings:

Secure Boot Control

Secure Boot can be enabled if 1. System running in user mode with enrolled Platform Key (PK); 2. CSM function is disabled.

The optional settings are: [Disabled]; [Enabled].

Secure Boot Mode

Set UEFI Secure Boot Mode to Standard mode or Custom mode. This change is effective after save. After reset, this mode will return to Standard mode.

The optional settings are: [Standard]; [Custom].

**When set as [Custom], user can make further settings in 'Key Management'.*

▶ Key Management

This item enables experienced users to modify Secure Boot variables, which includes the following items:

Provision Factory Default Keys

This item is for user to install factory default secure boot keys when system is in Setup Mode.

The optional settings are: [Disabled]; [Enabled].

▶ Enroll All Factory Default Keys

This item forces system to User Mode-install all Factory Default keys.

**This item shows up when 'Provision Factory Default Keys' is set as [Enabled].*

▶ Save all Secure Boot Variables

This item will save NVRAM content of all Secure Boot variables to the files (WFI_SIGNATURE_LIST data format) in root folder on a target file system device.

▶ Platform Key (PK)/Key Exchange Keys/Authorized Signature/Forbidden Signature/ Authorized TimeStamps/OS Recovery Signatures

Use this item to enroll Factory Defaults or load the keys from a file with:

1. Public Key Certificate in:

- a) EFI_SIGNATURE_LIST
- b) EFI_CERT_X509 (DER encoded)
- c) EFI_CERT_RSA2048 (bin)
- d) EFI_CERT_SHA256 (bin)

2. Authenticated UEFI Variable

3-10 Boot Menu

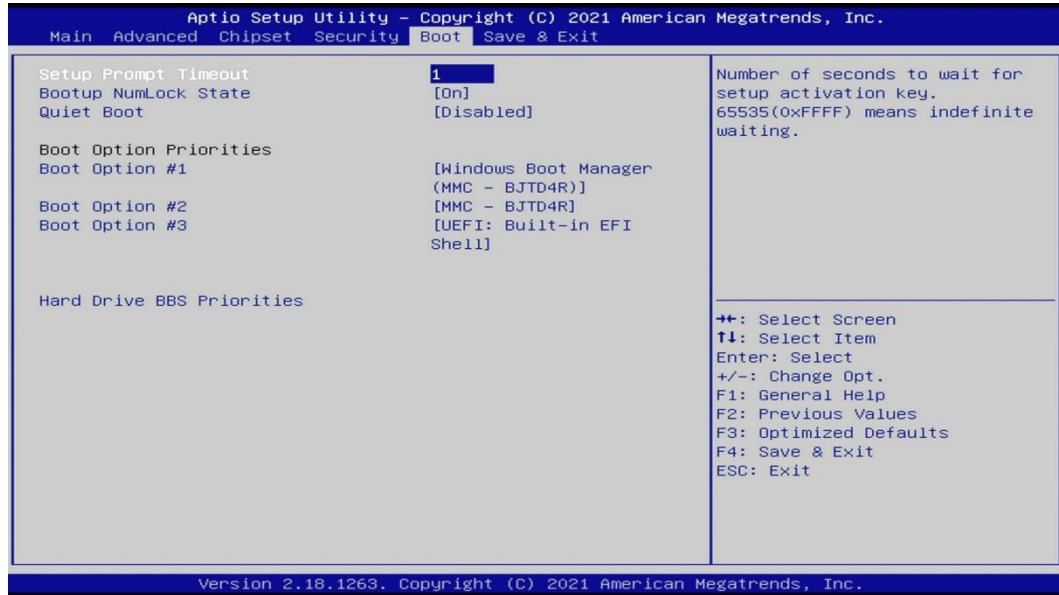

Setup Prompt Timeout

Use this item to set number of seconds to wait for setup activation key.

Bootup NumLock State

Use this item to select keyboard numlock state.

The optional settings are: [On]; [Off].

Quiet Boot

The optional settings are: [Disabled]; [Enabled].

Boot Option Priorities

Boot Option #1/ Boot Option #2/ Boot Option #3

Use this item to set the system boot order.

The optional settings are: [Windows Boot Manager (MMC-BJTD4R)]; [MMC- BJTD4R]; [UEFI: Built-in EFI Shell]; [Disabled].

Hard Drive BBS Priorities

Use this to set the order of the legacy devices in this group. Press [Enter] to make setting for the following item:

Boot Option #1

Use this item to set the system boot order.

The optional settings are: [MMC-BJTD4R]; [Disabled].

3-11 Save & Exit Menu

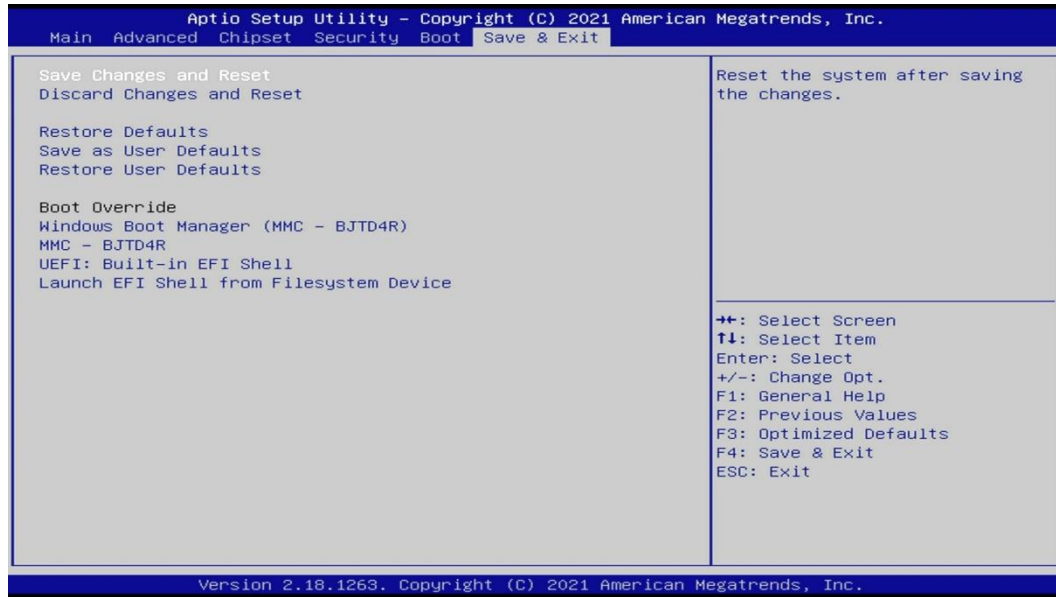

Save Changes and Reset

This item allows user to reset the system after saving the changes.

Discard Changes and Reset

This item allows user to reset the system without saving any changes.

Restore Defaults

Use this item to restore /load default values for all the setup options.

Save as User Defaults

Use this item to save the changes done so far as user defaults.

Restore User Defaults

Use this item to restore defaults to all the setup options.

Boot Override

The available options here are dynamically updated and make system boot to any boot option selected.

Windows Boot Manager (MMC-BJTD4R)

MMC-BJTD4R

UEFI: Built-in EFI Shell

Launch EFI Shell from filesystem device

Use this item to launch EFI shell application (shell.efi) from one of the available filesystem device.