

Technical Manual
Of
Intel Bay Trail Series CPU
Based Mini-ITX M/B

NO. G03-MI97-F

Revision: 2.0

Release date: January 25, 2022

Trademark:

- * Specifications and Information contained in this documentation are furnished for information use only, and are subject to change at any time without notice, and should not be construed as a commitment by manufacturer.

Environmental Protection Announcement

Do not dispose this electronic device into the trash while discarding. To minimize pollution and ensure environment protection of mother earth, please recycle.



TABLE OF CONTENT

ENVIRONMENTAL SAFETY INSTRUCTION.....	iii
USER'S NOTICE	iv
MANUAL REVISION INFORMATION	iv
ITEM CHECKLIST	iv
CHAPTER 1 INTRODUCTION OF THE MOTHERBOARD	
1-1 FEATURE OF MOTHERBOARD	1
1-2 SPECIFICATION	2
1-3 LAYOUT DIAGRAM	3
CHAPTER 2 HARDWARE INSTALLATION	
2-1 JUMPER SETTING.....	8
2-2 CONNECTORS AND HEADERS	18
2-2-1 CONNECTORS	18
2-2-2 HEADERS	23
CHAPTER 3 INTRODUCING BIOS	
3-1 ENTERING SETUP.....	30
3-2 BIOS MENU SCREEN.....	31
3-3 FUNCTION KEYS.....	31
3-4 GETTING HELP.....	32
3-5 MENU BARS	32
3-6 MAIN MENU	33
3-7 ADVANCED MENU	34
3-8 CHIPSET MENU	46
3-9 SECURITY MENU	49
3-10 BOOT MENU	50
3-11 SAVE & EXIT MENU	51



Environmental Safety Instruction

- Avoid the dusty, humidity and temperature extremes. Do not place the product in any area where it may become wet.
- 0 to 40 centigrade is the suitable temperature. (The temperature comes from the request of the chassis and thermal solution)
- Generally speaking, dramatic changes in temperature may lead to contact malfunction and crackles due to constant thermal expansion and contraction from the welding spots' that connect components and PCB. Computer should go through an adaptive phase before it boots when it is moved from a cold environment to a warmer one to avoid condensation phenomenon. These water drops attached on PCB or the surface of the components can bring about phenomena as minor as computer instability resulted from corrosion and oxidation from components and PCB or as major as short circuit that can burn the components. Suggest starting the computer until the temperature goes up.
- The increasing temperature of the capacitor may decrease the life of computer. Using the close case may decrease the life of other device because the higher temperature in the inner of the case.
- Attention to the heat sink when you over-clocking. The higher temperature may decrease the life of the device and burned the capacitor.

USER'S NOTICE

COPYRIGHT OF THIS MANUAL BELONGS TO THE MANUFACTURER. NO PART OF THIS MANUAL, INCLUDING THE PRODUCTS AND SOFTWARE DESCRIBED IN IT MAY BE REPRODUCED, TRANSMITTED OR TRANSLATED INTO ANY LANGUAGE IN ANY FORM OR BY ANY MEANS WITHOUT WRITTEN PERMISSION OF THE MANUFACTURER.

THIS MANUAL CONTAINS ALL INFORMATION REQUIRED TO USE THIS MOTHER-BOARD SERIES AND WE DO ASSURE THIS MANUAL MEETS USER'S REQUIREMENT BUT WILL CHANGE, CORRECT ANY TIME WITHOUT NOTICE. MANUFACTURER PROVIDES THIS MANUAL "AS IS" WITHOUT WARRANTY OF ANY KIND, AND WILL NOT BE LIABLE FOR ANY INDIRECT, SPECIAL, INCIDENTAL OR CONSEQUENTIAL DAMAGES (INCLUDING DAMAGES FOR LOSS OF PROFIT, LOSS OF BUSINESS, LOSS OF USE OF DATA, INTERRUPTION OF BUSINESS AND THE LIKE).

PRODUCTS AND CORPORATE NAMES APPEARING IN THIS MANUAL MAY OR MAY NOT BE REGISTERED TRADEMARKS OR COPYRIGHTS OF THEIR RESPECTIVE COMPANIES, AND THEY ARE USED ONLY FOR IDENTIFICATION OR EXPLANATION AND TO THE OWNER'S BENEFIT, WITHOUT INTENT TO INFRINGE.

Manual Revision Information

Reversion	Revision History	Date
2.0	Second Edition	January 25, 2022

Item Checklist

- Motherboard
- Cable(s)

Chapter 1

Introduction of the Motherboard

1-1 Feature of Motherboard

- Onboard Intel® Bay Trail Series Processor, with low power consumption never denies high performance
- Support 1* DDR3L 1333 MHz SO-DIMM, up to 8GB
- 1* SATA II (3Gb/s) & M.2 M-key 2242/2280 slot (SATA interface)
- 1*M.2 E key 2230 slot (PCIe x1/USB 2.0 interface)
- 1*M.2 B key 3042 slot (USB 2.0 interface) with SIM card holder to support 3G/4G Module
- 1* PCI-E x1 slot
- Amplifier implement to support 3W Speaker
- Support 5*RS232 (**COM1** supports RS232/422/485)
- Support up to 7* USB 2.0 + 1* USB 3.0
- Intel® HD Graphics integration supports 1* VGA, 1* HDMI & 1* LVDS/1*eDP (eDP co-lay with LVDS)
- Support 12V DC-in power
- Support TPM 2.0 (**MI97-32 series**)
- Support CPU Smart FAN
- Supports ACPI S3 Function
- Compliance with ErP standard
- Support Watchdog function

1-2 Specification

Spec	Description
Design	<ul style="list-style-type: none"> ● Mini-ITX form factor; PCB size: 17.0x17.0cm
Embedded CPU	<ul style="list-style-type: none"> ● Integrated with Intel® Bay Trail series CPU <p><i>*Note: for detailed CPU support information please visit our website</i></p>
Memory Slot	<ul style="list-style-type: none"> ● *DDR3L SO-DIMM slot ● Support DDR3L 1333MHz SO-DIMM up to 8GB
Expansion	<ul style="list-style-type: none"> ● 1* PCIe x1 slot (PCI-E) ● 1* M.2 M Key slot (M2M, type-2242/2280, SATA interface) ● 1* M.2 E Key slot (M2E, type-2230, USB 2.0 & PCIe x1 interface) ● 1* M.2 B Key slot (M2B, type-3042, USB 2.0 interface) ● 1* SIM Card holder (SIMCARD) <p><i>*Note: SIM card is supported when M2B (M.2 B-Key 3042) slot is installed with 3G/4G/LTE card.</i></p>
Storage	<ul style="list-style-type: none"> ● 1* SATAII 3G/s port (SATA1) ● 1* M.2 M Key slot (M2M, type-2242/2280, SATA interface)
LAN Chip	<ul style="list-style-type: none"> ● Integrated with 1* Intel i211AT Gigabit PCI-E LAN chip ● Support Fast Ethernet LAN function of providing 10/100/1000Mbps Ethernet data transfer rate
Audio Chip	<ul style="list-style-type: none"> ● Realtek ALC662 HD Audio Codec integrated ● Audio driver and utility included
BIOS	<ul style="list-style-type: none"> ● AMI Flash ROM
Multi I/O	<p>Rear Panel I/O:</p> <ul style="list-style-type: none"> ● 1*12V DC-in Power Jack ● 1* HDMI port & 1* VGA port ● 1* Parallel port ● 1* PS/2 keyboard & mouse combo port ● 3* USB 2.0 port & 1* USB 3.0 ● 1* RJ-45 LAN port ● 2* Serial port (COM1_COM2, COM1 supports RS232/422/485) ● 1* Line-out port ● 1* MIC port <p>Internal I/O Connectors & Headers:</p> <ul style="list-style-type: none"> ● 1 *2-pin 12V internal power connector ● 1* SATA Power-out connector

- 1* CPUFAN connector & 1* SYSFAN connector
- 1* SPEAK_CON connector
- 1* Front panel header
- 1* SPK-LED header
- 1*Front panel audio header
- 1* SPDIF-Out header
- 2* 9-Pin USB 2.0 header for 4* USB 2.0 ports
- 3* RS232 serial port header (**COM3/4/5**)
- 1* GPIO header
- 1* SMBUS header
- 1* EDP header (*Co-layout with LVDS*)
- 1* LVDS header (*Co-layout with eDP*)
- 1* LVDS Inverter
- 1* LAN_LED header

1-3 Layout Diagram

Rear IO Diagram:

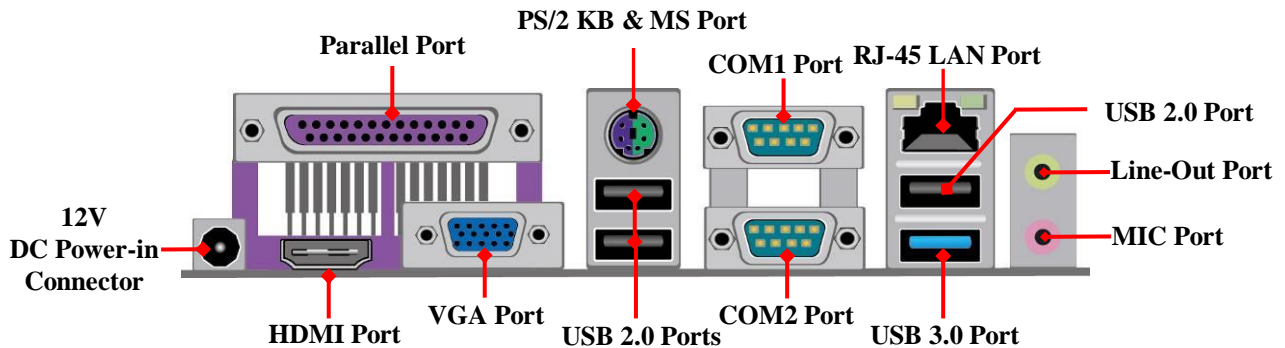

Motherboard Internal Diagram:

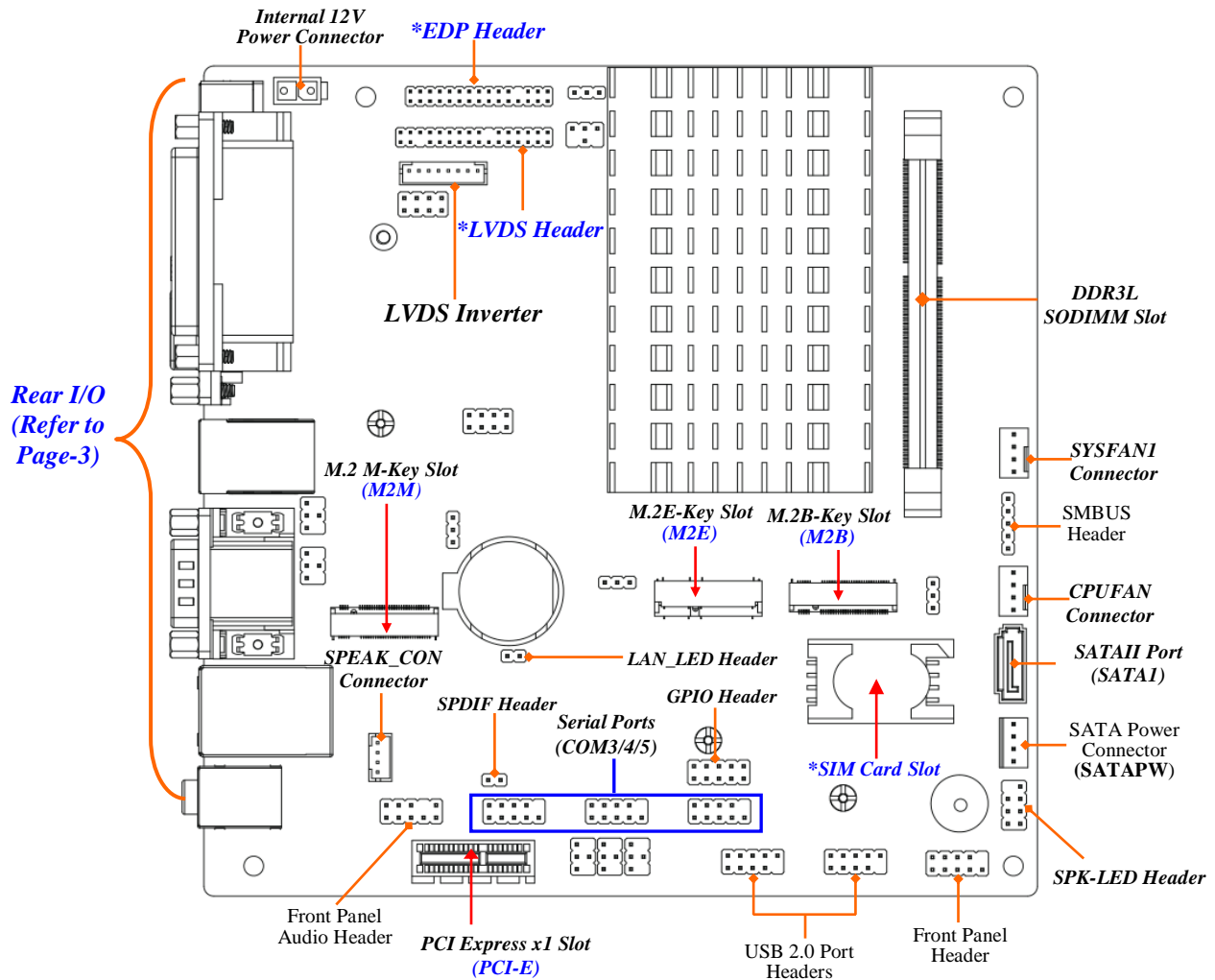

***Note:** 1. The board co-lays LVDS and EDP header; i.e. only one can function at a time. User can go to BIOS settings to select the display output ports. 2. SIM card is supported when M2B (M.2 B-Key 3042) slot is installed with 3G/4G/LTE card.

Motherboard Jumper Position:

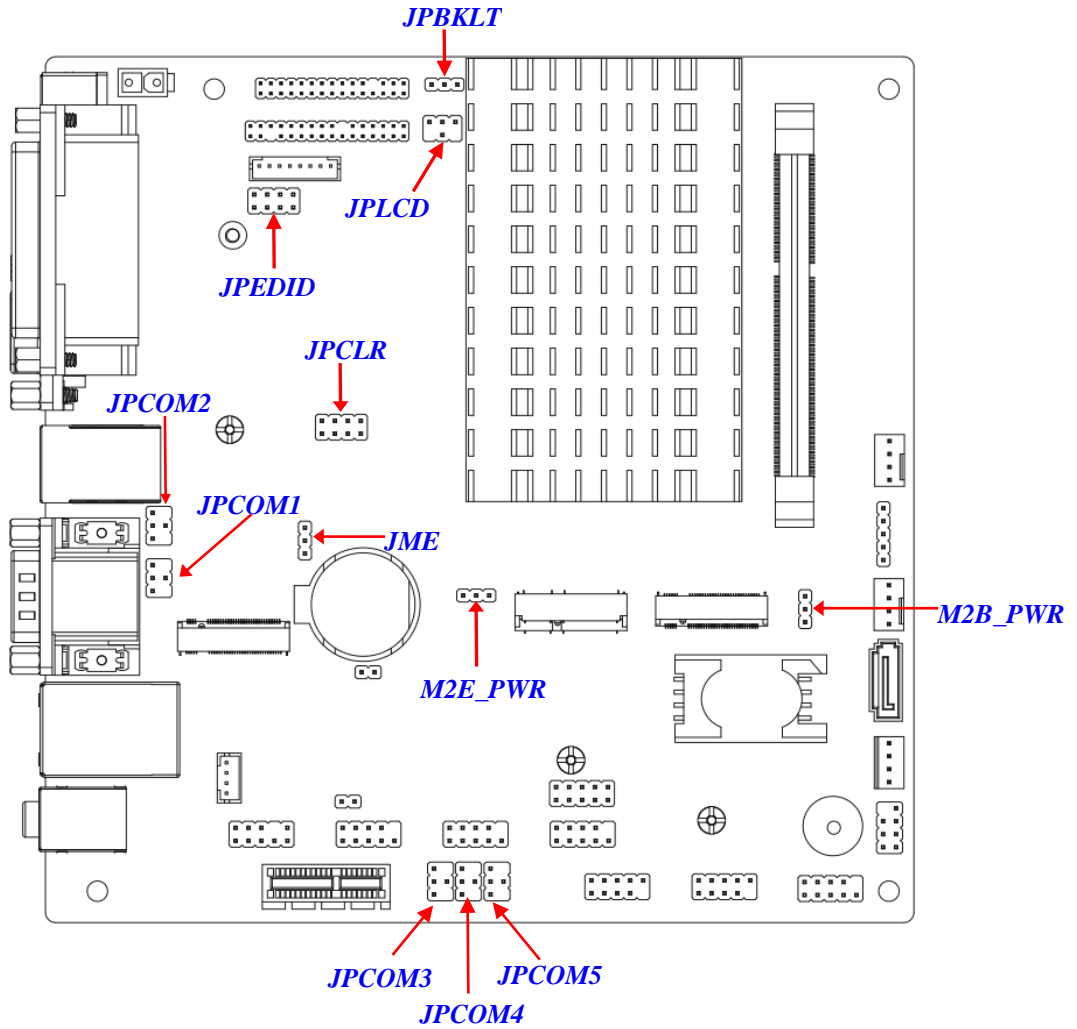

Jumper

P/N	Name	Description
JPCLR	Pin (1-2): Disabled ME Pin (3-4): Clear CMOS RAM Settings Pin (5-6): ATX/AT Mode Select Pin (7-8): Case Open Display Select	8-pin Block
JPCOM1	COM1 Port Pin-9 Function Select	4-pin Block
JPCOM2	COM2 Port Pin-9 Function Select	4-pin Block
JPCOM3	COM3 Header Pin-9 Function Select	4-pin Block
JPCOM4	COM4 Header Pin-9 Function Select	4-pin Block
JPCOM5	COM5 Header Pin-9 Function Select	4-pin Block
JME	<i>Clear ME</i>	3-pin Block
M2E_PWR	<i>M2E Slot VCC Select</i>	3-pin Block
M2B_PWR	<i>M2B Slot VCC Select</i>	3-pin Block
JPLCD	LVDS/EDP LCD Panel VCC Select	4-pin Block
JPBKL	LVDS/EDP LCD Backlight Select	3-pin Block
JPEDID	<i>EDID Resolution Select</i>	8-pin Block

Connectors

P/N	Name
DCIN	12V DC-IN Power Jack
HDMI	HDMI Port Connector
VGA	VGA Port Connector
LPT	Parallel Port Connector
PS2_USB1	Top: PS/2 Keyboard & Mouse Combo Connector Mid & Bottom: USB 2.0 Port Connector x2
UL1	Top: RJ-45 LAN Connector Middle: USB 2.0 Port Connector Bottom: USB 3.0 Port Connector
COM1_COM2	Top: RS232/422/485 Serial Port(COM1) Bottom: RS232 Serial Port (COM2)
AUDIO	Green: Line-out Connector Pink: MIC Connector
J1	Internal 12V DC-IN Power Connector

SATA1	SATAII Connector
SATAPW	SATA Power-out Connector
CPUFAN	CPUFAN Connector
SYSFAN	System Fan Connector
SPEAK_CON	3W Amplifier Connector

Headers

P/N	Name	Description
JW_FP	Front Panel Header (PWR LED/ HD LED/Power Button /Reset)	9-pin Block
SPK-LED	Power LED & Speaker Header	7-pin Block
FP_USB1/2	USB 2.0 Port Header x2	9-pin Block
GPIO_CON	GPIO Port Header	10-pin Block
SMBUS	SMBUS Header	5-pin Block
FP_AUDIO	Front Panel Audio Header	9-pin Block
SPDIF	SPDIF Out Header	2-pin Block
LAN_LED	LAN Activity LED Header	2-pin Block
COM3/4/5	Serial Port Header x3	9-pin Block
INVERTER	LVDS Inverter	8-pin Block
LVDS	LVDS Header	32-pin Block
EDP	EDP Header	29-pin Block

Chapter 2

Hardware Installation

2-1 Jumper Setting

Pin 1&2 of JPCLR (8-pin): Disable ME Settings

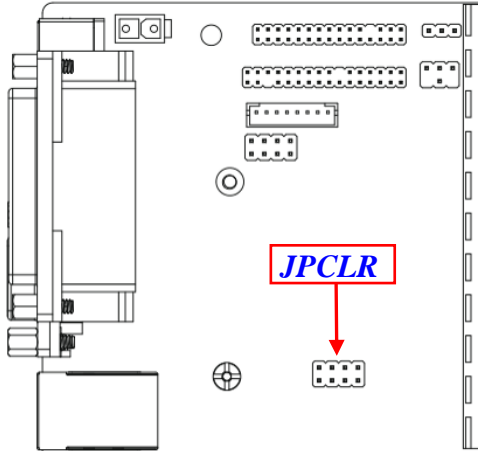

Pin 1&2 of JPCLR → Disable ME

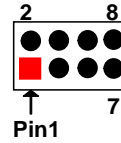

1-2 Open: Normal(Default);

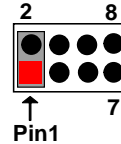

1-2 Closed: Disable ME.

Pin 3&4 of JPCLR (8-pin): Clear CMOS RAM Settings

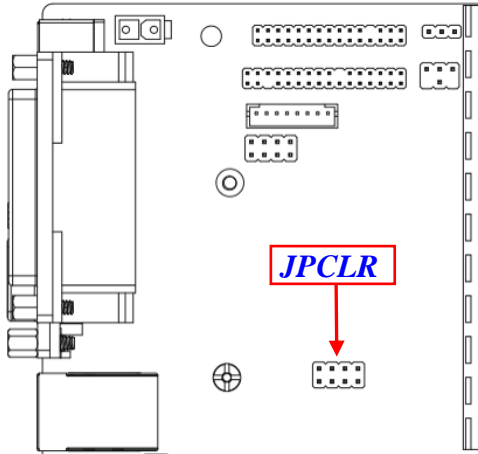

Pin 3&4 of JPCLR → Clear CMOS

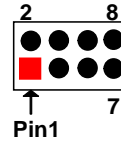

3-4 Open: Normal(Default);

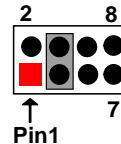

3-4 Closed: Clear CMOS(One Touch).

Pin 5&6 of JPCLR (8-pin): ATX/AT Mode Select

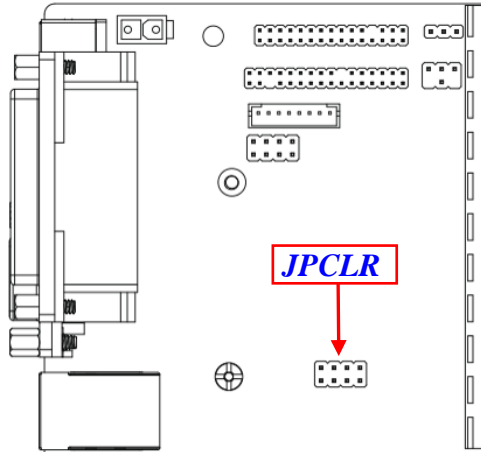

Pin 5&6 of JPCLR→ATX/AT Mode Select

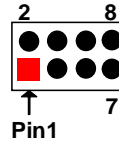

5-6 Open: ATX Mode;

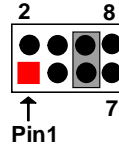

5-6 Closed: AT Mode.

***ATX Mode Selected:** Press power button to power on after power input ready;
AT Mode Selected: Directly power on as power input ready.

Pin 7&8 of JPCLR (8-pin): Case Open Message Display Function Select

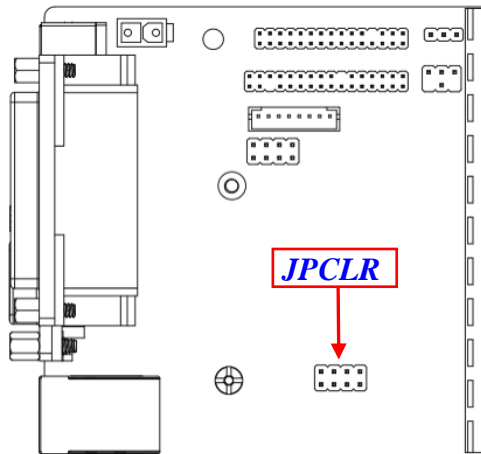

Pin 7&8 of JPCLR→Case Open Detection

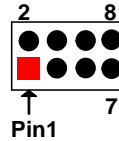

7-8 Open: Normal;

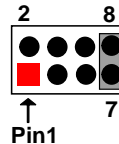

7-8 Closed: Case Open.

Pin (7&8) short: When Case open function pin short to GND, the Case open function was detected. When used, needs to enter BIOS and enable 'Case Open Detect'

function. In this case if your case is removed, next time when you restart your computer, a message will be displayed on screen to inform you of this.

JPCOM1 (4-pin): COM1 Port Pin9 Function Select

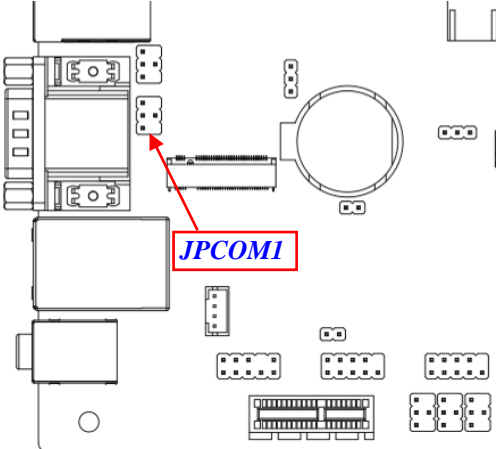

JPCOM1→COM1 Port Pin-9

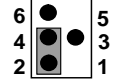
- 

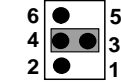
2-4 Closed:
Pin9=RI;
- 

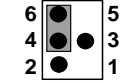
3-4 Closed:
Pin9=+5V;
- 

4-6 Closed:
Pin9=+12V.

JPCOM2 (4-pin): COM2 Port Pin9 Function Select

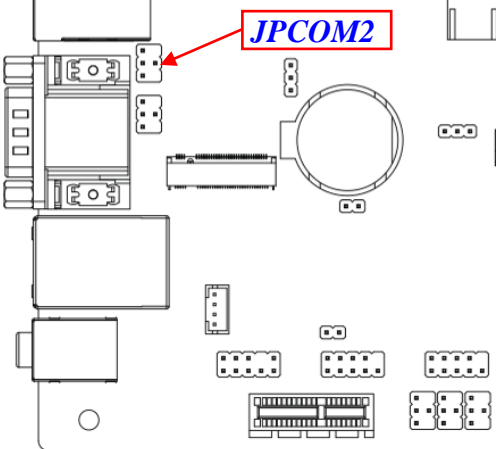

JPCOM2→COM2 Port Pin-9

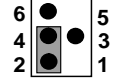
- 

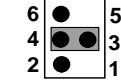
2-4 Closed:
Pin9=RI;
- 

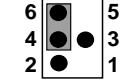
3-4 Closed:
Pin9=+5V;
- 

4-6 Closed:
Pin9=+12V.

JPCOM3 (4-pin): COM3 Header Pin9 Function Select

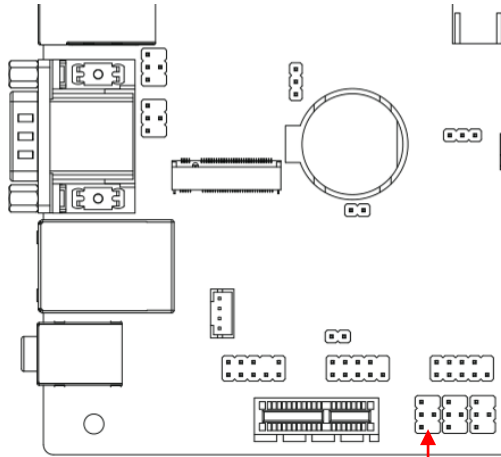

JPCOM3→COM3 Header Pin-9

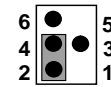

2-4 Closed:
Pin9=RI;

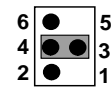

3-4 Closed:
Pin9=+5V;

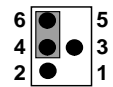

4-6 Closed:
Pin9=+12V.

JPCOM3

JPCOM4 (4-pin): COM4 Header Pin9 Function Select

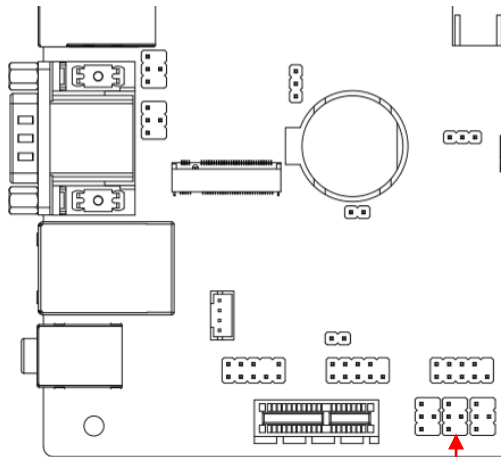

JPCOM4→COM4 Header Pin-9

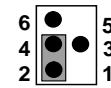

2-4 Closed:
Pin9=RI;

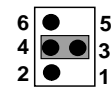

3-4 Closed:
Pin9=+5V;

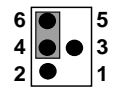

4-6 Closed:
Pin9=+12V.

JPCOM4

JPCOM5 (4-pin): COM5 Header Pin9 Function Select

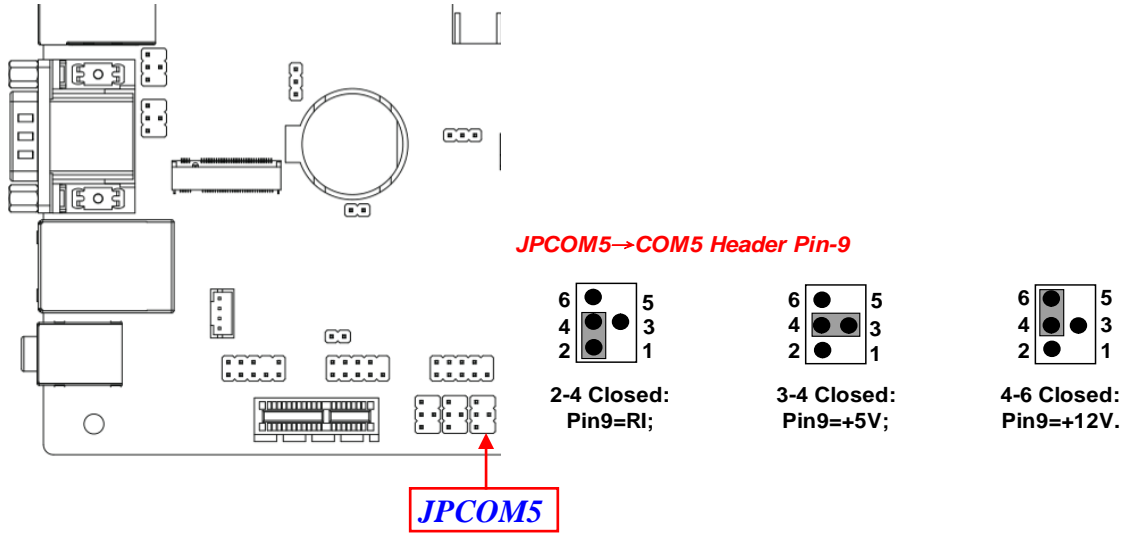

JME (3-pin): Clear ME Settings

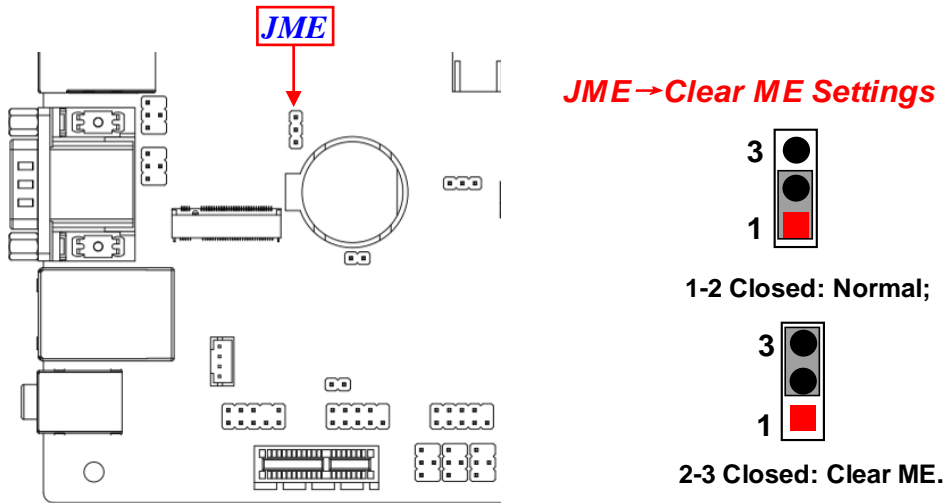

M2E_PWR (3-pin): M2E Slot VCC Select

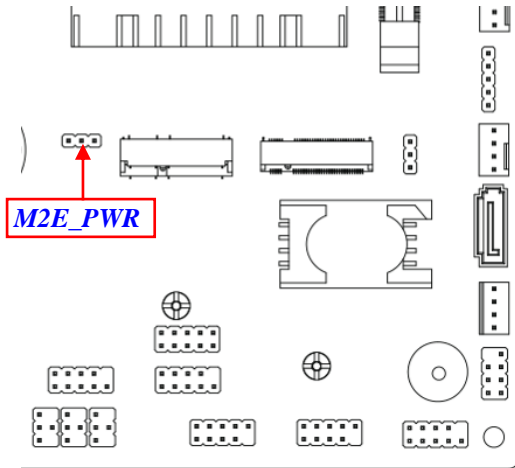

M2E_PWR → M2E Slot VCC Select

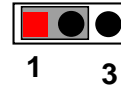

1-2 Closed: M2E Slot= 3VSB;

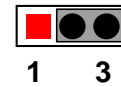

2-3 Closed: M2E Slot= VCC3.

M2B_PWR (3-pin): M2B Slot VCC Select

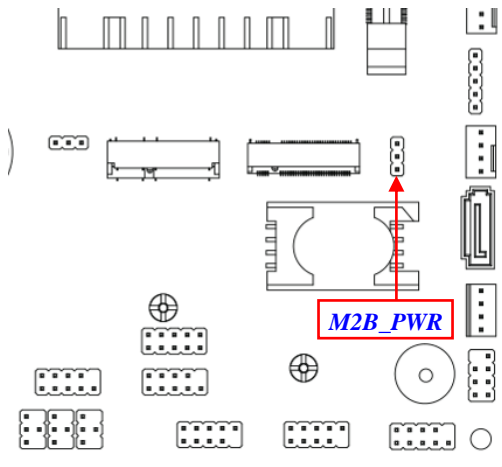

M2B_PWR → M2B Slot VCC Select

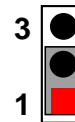

1-2 Closed: M2B Slot= VCC3;

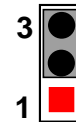

2-3 Closed: M2B Slot= 3VSB.

JPLCD (4-pin): LVDS/EDP LCD Panel VCC Select

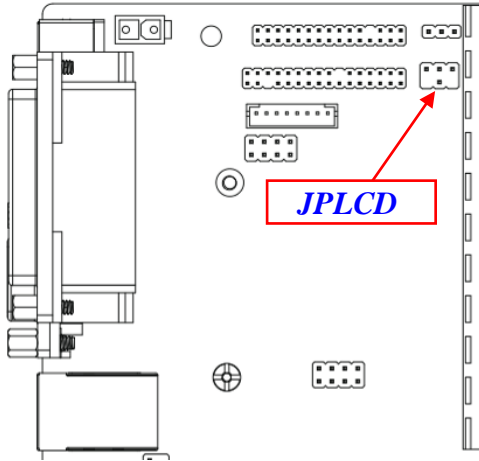

JPLCD → LVDS/EDP LCD Panel VCC

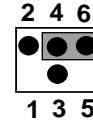
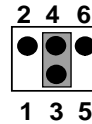
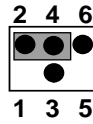

2-4 Closed: LCD VCC=3.3V; LCD VCC =+5V; LCD VCC =+12V.
3-4 Closed: LCD VCC=3.3V; LCD VCC =+5V; LCD VCC =+12V.
6-4 Closed: LCD VCC=3.3V; LCD VCC =+5V; LCD VCC =+12V.

JPBKLT(3-pin): LVDS/EDP INVERTER Backlight VCC Select

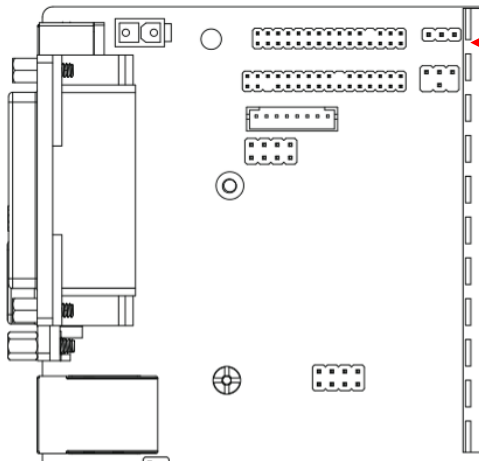

JPBKLT

JPBKLT → LVDS/EDP INVERTER Backlight VCC

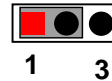

1-2 Closed: Inverter Backlight= 5V;

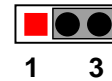

2-3 Closed: Inverter Backlight= 12V.

JPEDID(8-pin): LVDS EDID Resolution Select

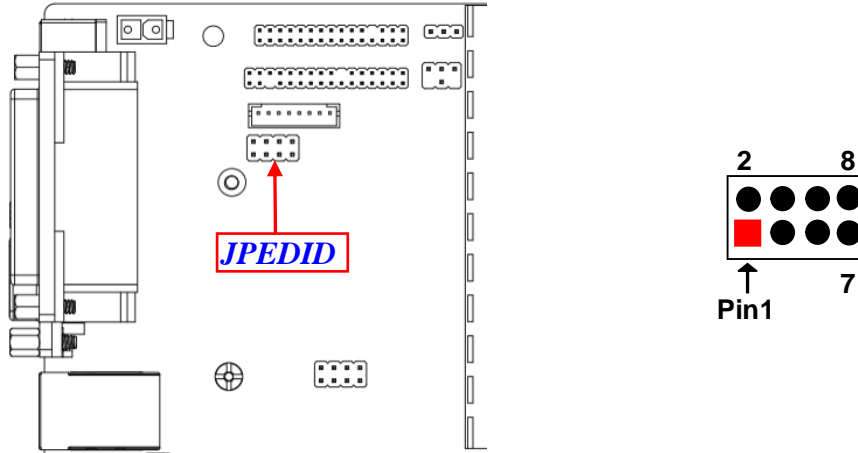

User can select **Panel** resolution by jumper settings. There are two basic setting modes:

- *Short*: in which user can close pin 1-pin2, pin3-pin4, pin5-pin6, pin7-pin8 respectively;
- *Open*: in which user leave jumper hat just in pin 2, pin4, pin6 or pin8.

Option	Jumper Setting	Description	Panel Resolution	Color Depth	Single/Dual Channel
1		Pin 1-2: Short Pin 3-4: Short Pin 5-6: Short Pin 7-8: Short	840 x 480	18-bit	Single channel
2		Pin 1-2: Open Pin 3-4: Short Pin 5-6: Short Pin 7-8: Short	840 x 600	18-bit	Single channel

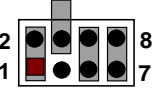
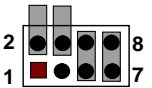
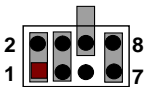
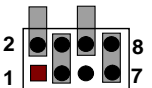
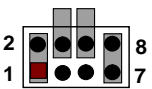
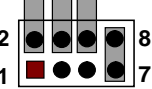
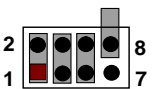
3		<p>Pin 1-2: Short Pin 3-4: Open Pin 5-6: Short Pin 7-8: Short</p>	840 x 600	24-bit	Single channel
4		<p>Pin 1-2: Open Pin 3-4: Open Pin 5-6: Short Pin 7-8: Short</p>	1024 x600	18-bit	Single channel
5		<p>Pin 1-2: Short Pin 3-4: Short Pin 5-6: Open Pin 7-8: Short</p>	1024 x768	18-bit	Single channel
6		<p>Pin 1-2: Open Pin 3-4: Short Pin 5-6: Open Pin 7-8: Short</p>	1024 x768	24-bit	Single channel
7		<p>Pin 1-2: Short Pin 3-4: Open Pin 5-6: Open Pin 7-8: Short</p>	1280 x 768	24-bit	Single channel
8		<p>Pin 1-2: Open Pin 3-4: Open Pin 5-6: Open Pin 7-8: Short</p>	1280 x 800	18-bit	Single channel
9		<p>Pin 1-2: Short Pin 3-4: Short Pin 5-6: Short Pin 7-8: Open</p>	1280 x 800	24-bit	Single channel

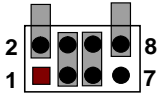
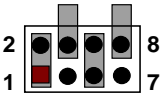
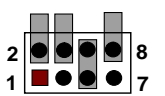
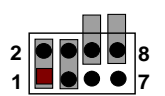
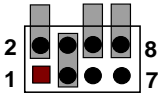
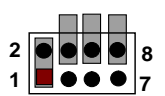
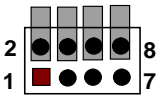





10		Pin 1-2: Open Pin 3-4: Short Pin 5-6: Short Pin 7-8: Open	1366 x 768	18-bit	Single channel
11		Pin 1-2: Short Pin 3-4: Open Pin 5-6: Short Pin 7-8: Open	1366 x 768	24-bit	Single channel
12		Pin 1-2: Open Pin 3-4: Open Pin 5-6: Short Pin 7-8: Open	1440 x 900	18-bit	Dual channel
13		Pin 1-2: Short Pin 3-4: Short Pin 5-6: Open Pin 7-8: Open	1440 x 900	24-bit	Dual channel
14		Pin 1-2: Open Pin 3-4: Short Pin 5-6: Open Pin 7-8: Open	1280 x 1024	24-bit	Dual channel
15		Pin 1-2: Short Pin 3-4: Open Pin 5-6: Open Pin 7-8: Open	1680 x 1050	24-bit	Dual channel
16		Pin 1-2: Open Pin 3-4: Open Pin 5-6: Open Pin 7-8: Open	1920 x 1080	24-bit	Dual channel

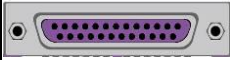

2-2 Connectors and Headers

2-2-1 Connectors

(1) Rear Panel Connectors

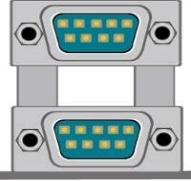
**Refer to Page-3 Rear IO Diagram.*

Icon	Name	Function
	12V DC-IN Power Jack	For user to connect compatible power adapter to provide power supply for the system.
	HDMI Port	To connect display device that support HDMI specification.
	VGA Port	To connect display device that support VGA specification.
	Parallel Port	Also called LPT connector. Mostly for user to connect printer or scanner with parallel interface.
	PS/2 Keyboard & Mouse Combo Port	This combo port is for user to connect PS/2 mouse or keyboard device to the board
	RJ-45 LAN Port	This connector is standard RJ-45 LAN jack for Network connection.
	USB 2.0 Port	To connect USB keyboard, mouse or other devices compatible with USB specification.
	USB 3.0 Port	To connect USB keyboard, mouse or other devices compatible with USB specification. USB 3.0 port supports up to 5Gbps data transfer rate.
	Serial Port	Mainly for user to connect external MODEM or other devices that supports Serial Communications Interface. <i>*Note: COM1 (Top) supports RS232/422/485 function.</i>

	Line-Out Connector	For user to connect external speaker, earphones, etc to transfer system audio output.
	MIC Connector	User can connect microphone device to this port.

(2) COM1_COM2(9-pin Block): Serial Port

COM1: RS232/422/485 Serial Port; **COM2:** RS232 Serial Port.

The pin assignment for RS-232/ 422/ 485 is listed as follows:

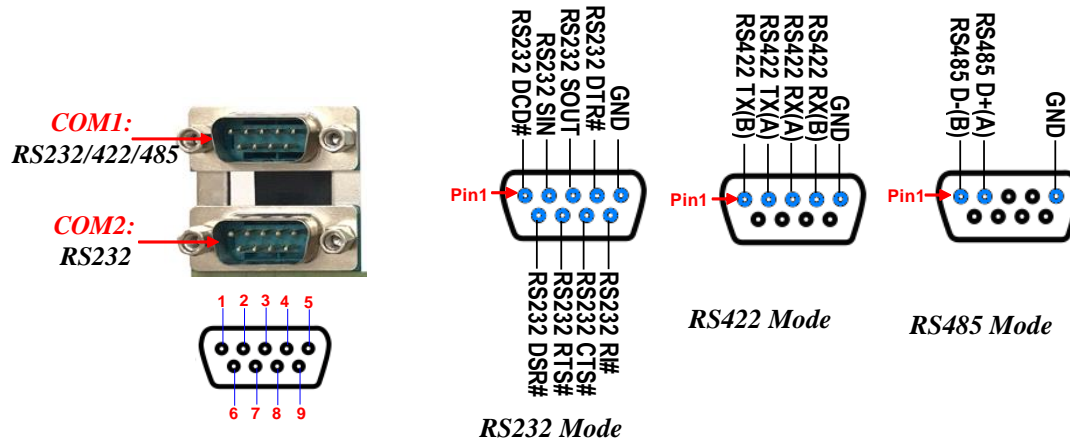

COM1 port can function as RS232/422/485 port. In normal settings COM1 functions as RS232 port. With compatible COM cable COM1 can function as RS422 or RS 485 port. User also needs to go to BIOS to set '**Transmission Mode Select**' for COM1 at first, before using specialized cable to connect different pins of this port.

(3) J1 (2-pin Block): 12V DC-in Power Connector

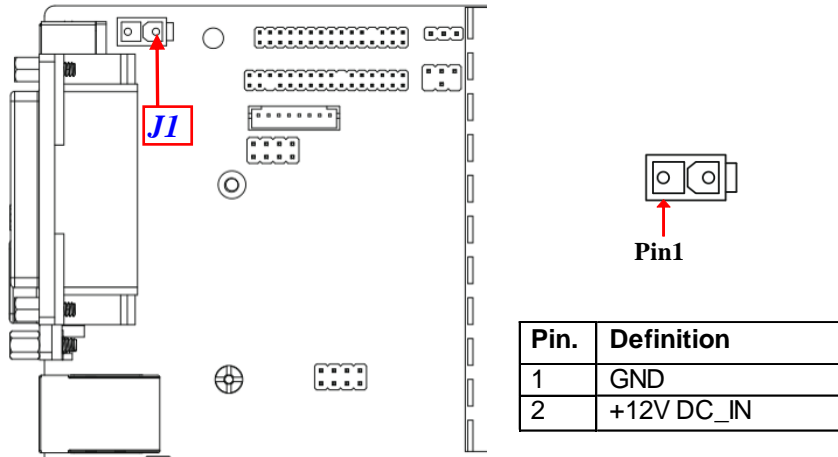

Warning: Power connection to Rear **DCIN** and Internal **J1** can not be made simultaneously. Apply compatible power cable to only one of them to power on the system.

(4) SATA1 (7-pin): SATAII Port connector

SATA1 are high-speed SATAII port that supports 3GB/s transfer rate.

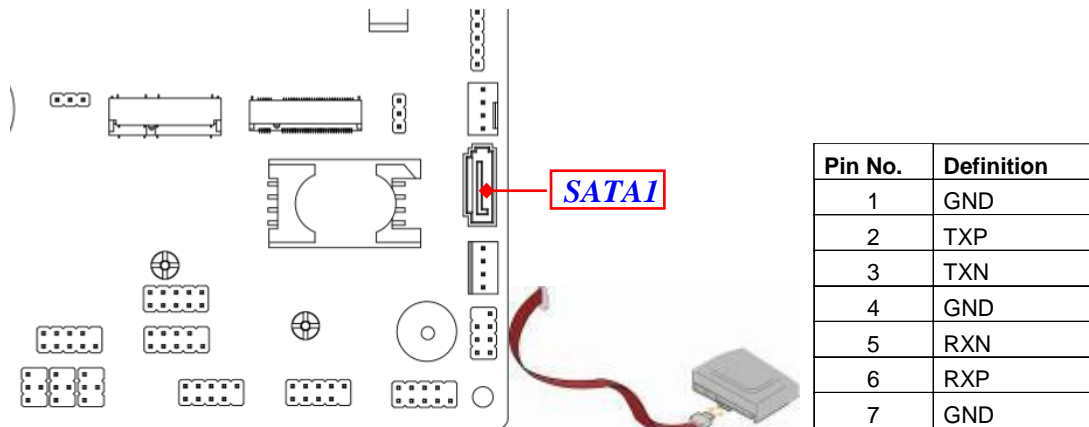

(5) SATAPW(4-pin): SATA HDD Power-Out Connector

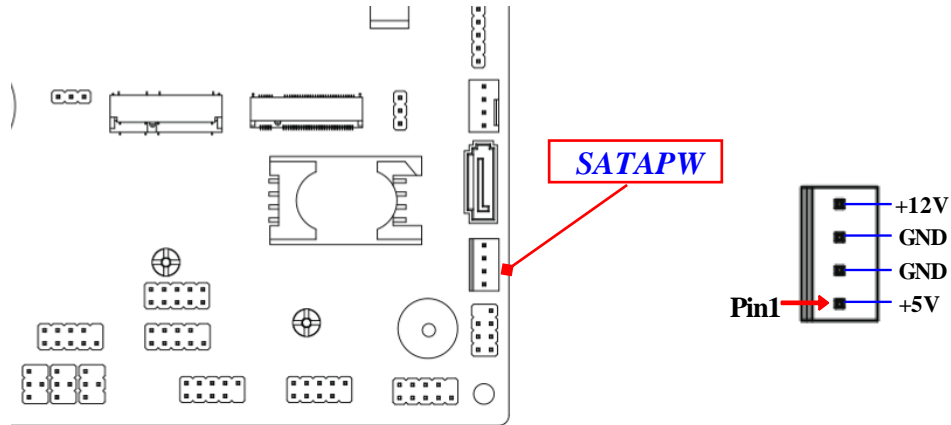

Warning: Make sure that Pin-1 of compatible SATA Power out connector is inserted into corresponding Pin-1 of **SATAPW** connector to avoid possible damage to the board and hard disk driver!

(6) CPUFAN (4-pin): CPU Fan Connector

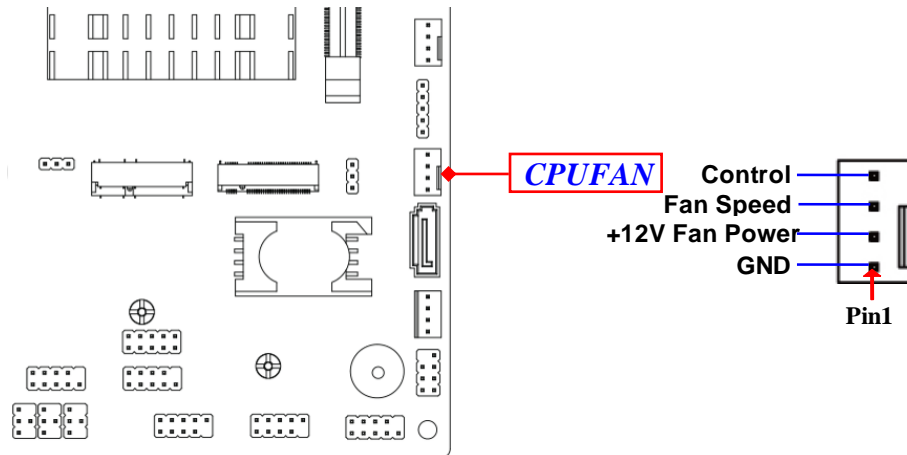

(7) SYSFAN (4-pin): System Fan Connector

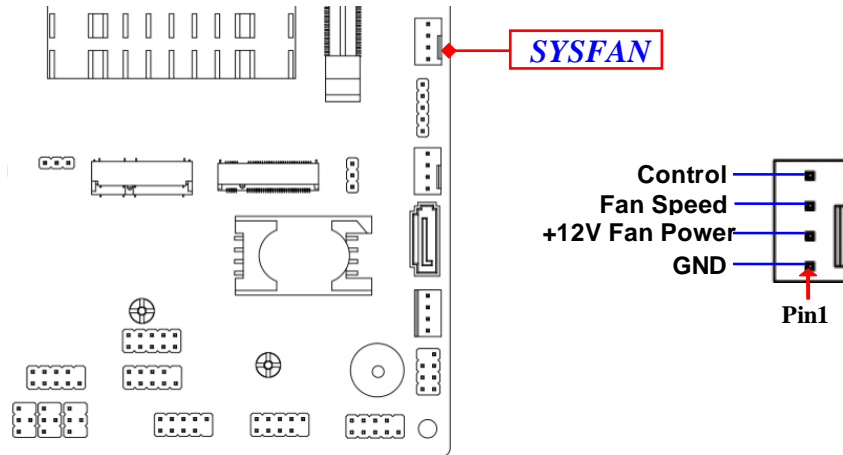

(8) SPEAK_CON (4-pin block): 3W Amplifier Connector

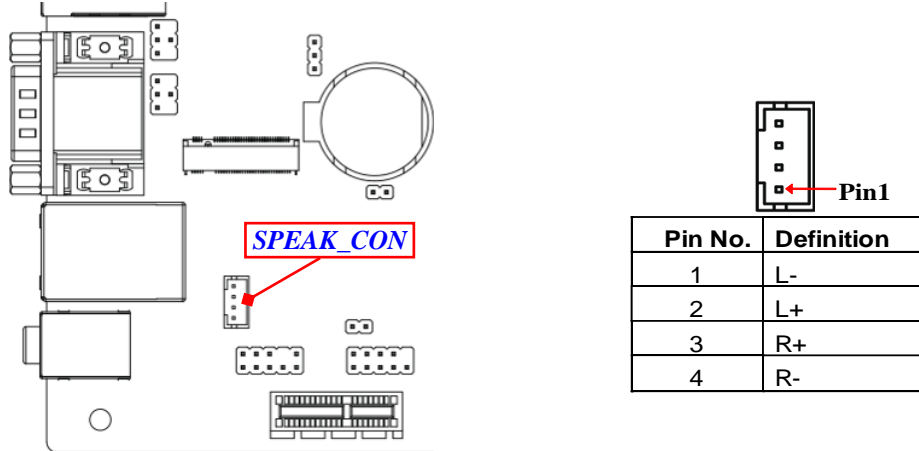

2-2-2 Headers

(1) JW_FP (9-pin): Front Panel Header

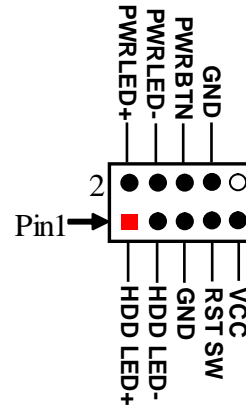
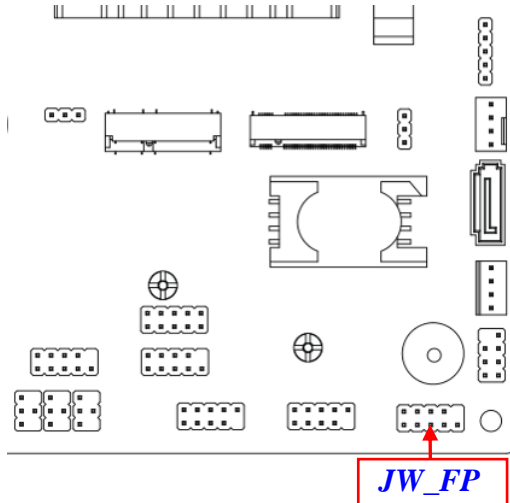

(2) SPK-LED (7-pin): Speaker Header & PWR LED Header

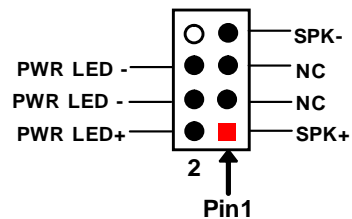
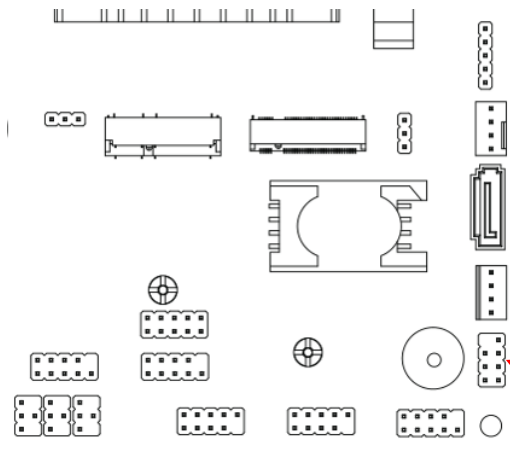

(3) FP_USB1/FP_USB2 (9-pin): USB 2.0 Port Header

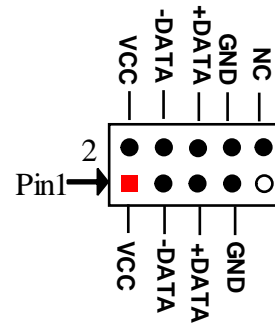
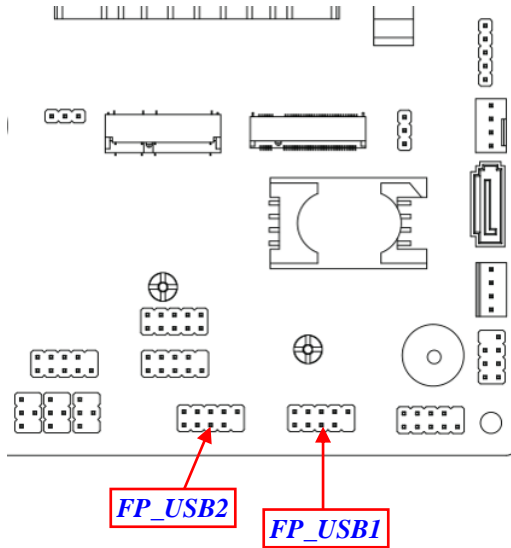

(4) GPIO_CON (10-pin): GPIO Header

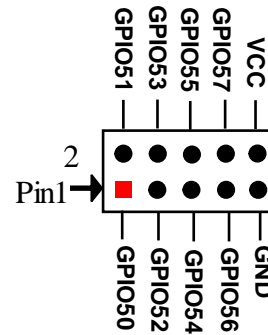
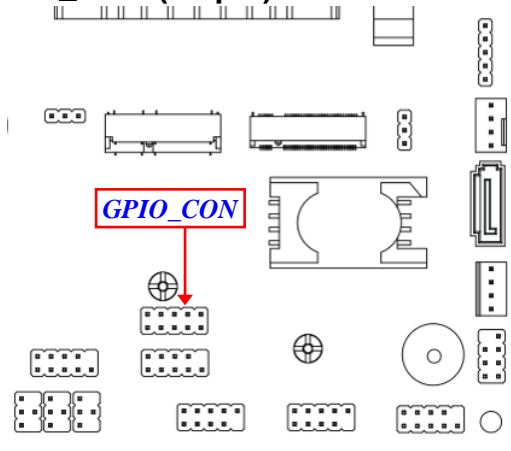

(5) SMBUS (5-Pin): SMBUS Header

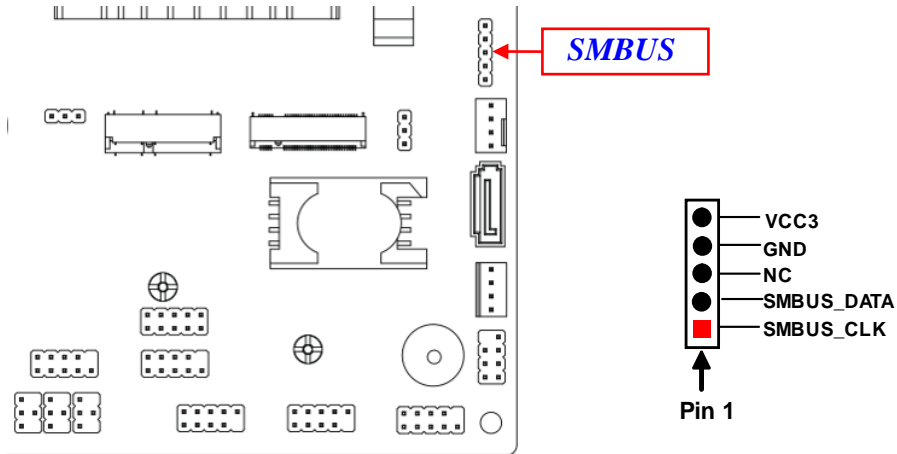

(6) FP_AUDIO (9-pin): Line-Out, MIC-In Header

This header connects to Front Panel Line-out, MIC-In connector with cable.

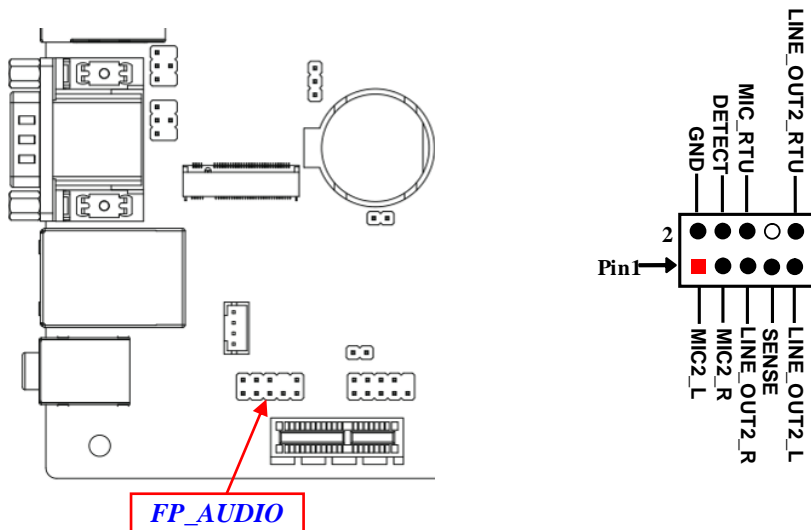

(7) SPDIF (2-pin): SPDIF Out Header

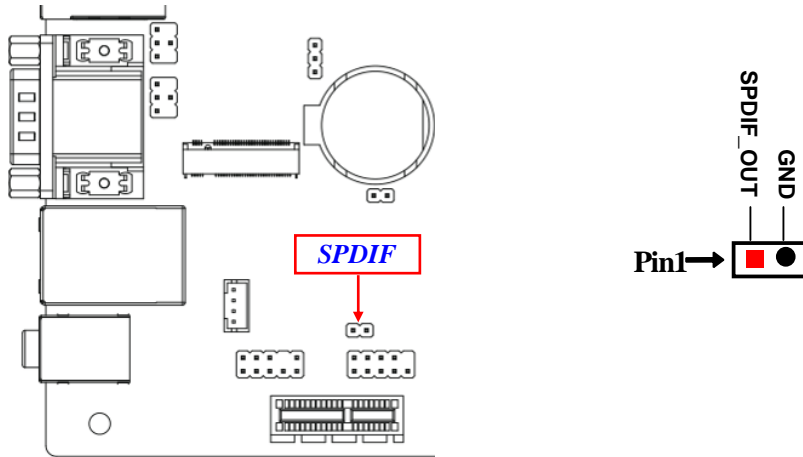

(8) LAN_LED (2-pin): LAN Activity LED Header

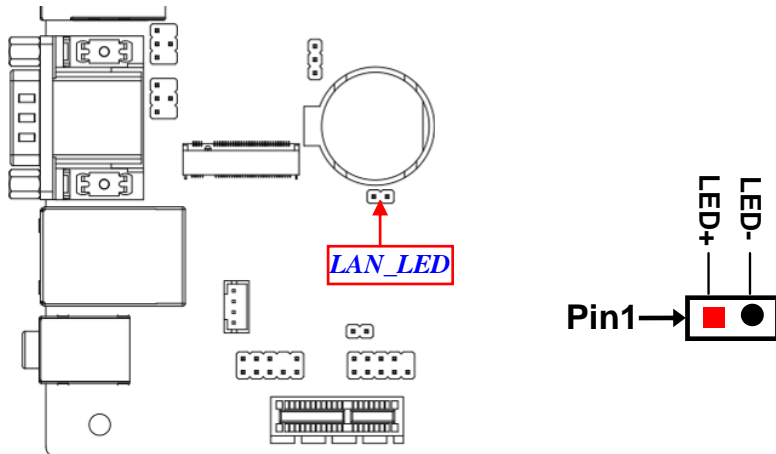

(9) COM3/COM4/COM5(9-Pin): RS232 Serial Port Header

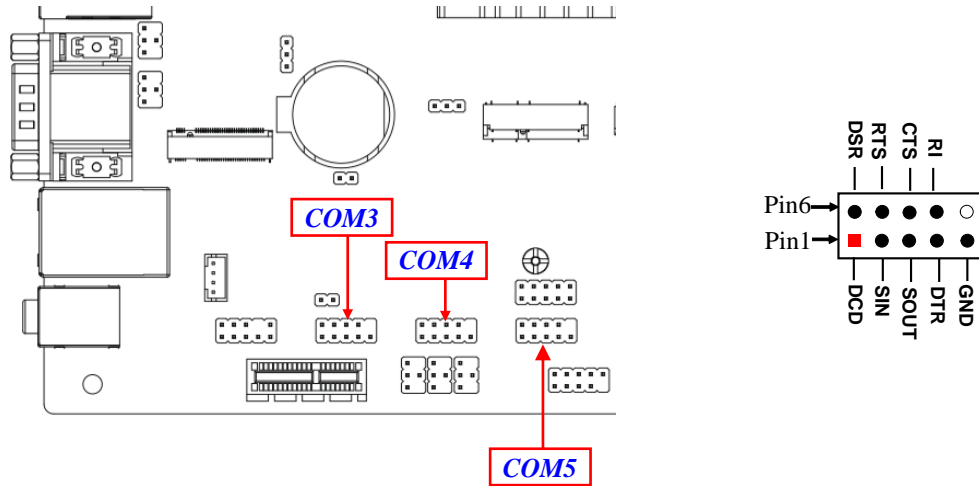

(10) INVERTER (8-pin): LVDS Inverter Connector

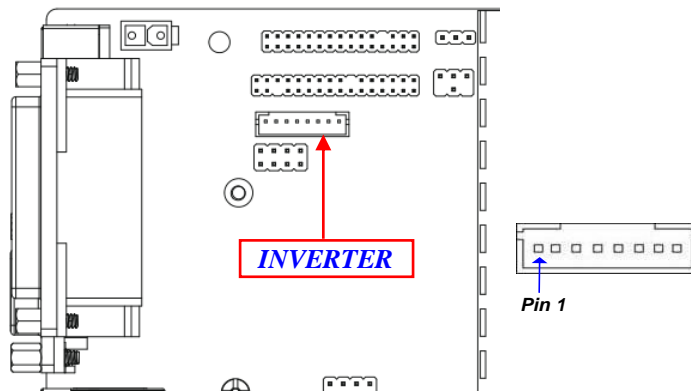

Pin No.	Definition
1	Backlight Enable
2	Backlight PWM
3	Backlight VCC
4	Backlight VCC
5	GND
6	GND
7	Backlight Up SW
8	Backlight Down SW

Warning! Find Pin-1 location of the inverter and make sure that the installation direction is correct! Otherwise serious harm will occur to the board/display panel!!

(11) LVDS (32-pin): 24-bit Dual Channel LVDS Header

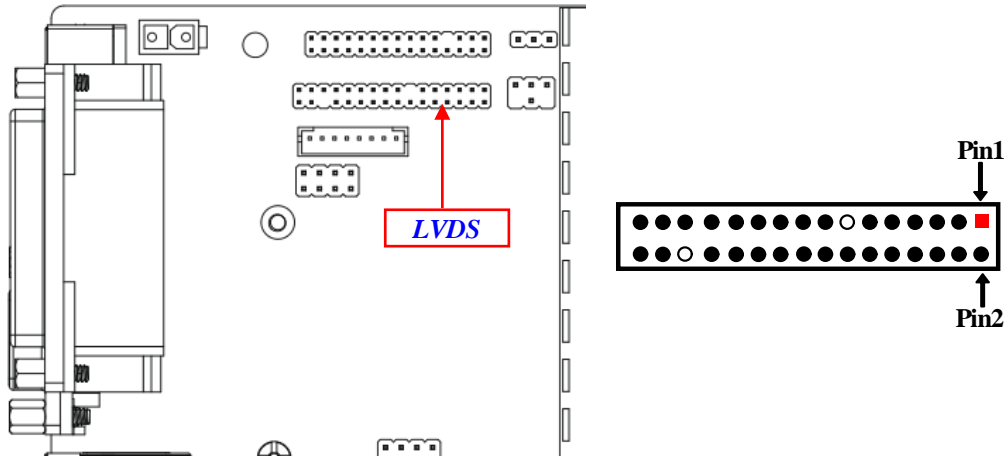

Pin Define	Pin NO.	Pin NO.	Pin Define
LVDSB_DATAN3	Pin 1	Pin 2	LVDSB_DATAP3
LVDS_CLKBN	Pin 3	Pin 4	LVDS_CLKBP
LVDSB_DATAN2	Pin 5	Pin 6	LVDSB_DATAP2
LVDSB_DATAN1	Pin 7	Pin 8	LVDSB_DATAP1
LVDSB_DATAN0	Pin 9	Pin 10	LVDSB_DATAP0
LVDS_DDC_DAT	Pin 11	Pin 12	LVDS_DDC_CLK
N/A	Pin 13	Pin 14	GND
GND	Pin 15	Pin 16	GND
LVDSA_DATAP3	Pin 17	Pin 18	LVDSA_DATAN3
LVDS_CLKAP	Pin 19	Pin 20	LVDS_CLKAN
LVDSA_DATAP2	Pin 21	Pin 22	LVDSA_DATAN2
LVDSA_DATAP1	Pin 23	Pin 24	LVDSA_DATAN1
LVDSA_DATAP0	Pin 25	Pin 26	LVDSA_DATAN0
PVDD	Pin 27	Pin 28	N/A
PVDD	Pin 29	Pin 30	PVDD
GND	Pin 31	Pin 32	GND

***Note:** The board co-lays **LVDS** and **EDP** header; i.e. only one can function at a time. User can go to BIOS settings to select the display output ports.

(12) EDP (29-pin): EDP Header

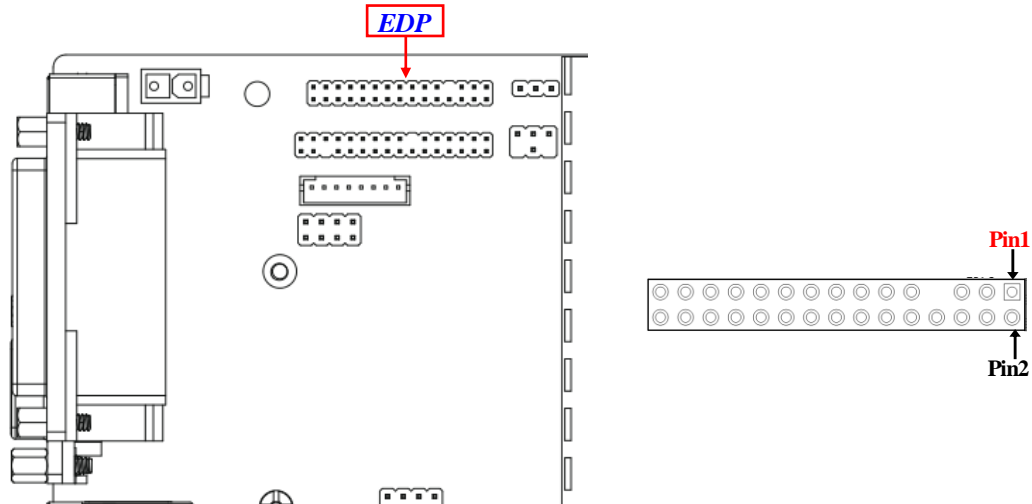

Pin Define	Pin NO.	Pin NO.	Pin Define
BKLT_PW	Pin 1	Pin 2	BKLT_PW
BKLT_PW	Pin 3	Pin 4	GND
GND	Pin 5	Pin 6	EDP_DETL
N/A	Pin 7	Pin 8	EDP_SCL
EDP_VCC	Pin 9	Pin 10	EDP_SDA
EDP_VCC	Pin 11	Pin 12	EDP_BKLT_CTL
GND	Pin 13	Pin 14	GND
EDP_BKLT_EN	Pin 15	Pin 16	EDP_AUXP_C
EDP_HPD	Pin 17	Pin 18	EDP_AUXN_C
GND	Pin 19	Pin 20	GND
EDP_LANE+3	Pin 21	Pin 22	EDP_LANE-3
EDP_LANE+2	Pin 23	Pin 24	EDP_LANE-2
GND	Pin 25	Pin 26	GND
EDP_LANE+1	Pin 27	Pin 28	EDP_LANE-1
EDP_LANE+0	Pin 29	Pin 30	EDP_LANE-0

***Note:** The board co-lays **LVDS** and **EDP** header; i.e. only one can function at a time. User can go to BIOS settings to select the display output ports.

Chapter 3

Introducing BIOS

Notice! The BIOS options in this manual are for reference only. Different configurations may lead to difference in BIOS screen and BIOS screens in manuals are usually the first BIOS version when the board is released and may be different from your purchased motherboard. Users are welcome to download the latest BIOS version form our official website.

The BIOS is a program located on a Flash Memory on the motherboard. This program is a bridge between motherboard and operating system. When you start the computer, the BIOS program will gain control. The BIOS first operates an auto-diagnostic test called POST (power on self test) for all the necessary hardware, it detects the entire hardware device and configures the parameters of the hardware synchronization. Only when these tasks are completed done it gives up control of the computer to operating system (OS). Since the BIOS is the only channel for hardware and software to communicate, it is the key factor for system stability, and in ensuring that your system performance as its best.

3-1 Entering Setup

Power on the computer and by pressing immediately allows you to enter Setup. If the message disappears before your respond and you still wish to enter Setup, restart the system to try again by turning it OFF then ON or pressing the “RESET” button on the system case. You may also restart by simultaneously pressing <Ctrl>, <Alt> and <Delete> keys. If you do not press the keys at the correct time and the system does not boot, an error message will be displayed and you will again be asked to

Press **** to enter Setup/ Press **<F7>** to enter Popup Menu.

3-2 BIOS Menu Screen

The following diagram show a general BIOS menu screen:

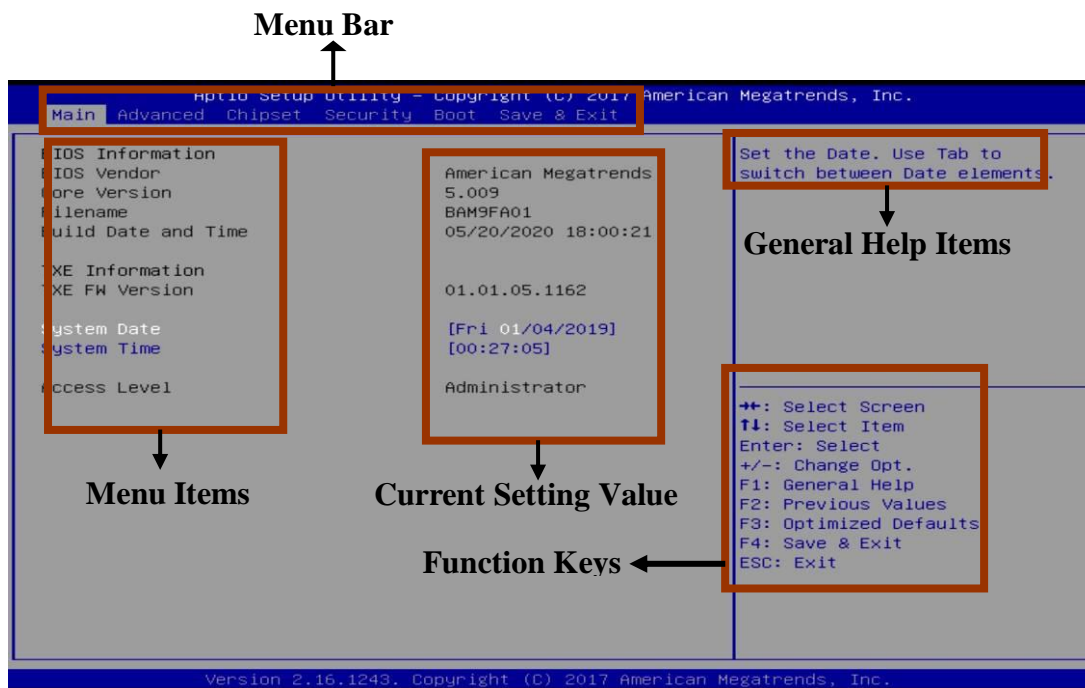

3-3 Function Keys

In the above BIOS Setup main menu of, you can see several options. We will explain these options step by step in the following pages of this chapter, but let us first see a short description of the function keys you may use here:

- Press ←→ (left, right) to select screen;
- Press ↑↓ (up, down) to choose, in the main menu, the option you want to confirm or to modify.
- Press <Enter> to select.

-
- Press <+>/<-> keys when you want to modify the BIOS parameters for the active option.
 - [F1]: General help.
 - [F2]: Previous value.
 - [F3]: Optimized defaults.
 - [F4]: Save & Exit.
 - Press <Esc> to quit the BIOS Setup.

3-4 Getting Help

Main Menu

The on-line description of the highlighted setup function is displayed at the top right corner the screen.

Status Page Setup Menu/Option Page Setup Menu

Press [F1] to pop up a small help window that describes the appropriate keys to use and the possible selections for the highlighted item. To exit the Help Window, press <Esc>.

3-5 Menu Bars

There are six menu bars on top of BIOS screen:

Main	To change system basic configuration
Advanced	To change system advanced configuration
Chipset	To change chipset configuration
Security	Password settings
Boot	To change boot settings
Save & Exit	Save setting, loading and exit options.

User can press the right or left arrow key on the keyboard to switch from menu bar. The selected one is highlighted.

3-6 Main Menu

Main menu screen includes some basic system information. Highlight the item and then use the <+> or <-> and numerical keyboard keys to select the value you want in each item.

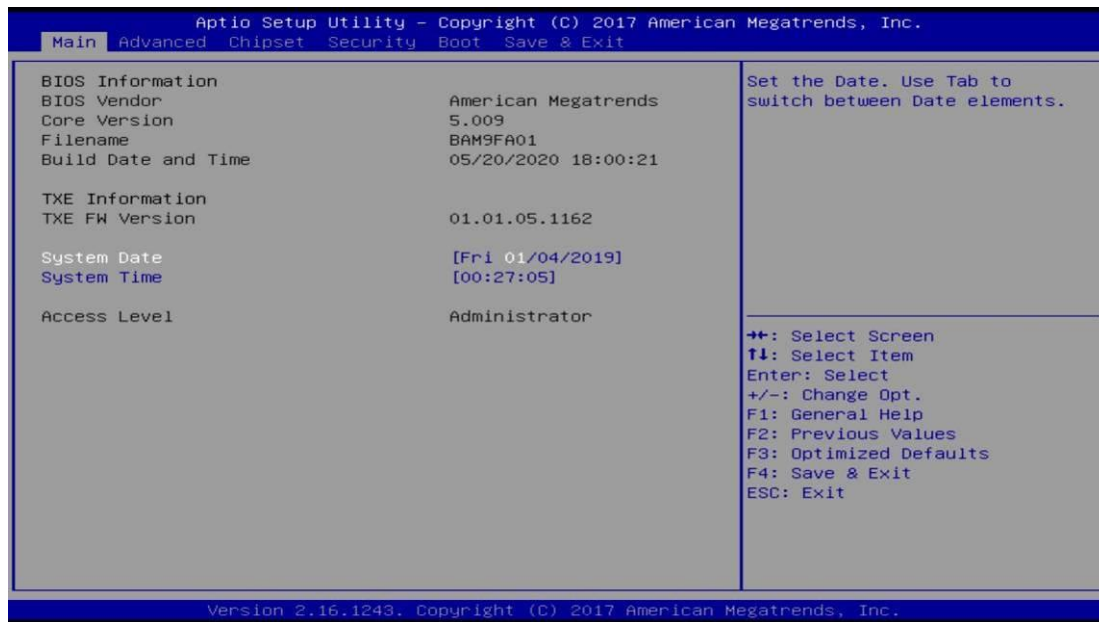

System Date

Set the date. Please use [Tab] to switch between date elements.

System Time

Set the time. Please use [Tab] to switch between time elements.

3-7 Advanced Menu

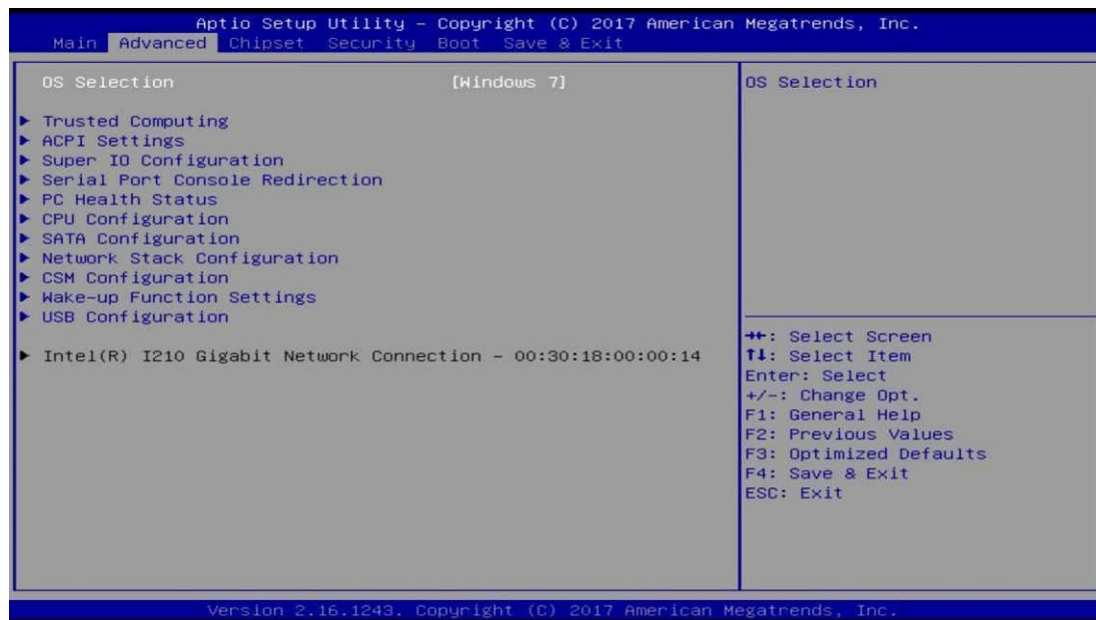

OS Selection

The optional settings: [Windows 8.X]; [Linux/Android]; [Windows 7].

* **Note:** User need to go to this item to select the OS mode before installing corresponding OS driver, otherwise problems will occur when installing the driver.

▶ Trusted Computing

Press [Enter] to enable or disable 'Security Device Support'.

Security Device Support

Use this item to enable or disable BIOS support for security device. O.S. will not show Security Device. TCG EFI protocol and INT1A interface will not be available. The optional settings: [Disabled]; [Enabled].

***Note:** 'Security Device Support' item is only available for motherboards with TPM function support.

TPM20 Device Found

HashPolicy

***Note:** When set as **[Enabled]**, TPM20 Device will show up for motherboards with TPM support.

This item is inactive default settings with no change access.

▶ **ACPI Settings**

Press [Enter] to make settings for the following sub-item:

ACPI Settings

ACPI Sleep State

Use this item to select the highest ACPI sleep state the system will enter when the suspend button is pressed.

The optional settings are: [Suspend Disabled]; [S3 (Suspend to RAM)].

▶ **Super I/O Configuration**

Press [Enter] to make settings for the following sub-items:

Super IO Configuration

▶ **Serial Port 1 Configuration**

Press [Enter] to make settings for the following items:

Serial Port 1 Configuration

Serial Port

Use this item to enable or disable Serial Port (COM).

The optional settings: [Disabled]; [Enabled].

When set as [Enabled], user can make further settings in the following items:

Change Settings

Use this item to select an optimal setting for Super IO Device.

The optional settings: [Auto]; [IO=3F8h; IRQ=4]; [IO=2F8h; IRQ=3]; [IO=3E8h; IRQ=4]; [IO=2E8h; IRQ=3].

Transmission Mode Select

The optional settings: [RS422]; [RS232]; [RS485].

Mode Speed Select

The optional settings: [RS232/RS422/RS485=250Kbps]; [RS232=1Mbps, RS422/RS485=10Mbps].

Serial Port FIFO Mode

The optional settings: [16-Byte FIFO]; [32-Byte FIFO]; [64-Byte FIFO]; [128-Byte

FIFO].

▶ **Serial Port 2 Configuration/ Serial Port 3 Configuration/ Serial Port 4 Configuration/ Serial Port 5 Configuration**

Press [Enter] to make settings for the following items:

Serial Port 2/3/4/5 Configuration

Serial Port

Use this item to enable or disable Serial Port (COM).

The optional settings: [Disabled]; [Enabled].

When set as [Enabled], user can make further settings in the following items:

Change Settings

Use this item to select an optimal setting for super IO device.

The optional settings: [Auto]; [IO=3F8h; IRQ=4]; [IO=2F8h; IRQ=3]; [IO=3E8h; IRQ=4]; [IO=2E8h; IRQ=3] for '**Serial Port 2 Confoguration**'.

The optional settings: [Auto]; [IO=3F8h; IRQ=10]; [IO=2F8h; IRQ=10]; [IO=3E8h; IRQ=10]; [IO=2E8h; IRQ=10]; [IO=220h; IRQ=10]; [IO=228h; IRQ=10] for '**Serial Port 3/4/5 Confoguration**'.

Serial Port FIFO Mode

The optional settings: [16-Byte FIFO]; [32-Byte FIFO]; [64-Byte FIFO]; [128-Byte FIFO].

▶ **Parallel Port Configuration**

Press [Enter] to make settings for the following items:

Parallel Port Configuration

Parallel Port

Use this item to enable or disable Parallel Port (LPT/LPTE).

The optional settings: [Disabled]; [Enabled].

When set as [Enabled], user can make further settings in the following items:

Change Settings

Use this item to select an optimal setting for Super IO Device.

The optional settings: [Auto]; [IO=378h; IRQ=5]; [IO=378h; IRQ=5,6,7,9,10,11,12]; [IO=278h; IRQ=5,6,7,9,10,11,12]; [IO=3BCh; IRQ=5,6,7,9,10,11,12].

Device Mode

The optional settings: [STD Printer Mode]; [SPP Mode]; [EPP-1.9 and SPP Mode]; [EPP-1.7 and SPP Mode]; [ECP Mode]; [ECP and EPP 1.9 Mode]; [ECP and EPP 1.7 Mode].

OS Select for Serial Port

The optional settings: [Windows]; [LINUX].

ERP Support

Use this item to select Energy-Related Products function. This item should be set as [Disabled] if you wish to have all active wake-up functions.

The optional settings: [Disabled]; [Enabled].

Case Open Detect

Use this item to detect if case have ever been opened. Show message in POST.

The optional settings: [Disabled]; [Enabled].

When set as [Enabled], system will detect if COPEN has been short or not (*refer to JPCLR jumper for case open detection*); if COPEN is short, system will show Case Open Message during POST.

PS2 KB/MS Connect

Use this item to make settings for PS2 Connect Primary Devices.

The optional settings: [Keyboard First]; [Mouse First].

WatchDog Reset Timer

Use this item to enable or disable WDT reset function. When set as [Enabled], the following sub-items shall appear:

WatchDog Reset Timer Value

User can select a value in the range of [10] to [255] seconds when 'WatchDog Reset Timer Unit' set as [Sec]; or in the range of [10] to [255] minutes when 'WatchDog Reset Timer Unit' set as [Min].

WatchDog Reset Timer Unit

The optional settings: [Sec.]; [Min.].

WatchDog Wake-up Timer

The optional settings: [Disabled]; [Enabled].

When set as [Enabled], the following sub-items shall appear:

WatchDog Wake-up Timer Value

User can select a value in the range of [10] to [4095] seconds when 'WatchDog Wake-up Timer Unit' set as [Sec]; or in the range of [1] to [4095] minutes when 'WatchDog Wake-up Timer Unit' set as [Min].

WatchDog Wake-up Timer Unit

The optional settings: [Sec.]; [Min.].

ATX Power Emulate AT Power

This item support Emulate AT power function, MB power On/Off control by power supply. Use needs to select 'AT or ATX Mode' on MB jumper at first (*refer to JPCLR jumper setting for ATX Mode & AT Mode Select*).

▶ **Serial Port Console Redirection**

Press [Enter] to make settings for the following sub-items:

COM1

Console Redirection

Use this item to enable or disable COM1 Console Redirection.

The optional settings: [Disabled]; [Enabled].

When set as [Enabled], user can make further settings in the following items:

▶ **Console Redirection Settings**

The settings specify how the host computer and the remote computer (which the user is using) will exchange data. Both computers should have the same or compatible settings.

Press [Enter] to make settings for the following sub-items.

Terminal Type

The optional settings: [VT100]; [VT100+]; [VT-UTF8]; [ANSI].

Emulation: **[ANSI]**: Extended ASCII char set; **[VT100]**: ASCII char set;

[VT100+]: Extends VT100 to support color, function keys, etc.; **[VT-UTF8]**:

Uses UTF8 encoding to map Unicode chars onto 1 or more bytes.

Bits per second

Use this item to select serial port transmission speed. The speed must be matched on the other side. Long or noisy lines may require lower speeds.

The optional settings: [9600]; [19200]; [38400]; [57600]; [115200].

Data Bits

The optional settings: [7]; [8].

Parity

A parity bit can be sent with the data bits to detect some transmission errors.

The optional settings: [None]; [Even]; [Odd]; [Mark]; [Space].

[Even]: parity bit is 0 if the num of 1's in the data bits is even;

[Odd]: parity bit is 0 if num of 1's in the data bits is odd;

[Mark]: parity bit is always 1;

[Space]: parity bit is always 0;

[Mark] and **[Space]**: parity do not allow for error detection.

Stop Bits

Stop bits indicate the end of a serial data packet. (A start bit indicates the beginning). The standard setting is 1 stop bit. Communication with slow devices may require more than 1 stop bit.

The optional settings: [1]; [2].

Flow Control

Flow control can prevent data loss from buffer overflow. When sending data, if the receiving buffers are full, a “stop” signal can be sent to stop the data flow. Once the buffers are empty, a “start” signal can be sent to re-start the flow. Hardware flow control uses two wires to send start/stop signals.

The optional settings: [None]; [Hardware RTS/CTS].

VT-UTF8 Combo Key Support

Use this item to enable VT-UTF8 Combination Key Support for ANSI/VT100 terminals.

The optional settings: [Disabled]; [Enabled].

Recorder Mode

With this mode enable only text will be sent. This is to capture Terminal data.

The optional settings: [Disabled]; [Enabled].

Resolution 100x31

Use this item to enable or disable extended terminal resolution.

The optional settings: [Disabled]; [Enabled].

Putty Keypad

Use this item to select FunctionKey and Keypad on Putty.

The optional settings: [VT100]; [LINUX]; [XTERMR6]; [SCO]; [ESCN]; [VT400].

Serial Port for Out-of-Band Management/ Windows Emergency Management Services (EMS)

Console Redirection

The optional settings: [Disabled]; [Enabled].

When set as [Enabled], user can make further settings in the following items:

▶ **Console Redirection Settings**

The settings specify how the host computer and the remote computer (which the user is using) will exchange data. Both computers should have the same or compatible settings.

Press [Enter] to make settings for the following sub-items.

Out-of-Band Mgmt Port

The default setting is: [COM1].

Terminal Type

The optional settings: [VT100]; [VT100+]; [VT-UTF8]; [ANSI].

[VT-UTF8] is the preferred terminal type for out-of-band management. The next best choice is **[VT100+]** and then **[VT100]**. See above, in Console Redirection Settings page, for more help with Terminal Type/Emulation.

Bits per second

Use this item to select serial port transmission speed. The speed must be matched on the other side. Long or noisy lines may require lower speeds.

The optional settings: [9600]; [19200]; [57600]; [115200].

Flow Control

Flow control can prevent data loss from buffer overflow. When sending data, if the receiving buffers are full, a “stop” signal can be sent to stop the data flow. Once the buffers are empty, a “start” signal can be sent to re-start the flow. Hardware flow control uses two wires to send start/stop signals.

The optional settings: [None]; [Hardware RTS/CTS]; [Software Xon/Xoff].

Data Bits

The default setting is: [8].

**This item may or may not show up, depending on different configuration.*

Parity

The default setting is: [None].

**This item may or may not show up, depending on different configuration.*

Stop Bits

The default setting is: [1].

**This item may or may not show up, depending on different configuration.*

▶ **PC Health Status**

Press [Enter] to view current hardware health status, make further settings in 'SmartFAN Configuration' and set value in 'Shutdown Temperature'.

▶ **SmartFAN Configuration**

Press [Enter] to make settings for SmartFan Configuration:

SmartFAN Configuration

CPUFAN / SYSFAN1 Smart Mode

The optional settings: [Disabled]; [Enabled].

When set as [Enabled], the following sub-items shall appear:

CPUFAN / SYSFAN1 Full-Speed Temperature

Use this item to set CPUFAN/SYSFAN full speed temperature. Fan will run at full speed when above this pre-set temperature.

CPUFAN / SYSFAN1 Full-Speed Duty

Use this item to set CPUFAN/SYSFAN full-speed duty. Fan will run at full speed when above this pre-set duty.

CPUFAN / SYSFAN1 Idle-Speed Temperature

Use this item to set CPUFAN /SYSFAN idle speed temperature. Fan will run at idle speed when below this pre-set temperature.

CPUFAN / SYSFAN1 Idle-Speed Duty

Use this item to set CPUFAN/SYSFAN idle speed duty. Fan will run at idle speed when below this pre-set duty.

Shutdown Temperature

Use this item to select system shutdown temperature.

The optional settings: [Disabled]; [65°C/149°F]; [70°C/158°F]; [75°C/167°F]; [80°C/176°F]; [85°C/185°F].

▶ **CPU Configuration**

Press [Enter] to view current CPU configuration and make settings for the following sub-items:

Limit CPUID Maximum

The optional settings: [Disabled]; [Enabled].

This item should be set as **[Disabled]** for Windows XP.

Execute Disable Bit

XD can prevent certain classed of malicious buffer overflow attacks when combined with a supporting OS (Windows Server 2003 SP1, Windows XP SP2, SuSE Linux 9.2, RedHat Enterprise 3 Update 3.)

The optional settings: [Disabled]; [Enabled].

Hardware Prefetcher

Use this item to enable the Mid Level Cache (L2) streamer prefetcher.

The optional settings: [Disabled]; [Enabled].

Adjacent Cache Line Prefetch

Use this item to enable the Mid Level Cache (L2) prefetching of adjacent cache lines.

The optional settings: [Disabled]; [Enabled].

EIST

Use this item to enable or disable Intel SpeedStep.

The optional settings: [Disabled]; [Enabled].

CPU C State Report

Use this item to enable or disable CPU C state report to OS.

The optional settings: [Disabled]; [Enabled].

When set as [Enabled], the following item shall appear:

Enhanced C state

Use this item to enable or disable Enhanced CPU C state.

The optional settings: [Disabled]; [Enabled].

Max CPU C State

This option controls Max C state that the processor will support.

The optional settings: [C7]; [C6]; [C1].

▶ **SATA Configuration**

Press [Enter] to make settings for the following sub-items:

SATA Configuration

SATA Controller

The optional settings: [Enabled]; [Disabled].

When set as [Enabled], user can make further settings in the following items:

SATA Speed Support

The optional settings: [Gen1]; [Gen2].

SATA Mode

The optional settings: [IDE Mode]; [AHCI Mode].

SATA Port

The optional settings: [Enabled]; [Disabled].

M.2

The optional settings: [Enabled]; [Disabled].

▶ **Network Stack Configuration**

Press [Enter] to go to '**Network Stack**' screen to make further settings.

Network Stack

Use this item to enable or disable UEFI Network Stack.

The optional settings: [Disabled]; [Enabled].

When set as [Enabled], the following sub-items shall appear:

Ipv4 PXE Support

Use this item to enable Ipv4 PXE Boot Support. When set as [Disabled], Ipv4 PXE boot option will not be created.

The optional settings: [Disabled]; [Enabled].

Ipv6 PXE Support

Use this item to enable Ipv6 PXE Boot Support. When set as [Disabled], Ipv6 boot optional will not be created.

The optional settings: [Disabled]; [Enabled].

PXE Boot Wait Time

Use this item to set wait time to press [ESC] key to abort the PXE boot. Use either +/- or numeric keys to set the value.

▶ **CSM Configuration**

Press [Enter] to make settings for the following sub-items:

Compatibility Support Module Configuration

Boot Option Filter

This item controls Legacy/UEFI ROMs priority.

The optional settings: [UEFI and Legacy]; [Legacy Only]; [UEFI Only].

Network

This item controls the execution of UEFI and Legacy PXE OpROM.

The optional settings: [Do Not Launch]; [UEFI Only]; [Legacy Only].

Storage

This item controls the execution of UEFI and Legacy Storage OpROM.

The optional settings: [Do Not Launch]; [UEFI Only]; [Legacy Only].

Other PCI devices

This item determines OpROM execution policy for devices other than Network, Storage or Video.

The optional settings: [UEFI First]; [Legacy Only].

▶ **Wake-up Function Settings**

Press [Enter] to make settings for the following sub-items:

Wake-up System with Fixed Time

Use this item to enable or disable System wake on alarm event.

The optional settings: [Disabled]; [Enabled].

When set as [Enabled], the following items shall appear:

Wake-up Hour

Use this item to select 0-23. For example enter 3 for 3am and 15 for 3pm.

Wake-up Minute

Use this item to select 0-59.

Wake-up Second

Use this item to select 0-59.

Wake-up System with Dynamic Time

Use this item to enable or disable System wake on alarm event.

System will wake on the current time + Increase minute(s).

The optional settings: [Disabled]; [Enabled].

When set as [Enabled], system will wake on the current time + increased minute(s).

Wake-up Minute Increase

Use this item to select 1 to 60 minute(s).

USB/PS2 Power Gating in S3-S5

Use this item to select 1 to 60 minute(s).

USB Wake-up is affected by ERP function in S4. Please disable ERP before activating this function in S4.

The optional settings: [Enabled]; [Disabled].

▶ **USB Configuration**

Press [Enter] to make settings for the following sub-items:

USB Configuration

USB Devices

Legacy USB Support

Use this item to enable Legacy USB support.

The optional settings: [Enabled]; [Disabled]; [Auto].

[Enabled]: To enable legacy USB support.

[Disabled]: To keep USB devices available only for EFI specification,

[Auto]: To disable legacy support if no USB devices are connected.

XHCI Hand-off

This is a workaround for OSeS without XHCI hand-off support. The XHCI ownership change should be claimed by XHCI driver.

The optional settings: [Enabled]; [Disabled].

EHCI Hand-off

This is a workaround for OSeS without EHCI hand-off support. The EHCI ownership change should be claimed by EHCI driver.

The optional settings: [Disabled]; [Enabled].

USB Mass Storage Driver Support

The optional settings: [Disabled]; [Enabled].

USB Hardware Delays and Time-outs:

USB Transfer Time-out

Use this item to set the time-out value for Control, Bulk, and Interrupt transfers.

The optional settings: [1 sec]; [5 sec]; [10 sec]; [20 sec].

Device Reset Time-out

Use this item to set USB mass storage device Start Unit command time-out.

The optional settings are: [10 sec]; [20 sec]; [30 sec]; [40 sec].

Device Power-up Delay

Use this item to set maximum time the device will take before it properly reports itself to the host controller.

The optional settings: [Auto]; [Manual].

'Auto' uses default value: for a Root port it is 100 ms, for a Hub port the delay is taken from Hub descriptor.

When set as [Manual] you can set value for the following sub-item: '**Device Power-up Delay in Seconds**'.

Device Power-up Delay in Seconds

The delay range is from [1] to [40] seconds, in one second increments.

- ▶ **Intel(R) I211 Gigabit Network Connection – XX: XX: XX: XX: XX: XX**

3-8 Chipset Menu



- ▶ **North Bridge**

Press [Enter] to view memory configurations or make settings for the following sub-items:

PAVC

Use this item to enable or disable Protected Audio Video Control.
The optional settings: [Disabled]; [LITE Mode]; [SERPENT Mode].

DVMT Pre-Allocated

Use this item to select DVMT 5.0 Pre-Allocated (Fixed) Graphics Memory size used by the Internal Graphics Device.

The optional settings: [64M]; [96M]; [128M]; [160M]; [192M]; [224M]; [256M]; [288M]; [320M]; [352M]; [384M]; [416M]; [448M]; [480M]; [512M].

DVMT Total Gfx Mem

Use this item to select DVMT 5.0 Total Graphics Memory size used by the Internal Graphics Device.

The optional settings: [128M]; [256M]; [Max].

Aperture Size

The optional settings: [128MB]; [256MB]; [512MB].

GTT Size

The optional settings: [1MB]; [2MB].

Primary IGFX Boot Display

Use this item to select the Video Device which will be activated during POST. This has no effect if external graphics present. Secondary boot display selection will appear based on your selection. VGA modes will be supported only on primary display.

The optional settings: [VBIOS Default]; [CRT]; [HDMI]; [LFP].

* **Note:** *User needs to set 'Active LFP' as [LVDS] or [eDP], otherwise the optional setting [LFP] will not be available.*

Active LFP

The optional settings: [Disabled]; [LVDS]; [eDP].

Backlight Control

The optional settings are: [PWM Inverted]; [PWM Normal].

Memory Information

Total Memory

▶ **South Bridge**

Press [Enter] for further settings in the following items:

PCIE Slot

The default settings is: [Enabled].

Speed

Use this item to configure PCIe Port Speed.

The optional settings: [Auto]; [Gen 2]; [Gen 1].

Onboard PCIE LAN

The optional settings: [Enabled]; [Disabled].

Audio Controller

Use this item to control detection of the Azalia device.

The optional settings: [Disabled]; [Enabled].

[Disabled]: Azalia will be unconditionally disabled;

[Enabled]: Azalia will be unconditionally enabled.

Azalia HDMI Codec

Use this item to enable or disable internal HDMI codec for Azalia.

The optional settings: [Disabled]; [Enabled].

▶ **USB Configuration**

Press [Enter] for further settings in the following items:

USB Configuration

USB 3.0 Support

Use this item to select mode of operation of xHCI controller.

The optional settings: [Enabled]; [Auto]; [Disabled].

When set as **[Auto]** or **[Disabled]**, user can make the USB 2.0 function.

USB 2.0 Support

Use this item to control the USB 2.0 functions.

The optional settings: [Enabled]; [Disabled].

System State after Power Failure

Use this item to select system state when AC power is re-applied after a power loss.

The optional settings: [Always Off]; [Always On]; [Former State].

***Note:** *The option [Always On] and [Former State] are affected by 'ERP Support' function. Please disable ERP to support [Always On] and [Former State] function.*

3-9 Security Menu

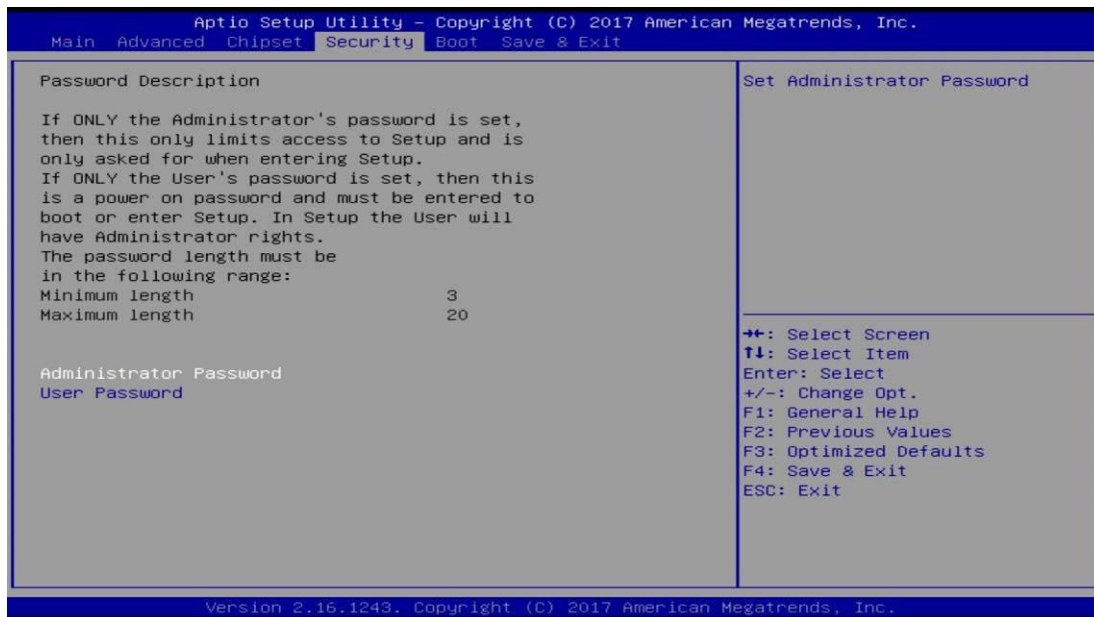

Security menu allow users to change administrator password and user password settings.

Administrator Password

If there is no password present on system, please press [Enter] to create new administrator password. If password is present on system, please press [Enter] to verify old password then to clear/change password. Press again to confirm the new administrator password.

User Password

If there is no password present on system, please press [Enter] to create new user password. If password is present on system, please press [Enter] to verify old password then to clear/change password. Press again to confirm the new user password.

3-10 Boot Menu

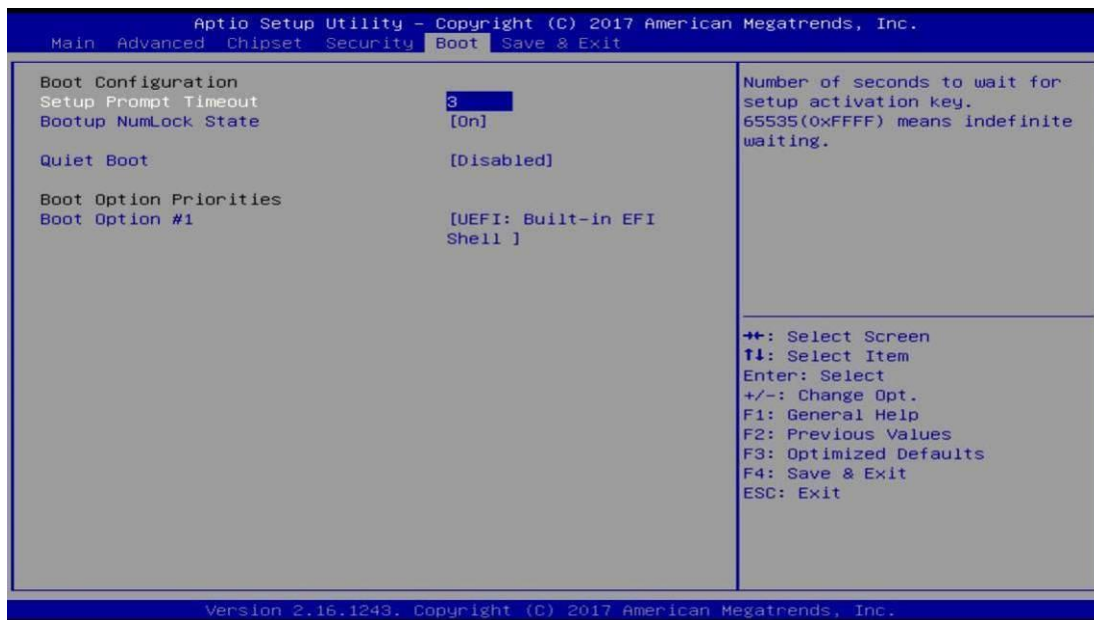

Boot Configuration

Setup Prompt Timeout

Use this item to set number of seconds to wait for setup activation key. 65535(0xFFFF) means indefinite waiting.

Bootup NumLock State

Use this item to select the keyboard NumLock state. The optional settings: [On]; [Off].

Quiet Boot

The optional settings: [Disabled]; [Enabled].

Boot Option Priorities

Boot Option #1

Use this item to decide system boot order from available options.

The optional settings: [UEFI: Built-in EFI Shell]; [Disabled].

3-11 Save & Exit Menu

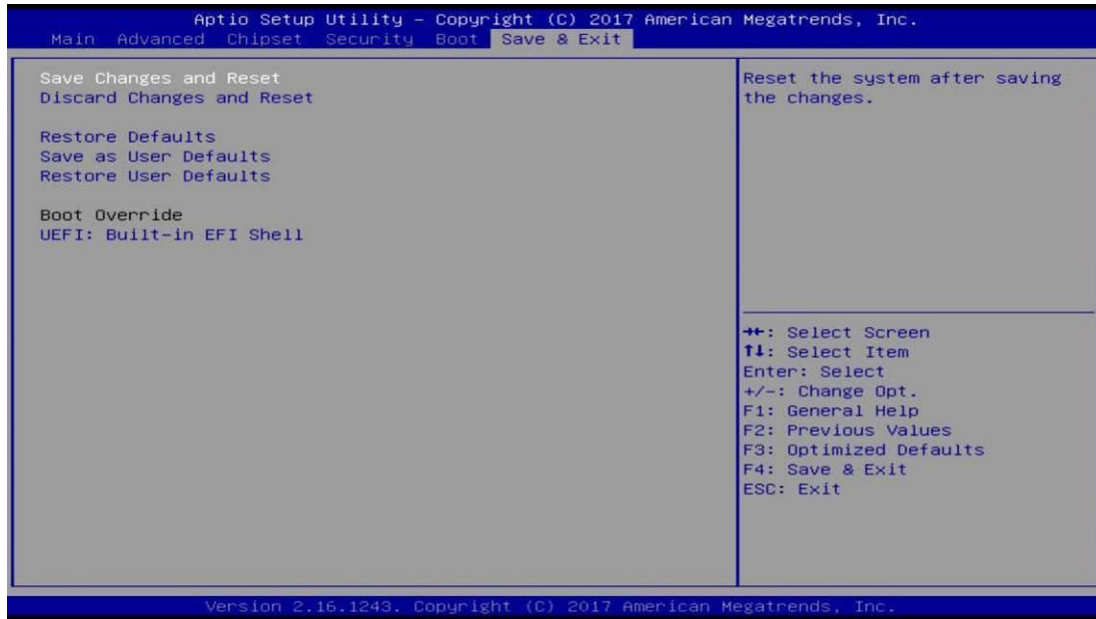

Save Changes and Reset

This item allows user to reset the system after saving the changes.

Discard Changes and Reset

This item allows user to reset the system without saving any changes.

Restore Defaults

Use this item to restore /load default values for all the setup options.

Save as User Defaults

Use this item to save the changes done so far as user defaults.

Restore User Defaults

Use this item to restore the user defaults to all the setup options.

Boot Override

UEFI: Built-in EFI Shell

Use this item to save configuration and reset.