

MM21 Series User's Manual

No. G03-MM21-F

Rev: 1.0

Release date: September 29, 2022

Trademark:

* Specifications and Information contained in this documentation are furnished for information use only, and are subject to change at any time without notice, and should not be construed as a commitment by manufacturer.

TABLE OF CONTENT

ENVIRONMENTAL SAFETY INSTRUCTION	iii
ENVIRONMENTAL PROTECTION ANNOUCEMENT	iii
USER'S NOTICE	iv
MANUAL REVISION INFORMATION	iv
ITEM CHECKLIST	iv
CHAPTER 1 INTRODUCTION OF THE MOTHERBOARD	
1-1 SPECIFICATION	1
1-2 LAYOUT DIAGRAM	2
CHAPTER 2 HARDWARE INSTALLATION	
2-1 JUMPER SETTING.....	7
2-2 CONNECTORS AND HEADERS	9
2-2-1 REAR I/O BACK PANEL CONNECTORS	9
2-2-2 MOTHERBOARD INTERNAL CONNECTORS	11
2-2-3 HEADER PIN DEFINITION	15
2-2-4 Maximum Voltage & Current Limit	18
CHAPTER 3 INTRODUCING BIOS	
3-1 ENTERNING SETUP	19
3-2 BIOS MENU SCREEN	20
3-3 FUNCTION KEYS	20
3-4 GETTING HELP.....	20
3-5 MENU BARS	21
3-6 MAIN MENU	21
3-7 ADVANCED MENU	22
3-8 CHIPSET MENU	33
3-9 SECURITY MENU	35
3-10 BOOT MENU	37
3-11 SAVE & EXIT MENU	38



Environmental Safety Instruction

- Avoid the dusty, humidity and temperature extremes. Do not place the product in any area where it may become wet.
- 0 to 40 centigrade is the suitable temperature. (The figure comes from the request of the main chipset)
- Generally speaking, dramatic changes in temperature may lead to contact malfunction and crackles due to constant thermal expansion and contraction from the welding spots' that connect components and PCB. Computer should go through an adaptive phase before it boots when it is moved from a cold environment to a warmer one to avoid condensation phenomenon. These water drops attached on PCB or the surface of the components can bring about phenomena as minor as computer instability resulted from corrosion and oxidation from components and PCB or as major as short circuit that can burn the components. Suggest starting the computer until the temperature goes up.
- The increasing temperature of the capacitor may decrease the life of computer. Using the close case may decrease the life of other device because the higher temperature in the inner of the case.
- Attention to the heat sink when you over-clocking. The higher temperature may decrease the life of the device and burned the capacitor.

Environmental Protection Announcement

Do not dispose this electronic device into the trash while discarding. To minimize pollution and ensure environment protection of mother earth, please recycle.



USER'S NOTICE

COPYRIGHT OF THIS MANUAL BELONGS TO THE MANUFACTURER. NO PART OF THIS MANUAL, INCLUDING THE PRODUCTS AND SOFTWARE DESCRIBED IN IT MAY BE REPRODUCED, TRANSMITTED OR TRANSLATED INTO ANY LANGUAGE IN ANY FORM OR BY ANY MEANS WITHOUT WRITTEN PERMISSION OF THE MANUFACTURER.

THIS MANUAL CONTAINS ALL INFORMATION REQUIRED TO USE THIS MOTHER-BOARD SERIES AND WE DO ASSURE THIS MANUAL MEETS USER'S REQUIREMENT BUT WILL CHANGE, CORRECT ANY TIME WITHOUT NOTICE. MANUFACTURER PROVIDES THIS MANUAL "AS IS" WITHOUT WARRANTY OF ANY KIND, AND WILL NOT BE LIABLE FOR ANY INDIRECT, SPECIAL, INCIDENTAL OR CONSEQUENTIAL DAMAGES (INCLUDING DAMAGES FOR LOSS OF PROFIT, LOSS OF BUSINESS, LOSS OF USE OF DATA, INTERRUPTION OF BUSINESS AND THE LIKE).

PRODUCTS AND CORPORATE NAMES APPEARING IN THIS MANUAL MAY OR MAY NOT BE REGISTERED TRADEMARKS OR COPYRIGHTS OF THEIR RESPECTIVE COMPANIES, AND THEY ARE USED ONLY FOR IDENTIFICATION OR EXPLANATION AND TO THE OWNER'S BENEFIT, WITHOUT INTENT TO INFRINGE.

Manual Revision Information

Reversion	Revision History	Date
1.0	First Edition	September 29, 2022

Item Checklist

- Motherboard
- Cable(s)
- I/O Back panel shield

Chapter 1

Introduction of the Motherboard

1-1 Specification

Spec	Description
Design	<ul style="list-style-type: none"> ● Micro ATX form factor; PCB size: 24.4 x24.4 cm
Chipset	<ul style="list-style-type: none"> ● MM21-Q4700/Q4702 Series: Intel Q470E Chipset ● MM21-W4800/W4802 Series: Intel W480E Chipset
CPU Socket	<ul style="list-style-type: none"> ● Intel LGA 1200 Socket supports 10th/11th Gen. Processor (Max. 95W TDP) <p><i>* Note: for detailed CPU support information please visit our website</i></p>
Memory Slots	<ul style="list-style-type: none"> ● 4* Long DIMM DDR4 slot for 4* DDR4 3200/2933/2666/2400MHz RAM Module ● Support dual channel function <p><i>Maximum capacity: up to 128GB</i> <i>Maximum frequency: 3200 MHz (depends on CPU support)</i></p> <p><i>*Note: MM21-W4800/W4802 series supports DDR4 ECC SDRAM</i></p>
Expansion Slots	<ul style="list-style-type: none"> ● 1* PCI-Express x1 slot (PCIE1) ● 1* PCI-Express x16 slot (*PCIE2) ● 1* PCI-Express x4 slot (PCIE3) ● 1* PCI-Express x8 slot (*PCIE4) <p><i>*Note: PCIE2 slot share x16 lane band width with PCIE4 slot.</i></p> <ul style="list-style-type: none"> ● 1* M.2 E-key slot, type-2230 PCIe1/USB2.0 interface support CNVi (M2E1)
Storage	<ul style="list-style-type: none"> ● MM21-Q4700/Q4702 Series: 6* SATAIII 6Gb/s port support RAID 0/1/5/10 (SATA_RA1/2/3) ● MM21-W4800/W4802 Series: 8* SATAIII 6Gb/s port support RAID 0/1/5/10 (SATA_RA1/2/3;SATA7/8) ● 1* M.2 M-key slot, type-2242/2260/2280/22110 PCIe4 interface supports NVMe (M2M1) ● 1* M.2 M-key slot, type-2260/2280 PCIe2 interface (M2M2)
LAN Chips	<ul style="list-style-type: none"> ● 1* Intel i219-LM 1.0GbE & 1* Intel i210-AT 1.0GbE ● 2* Intel i225-V 2.5GbE (For MM21-Q4700/Q4702) ● 2* Intel i225-LM 2.5GbE (For MM21-W4800/W4802) <p><i>Note: 2500Mbps high-speed transmission rate is only supported over CAT 5e UTP cable.</i></p>
BIOS	<ul style="list-style-type: none"> ● AMI Flash ROM BIOS
Multi I/O	<p>Rear Panel I/O:</p> <ul style="list-style-type: none"> ● 2* RS232/422/485 COM ports ● 2* HDMI 1.4 ports ● 2* 2.5GbE RJ-45 LAN ports ● 2* 1.0GbE RJ-45 LAN ports ● 4* USB 3.2(Gen.2) ports <p>Internal I/O Connectors & Headers:</p> <ul style="list-style-type: none"> ● 1* 24-pin main power connector ● 1* 8-pin 12V power connector

	<ul style="list-style-type: none"> ● 1* CUFAN connector & 6* SYSFAN connector ● 1* Front panel header ● 2* 9-Pin USB 2.0 headers for 4* USB 2.0 expansion ports ● 1* 19-Pin USB 3.2(Gen.1) header for 2* USB 3.2(Gen.1) ports ● 1* 8-bit GPIO header ● 1* PS/2 Keyboard & Mouse header ● 1* SMBUS header ● 4* RS232 COM port headers <p>(Optional for MM21-Q4700/Q4702 series only)</p>
TPM 2.0 Function	<ul style="list-style-type: none"> ● Optional for MM21-Q4702 & MM21-W4802 Series

1-2 Layout Diagram

Rear IO Diagram

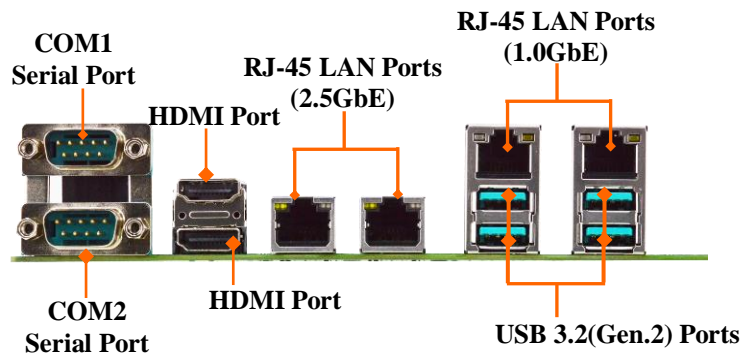

***Note:** **COM1-2** for **MM21-Q4700/Q4702** Series support RS232/422/485 function;
COM1-2 for **MM21-W4800/W4802** Series support RS232 function only.

Motherboard Internal Diagram

MM21-Q4700/Q4702 Series:

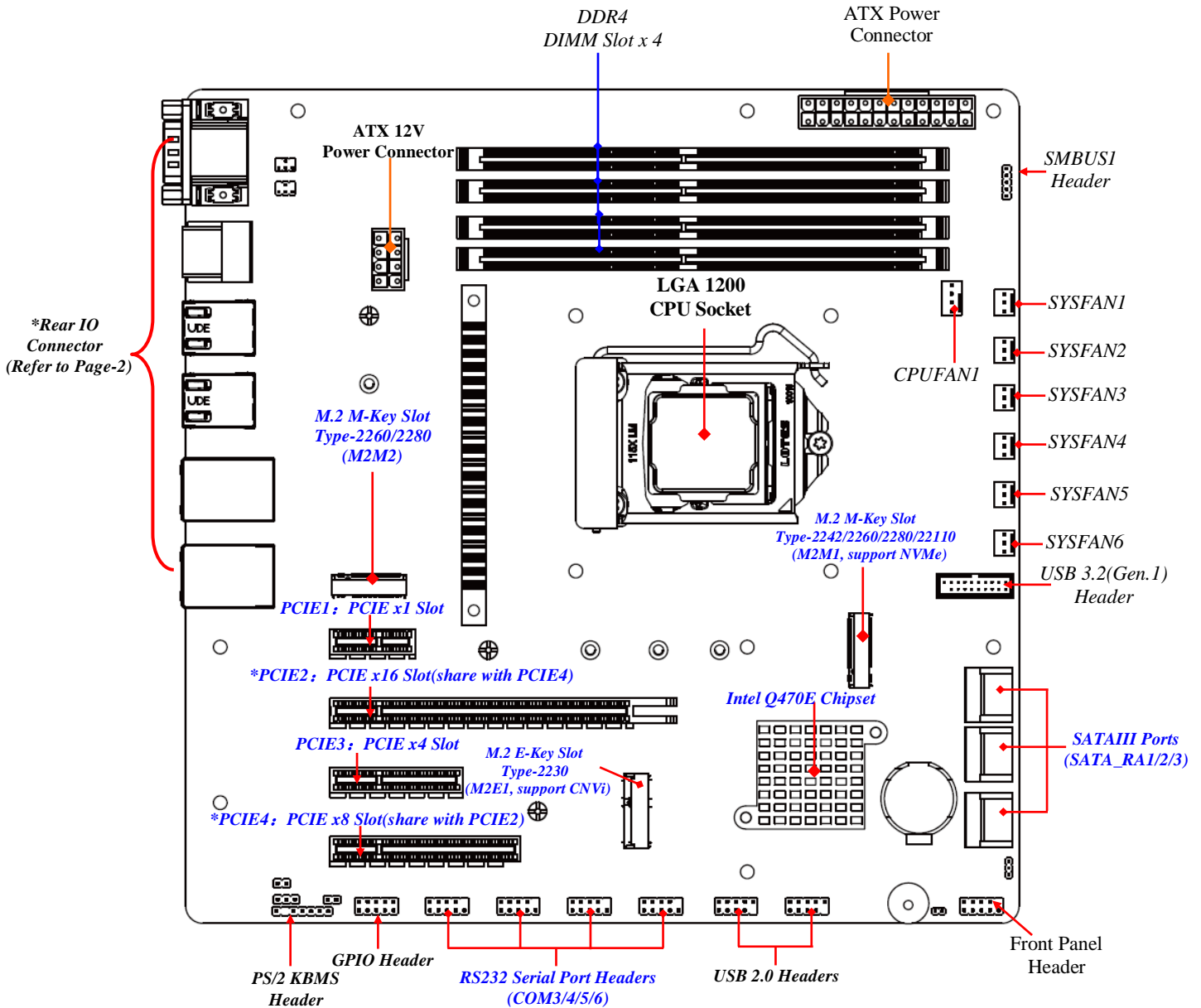

***Note:** PCIE4 slot share x16 lane band width with PCIE2 slot. Configuration solutions: 1* PCIE x16 card, please plug in PCIE2 slot to run at x16 (Max.) lane band width; in the case that 2* PCIE cards plugged in PCIE2 & PCIE4 slots, since the 2* PCIE slots share x16 lane band width, each card will run at x8 (Max.) lane band width.

MM21-W4800/W4802 Series:

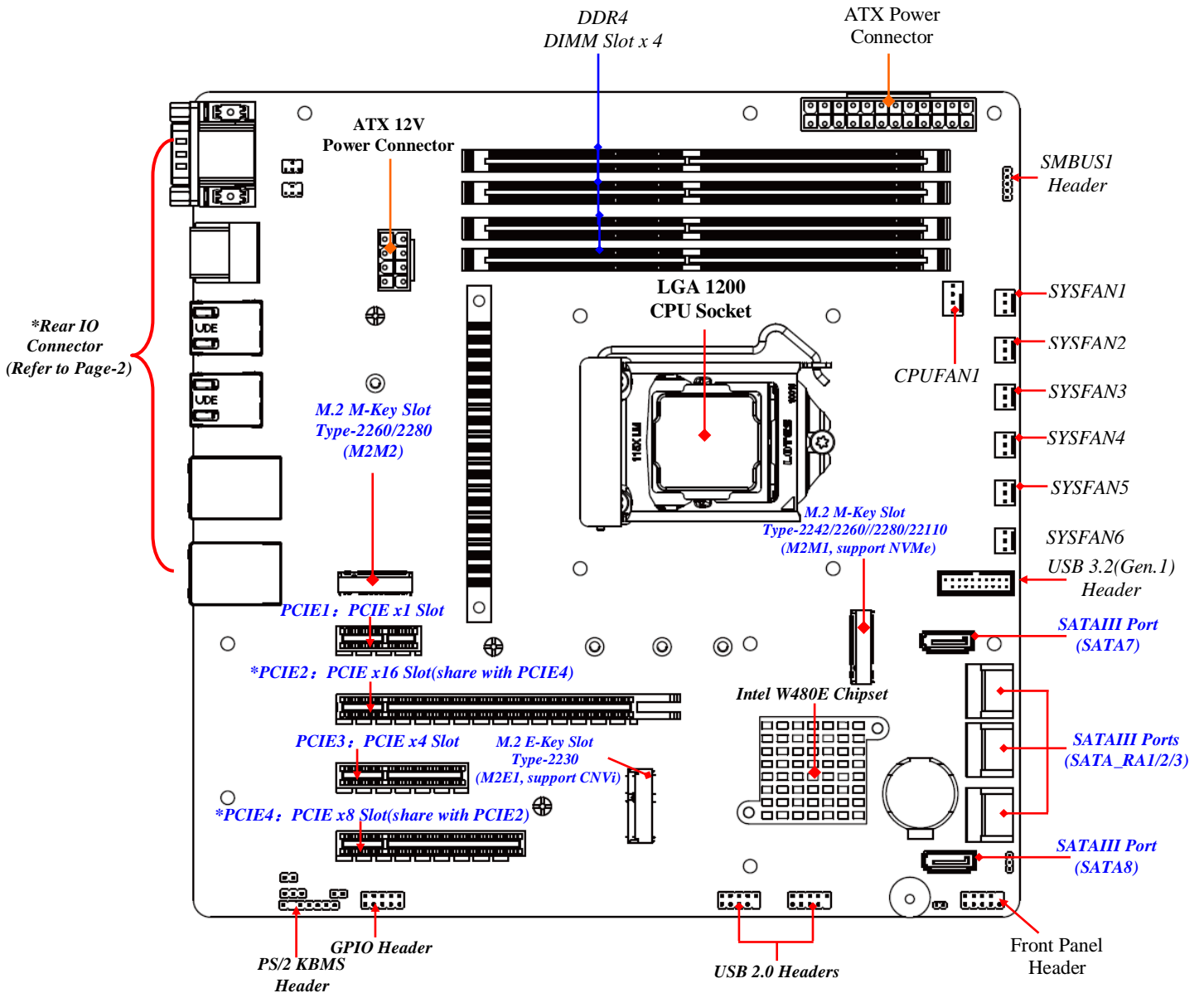

***Note:** 1.PCIE4 slot share x16 lane band width with PCIE2 slot. **Configuration solutions:** 1* PCIE x16 card, please plug in PCIE2 slot to run at x16 (Max.) lane band width; in the case that 2* PCIE cards plugged in PCIE2 & PCIE4 slots, since the 2* PCIE slots share x16 lane band width, each card will run at x8 (Max.) lane band width.

Motherboard Jumper Position:

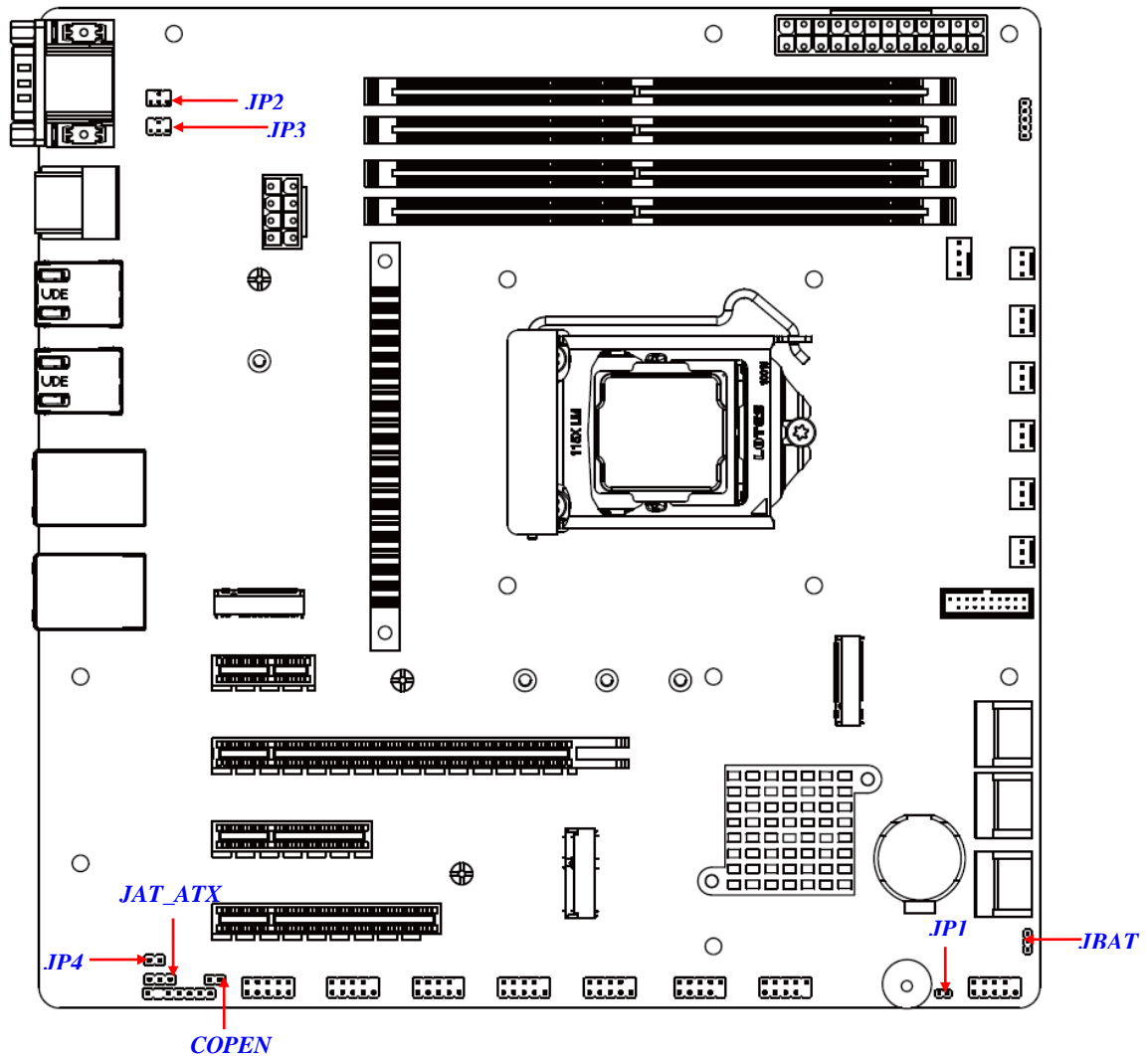

**Note: The diagrams in the manual are mostly taken from MM21-Q4700/Q4702 series unless otherwise stated.*

Jumper

Jumper	Name	Description	Pitch
JBAT	Clear CMOS RAM Settings	3-pin Block	2.0mm
JAT_ATX	ATX/AT Mode Select	3-pin Block	2.54mm
COPEN	Case Open Message Display Detect	2-pin Block	2.54mm
JP1	ME Features Select	2-pin Block	2.0mm
JP2	COM1 Port Pin9 Function Select	4-pin Block	2.0mm
JP3	COM2 Port Pin9 Function Select	4-pin Block	2.0mm
JP4	PCIe x16 & PCIe x8 Function Select	2-pin Block	2.0mm

Connectors

Connector	Name
COM1-2	Serial Port X2
HDMI1-2	HDMI 1.4 Port X2 (Max Resolution: 4096x2160@30Hz)
LAN3/LAN4	2.5GbE RJ-45 LAN Port X2
UL1/UL2	Top: 1.0GbE RJ-45 LAN Port X2 Middle & Bottom: USB 3.2(Gen.2) Port X4
ATXPWR1	ATX Type Main Power Connector
ATX12V1	ATX 12V Power Connector
CPUFAN1	CPU FAN Connector
SYSFAN1/2/3/4/5/6	System FAN Connector X6
SATA_RA1/2/3	SATAIII Connector X6
*SATA7/SATA8	SATAIII Connector X2

***Note:** SATA7 & SATA8 ports are only optional for MM21-W4800/W4802 series.

Headers

Header	Name	Description	Pitch
FP (Front Panel Header)	PWR LED/ HD LED/ Power Button /Reset	9-pin Block	2.54mm
FP_USB2/FP_USB3	USB 2.0 Port Header X2	9-pin Block	2.54mm
FP_USB1	USB 3.2(Gen.1) Port Header	19-pin Block	2.0mm
*COM3/4/5/6	RS232 Serial Port Header X4	9-pin Block	2.54mm
GPIO	GPIO Header	10-pin Block	2.54mm
PS2KBMS	PS/2 Keyboards & Mouse Header	6-pin Block	2.54mm
SMBUS1	SMBUS Header	5-pin Block	2.0mm

***Note:** COM3/4/5/6 ports are only optional for MM21-Q4700/Q4702 series.

Chapter 2

Hardware Installation

2-1 Jumper Setting

JBAT (3-pin): Clear CMOS RAM Settings Pitch=2.0mm

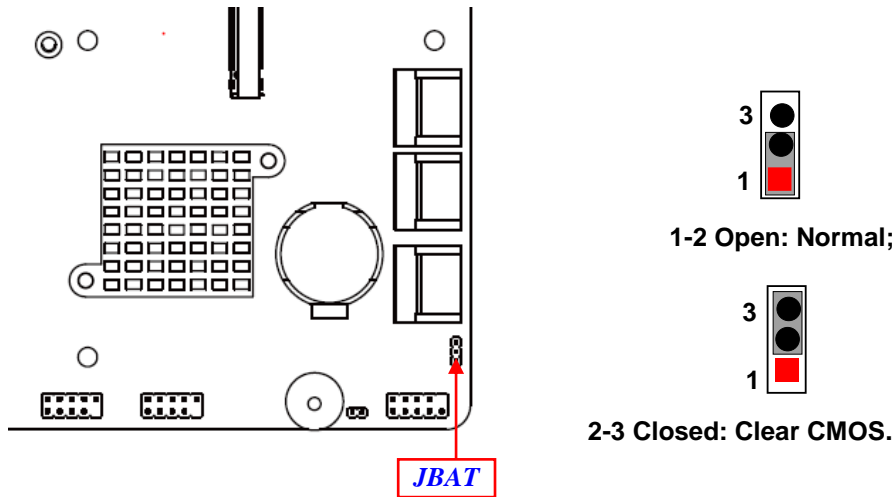

JAT_ATX (3-pin): AT Mode /ATX Mode Select Pitch=2.54mm

JAT_ATX → ATX/AT Mode Select

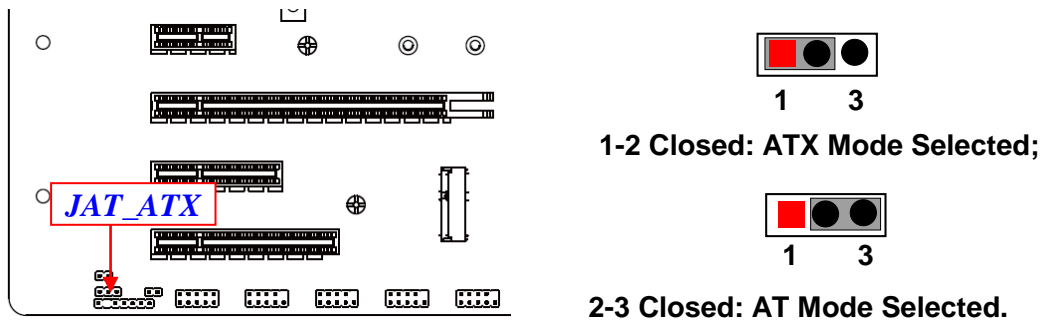

***ATX Mode Selected:** Press power button to power on after power input ready;
AT Mode Selected: Directly power on as power input ready.

COPEN (2-pin): Case Open Message Display Function Pitch=2.54mm

COPEN → Case Open Detection

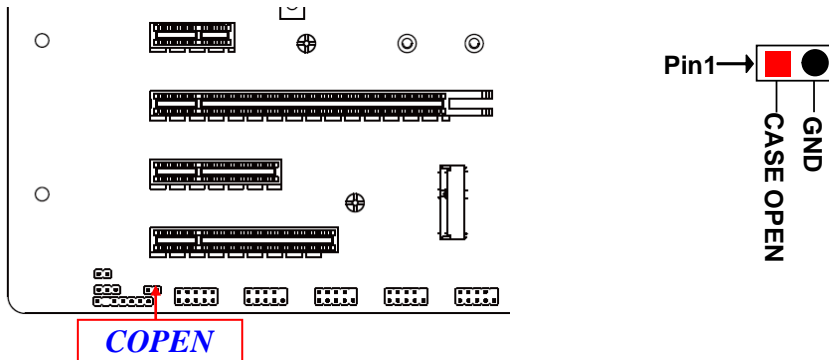

Pin 1-2 Short: When Case open function pin short to GND, the Case open function was detected. When Used, needs to enter BIOS and enable 'Case Open Detect' function. In this case if your case is removed, next time when you restart your computer, a message will be displayed on screen to inform you of this.

JP2 (4-pin): COM1 Port Pin9 Function Select Pitch=2.0mm

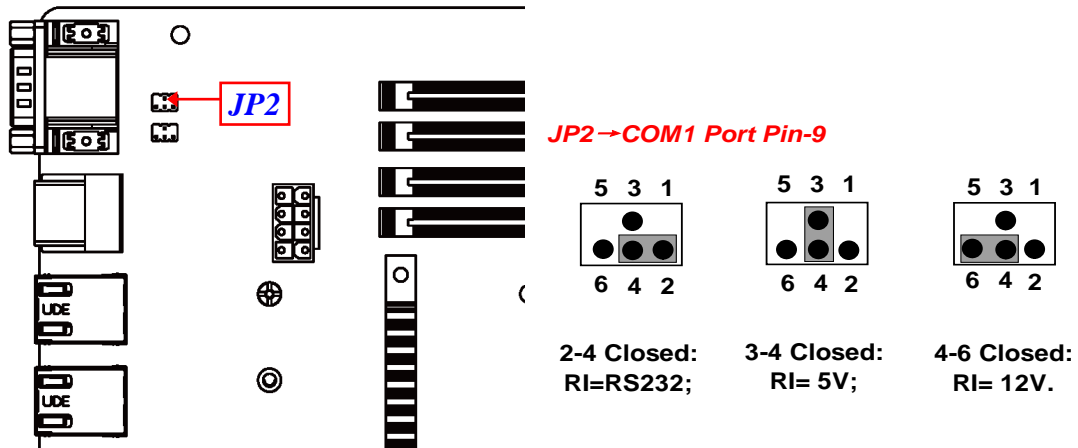

JP3 (4-pin): COM2 Port Pin9 Function Select Pitch=2.0mm

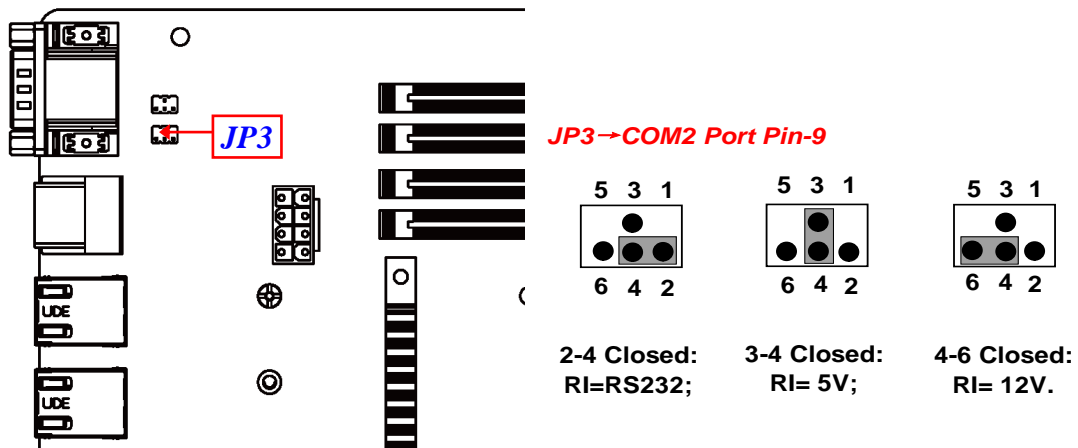

JP1 (2-pin): ME Features Select Pitch=2.0mm

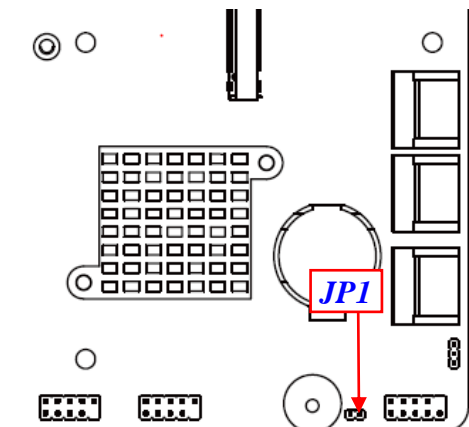

JP1 → ME Features Select

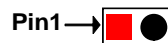

1-2 Open: Enable ME Features(Default);

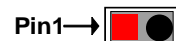

1-2 Closed: Disable ME Features.

JP4 (2-pin): PCIe x16 & Dual PCIe x8 Function Select Pitch=2.0mm

JP4 → PCIe x16 & Dual PCIe x8 Function Select

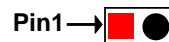
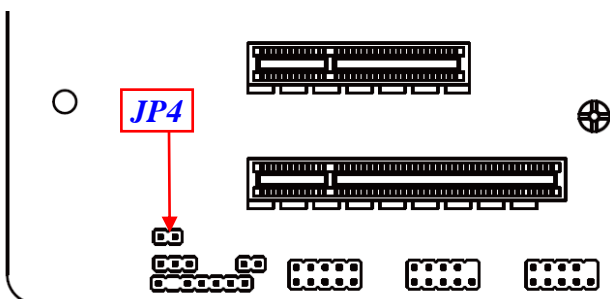

1-2 Open: PCIe x16 Select (Default);

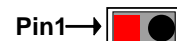





1-2 Closed: Dual PCIe x8 Select.

2-2 Connectors and Headers

2-2-1 Rear I/O Back Panel Connectors

**Refer to Page-2 Rear IO Diagram*

Icon	Name	Function
	Serial Port	Mainly for user to connect external MODEM or other devices that supports Serial Communications Interface. For MM21-Q4700/Q4702: RS232/422/485 For MM21-W4800/W4802: RS232
	HDMI 1.4 Port	To connect display device that support HDMI specification.
	RJ-45 LAN Port	This connector is standard RJ-45 LAN jack for Network connection. LAN3 & LAN4 port support 2.5GbE transfer rate. (*Note: 2.5Gbps is only supported with CAT 5e UTP cable.)

	RJ-45 LAN Port	This connector is standard RJ-45 LAN jack for Network connection. These two RJ-45 LAN port from UL1 and UL2 support 1.0GbE transfer rate.
	USB 3.2(Gen.2) Port	To connect USB keyboard, mouse or other devices compatible with USB 3.2(Gen.2) specification. Ports support up to 10Gbps data transfer rate.

***Note:** Maximum current limit for USB ports from **UL1/UL2** is **1.5A** while using **5V** working voltage.

COM1-2 (9-pin Block): Serial Port

***Note:** **COM1-2** for **MM21-Q4700/Q4702** Series support **RS232/422/485** function; **COM1-2** for **MM21-W4800/W4802** Series support **RS232** function only.

The pin assignment for RS232/422/485 is listed as follows:

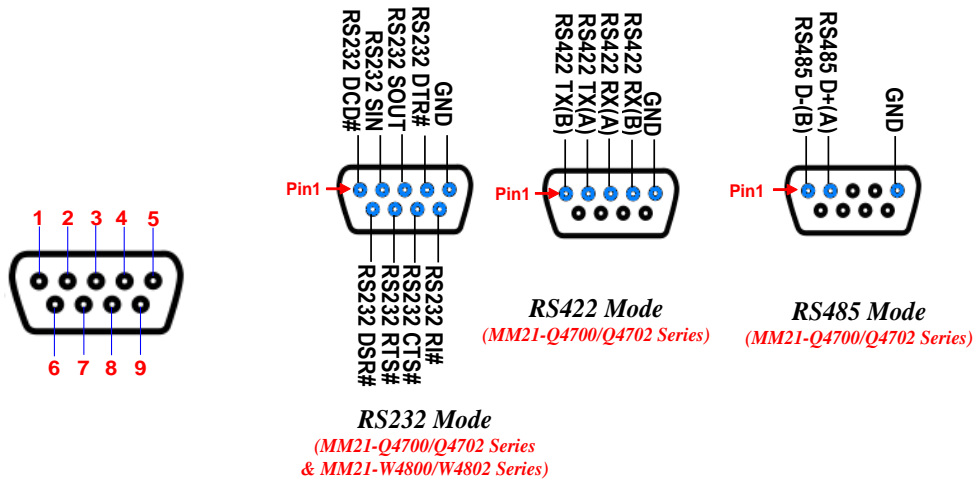

For **MM21-Q4700/Q4702** series, **COM1** & **COM2** port can function as RS232/422/485 port. In default settings COM1/2 functions as RS232 port. With compatible COM cable COM1 can function as RS422 or RS485 port. User also needs to go to BIOS to set '**Transmission Mode Select**' for COM1/2 at first, before using specialized cable to connect different pins of this port.

2-2-2 Motherboard Internal Connectors

(1) ATXPWR1 (24-pin block): Main Power Connector

ATX Power Supply connector: This is a new defined 24-pins connector that usually comes with ATX case. The ATX Power Supply allows using soft power on momentary switch that connect from the front panel switch to 2-pins Power On jumper pole on the motherboard. When the power switch on the back of the ATX power supply turned on, the full power will not come into the system board until the front panel switch is momentarily pressed. Press this switch again will turn off the power to the system board.

** We recommend that you use an ATX 12V Specification 2.0-compliant power supply unit (PSU) with a minimum of 350W power rating. This type has 24-pin and 4-pin power plugs.

** If you intend to use a PSU with 20-pin and 4-pin power plugs, make sure that the 20-pin power plug can provide at least 15A on +12V and the power supply unit has a minimum power rating of 350W. The system may become unstable or may not boot up if the power is inadequate.

** If you are using a 20-pin power plug, please refer to Figure1 for power supply connection. Power plug form power supply and power connectors from motherboard both adopt key design to avoid mistake installation. You can insert the power plug into the connector with ease only in the right direction. If the direction is wrong it is hard to fit in and if you make the connection by force it is possible.

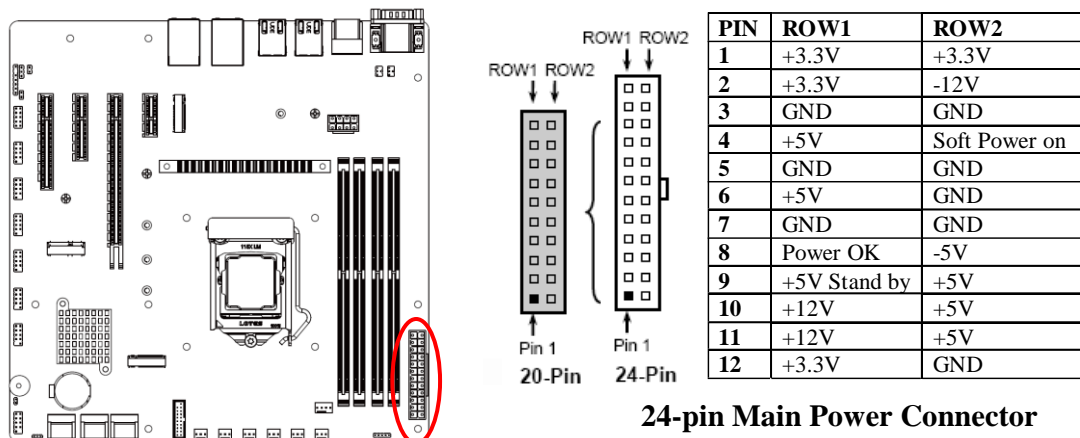

24-pin Main Power Connector

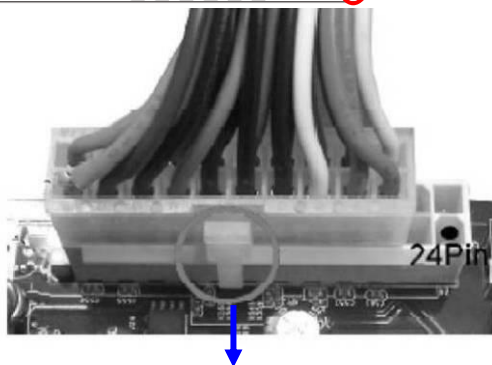

Figure1: 20-pin power plug

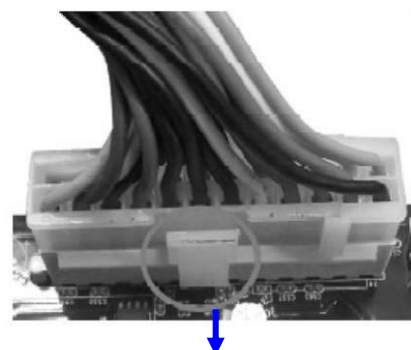
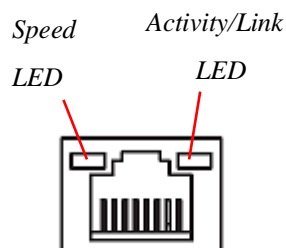

Figure 2: 24-pin power plug

(2) LAN1/LAN2 (1.0GbE) RJ-45 LAN Port

** There are two LED next to the LAN port. Please refer to the table below for the LAN port LED indications



A: Speed LED	
Status	Description
Off	10Mbps Connection
Green	100Mbps Connection
Orange	1Gbps Connection

B: Activity/Link LED	
Status	Description
Off	No Link
Blinking	Data Activity
On	Link

(3) LAN3/LAN4 (2.5GbE) RJ-45 LAN Port

** There are two LED next to the LAN port. Please refer to the table below for the LAN port LED indications

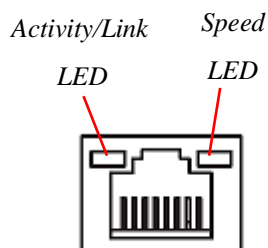

A: Activity/Link LED	
Status	Description
Off	No Link
Blinking	Data Activity
On	Link

B: Speed LED	
Off	10/100Mbps Connection
Green	1Gbps Connection
Orange	2.5Gbps Connection

Note: 2500Mbps high-speed transmission rate is **only** supported over **CAT 5e UTP cable**

(4) ATX12V1 (8-pin block): 12V Power Connector

This is a new defined 8-pin connector that usually comes with ATX Power Supply that supports extra 12V voltage to maintain system power consumption. Without this connector might cause system unstable because the power supply cannot provide sufficient current for system.

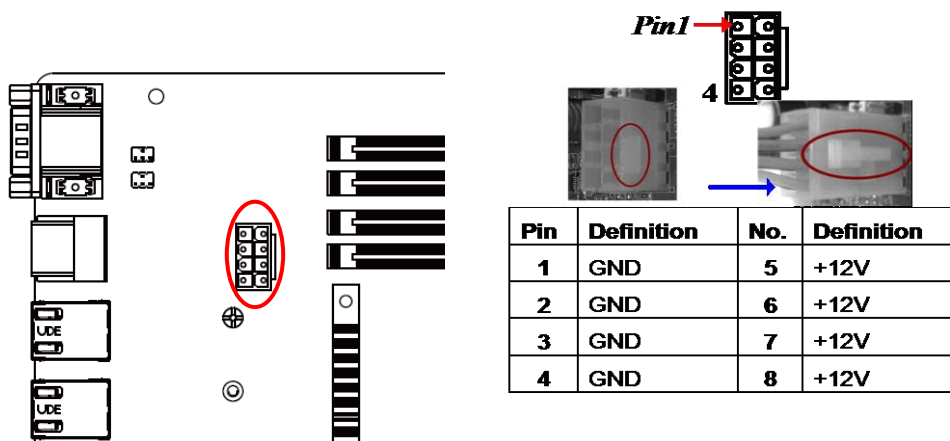

(5) CPUFAN1 (4-pin): CPU Fan Connector

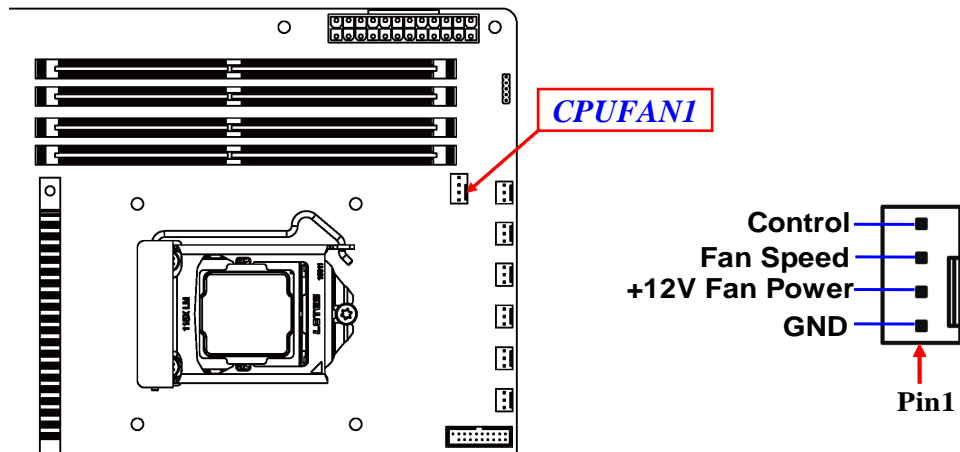

(6) SYSFAN1/2/3/4/5/6 (3-pin): System Fan Connectors

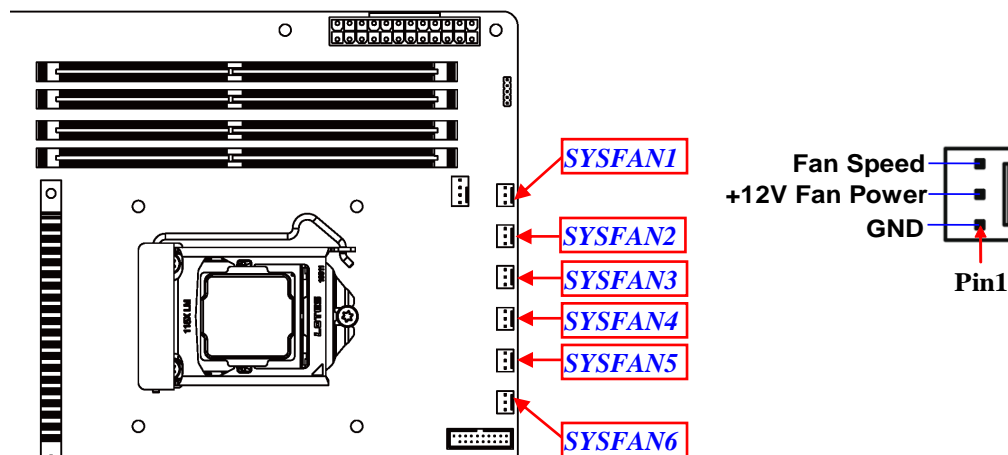

(7) SATA_RA1/2/3 & SATA7/8*(7-pin): SATAIII Port connector

These are high-speed SATAIII ports that support 6GB/s transfer rate.

*SATA7 & SATA8 is only optional for MM21-W4800/W4802 series.

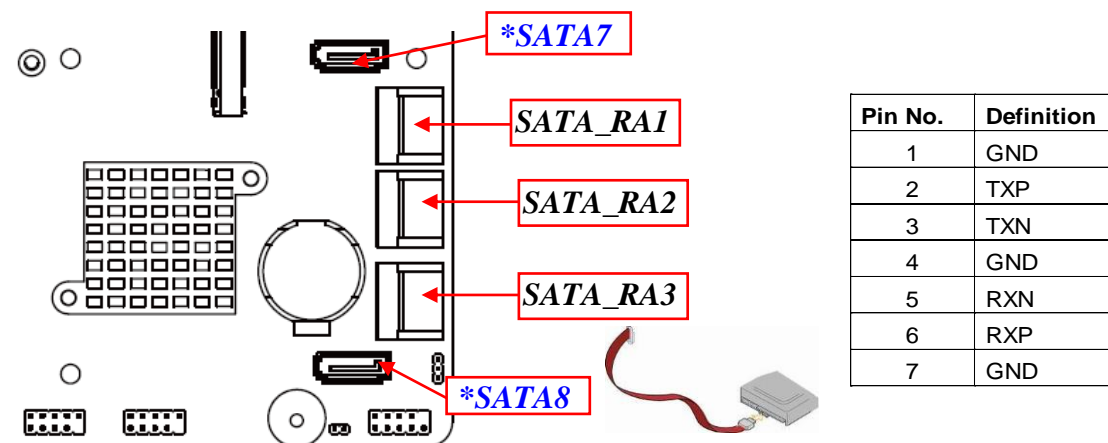

(8) M2M1 & M2M2 Slot: M.2 M-Key Slot

M2M1 M.2 M-Key slot supports compatible type-2242/2260/2280/22110 PCIe x4 SSD modules.

M2M2 M.2 M-Key slot supports compatible type-2260/2280 PCIe x2 SSD modules.

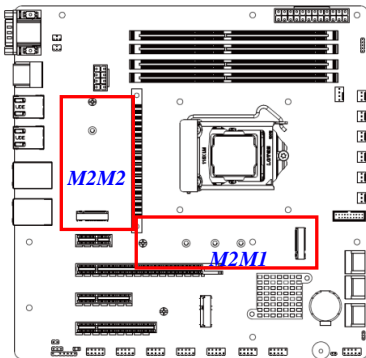

M2M1 Slot:



***Note:** the manual takes **M2M1** as an example for installation illustration; **M2M2** follows basically the same installation steps.

Z

M2M1 Slot Installation Guide:



1. Prepare compatible M.2 SSD card. Different type of cards has different length. Find corresponding nut location for further installation.

Nut Location	MH1	MH2	MH3	MH4
Card Length	4.2 cm	6cm	8 cm	11 cm
Module Type	Type- 2242	Type-2260	Type- 2280	Type- 22110

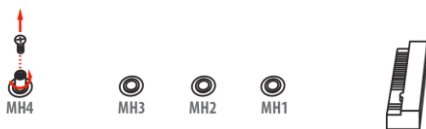

2. Remove the screw post and nut fixed at location **MH4** by default (Skip step 2 & 3 and go straight to Step 4 if you are going to use the default nut).



3. Lock the screw post into the location corresponding to the length of the module.



4. Align and insert corresponding M.2 module, as the photo shows.

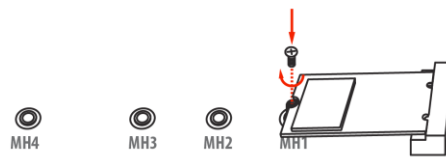

5. Tighten up the screw to secure the module into the M.2 connector. Make sure not over tighten the screw to avoid possible damage to the module.

(9) Dual Channel Memory Installation:

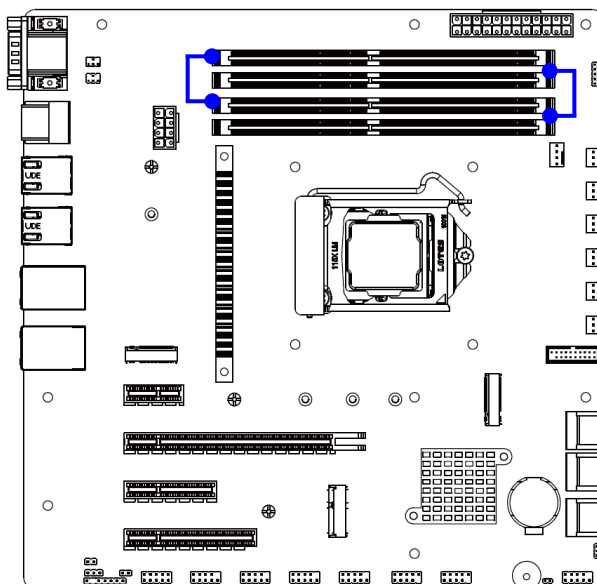

Configuration	DIMM1	DIMM2	DIMM3	DIMM4
1	install	--	install	--
2	--	install	--	install
3	install	install	install	install

Notice!

- For dual channel installation, you need to install the same brand, speed, size and type memory module.
- It is unable to activate dual channel feature if you install one or three memory modules, or you install DIMM1 & DIMM4 / DIMM2 & DIMM3. Slot order can be from left-to-right or right-to-left, and it must be installed in pairs.
- If you install memory modules in wrong direction, it will damage the motherboard and memory module.

2-2-3 Header Pin Definition

(1) FP (9-pin): Front Panel Header Pitch=2.54mm

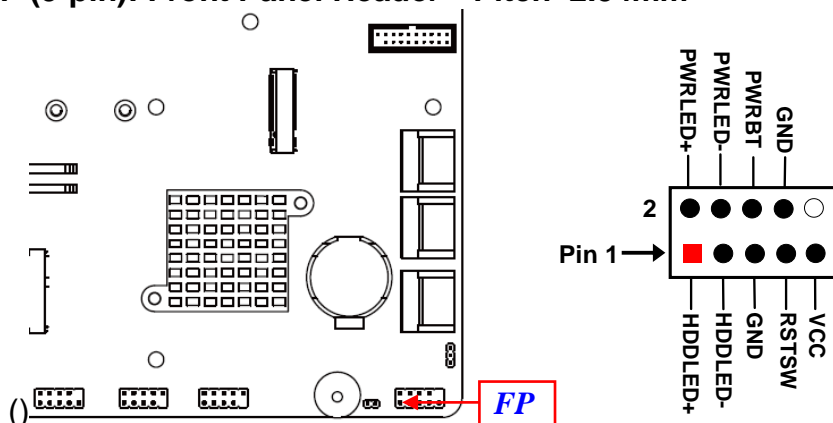

(2) FP_USB2/FP_USB3 (9-pin): USB 2.0 Port Headers Pitch=2.54mm

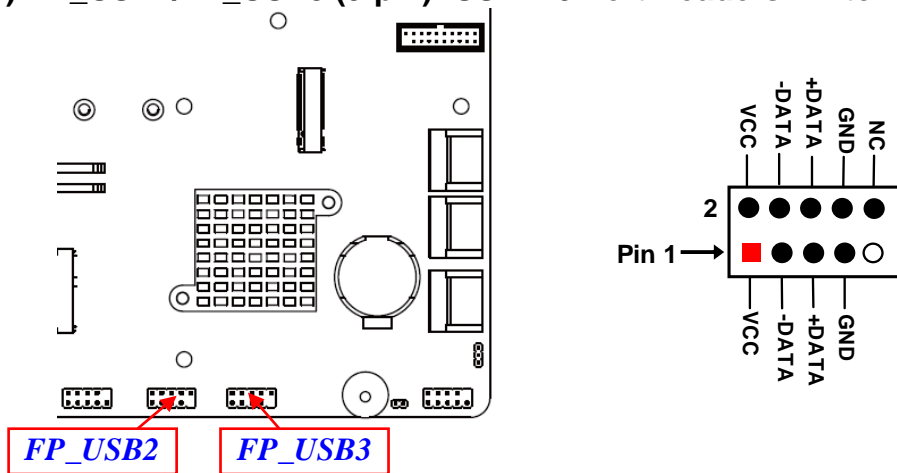

(3) FP_USB1 (19-pin): USB 3.2(Gen.1) Port Header Pitch=2.0mm

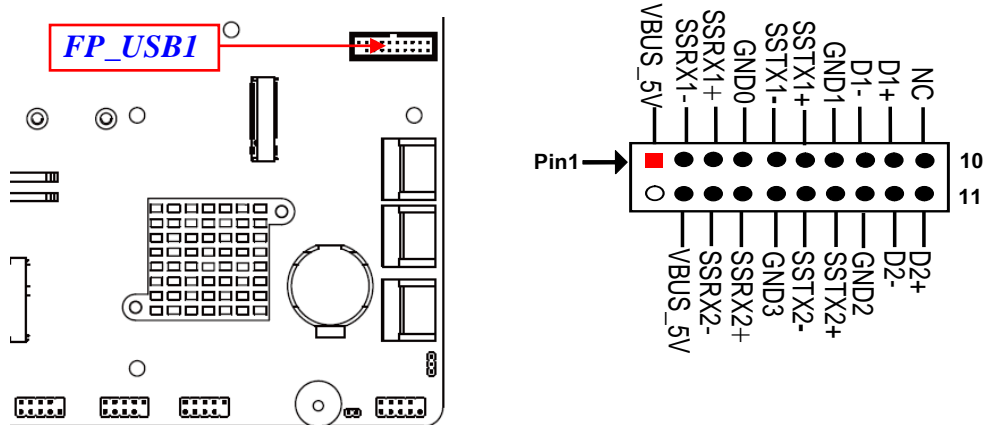

(4) COM3/4/5/6 (9-pin): RS232 Serial Port Header Pitch=2.54mm

***Note:** COM3/4/5/6 ports are optional for MM21-W4800/W4802 Series.

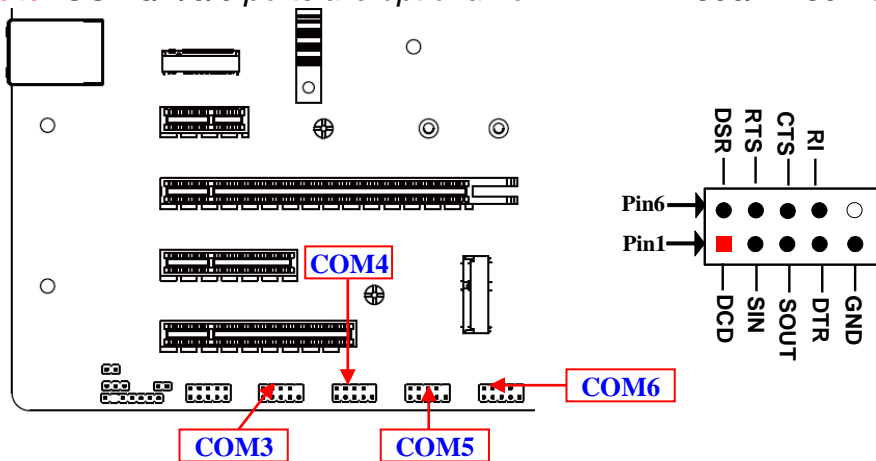

(5) GPIO (10-pin): GPIO Port Header Pitch=2.54mm

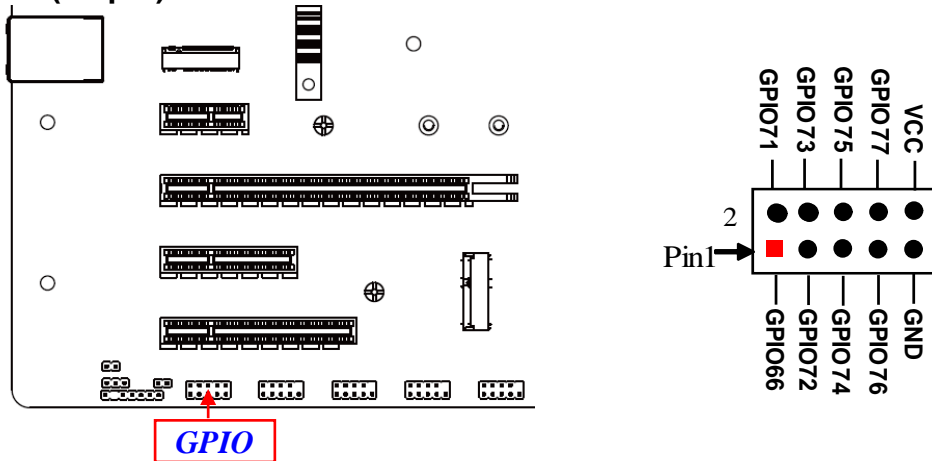

(6) PS2KBMS (6-pin): PS/2 Keyboard & Mouse Header Pitch=2.54mm

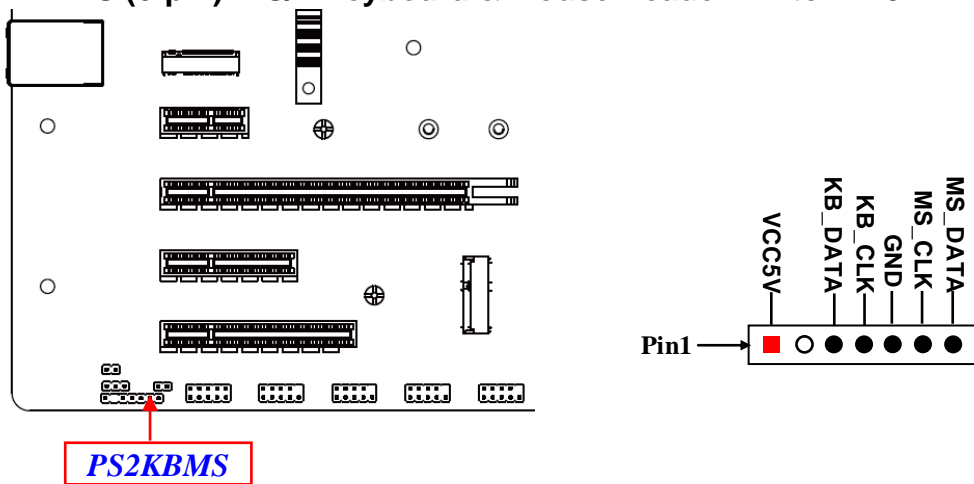

(7) SMBUS1 (5-Pin): SMBUS Header Pitch=2.0mm

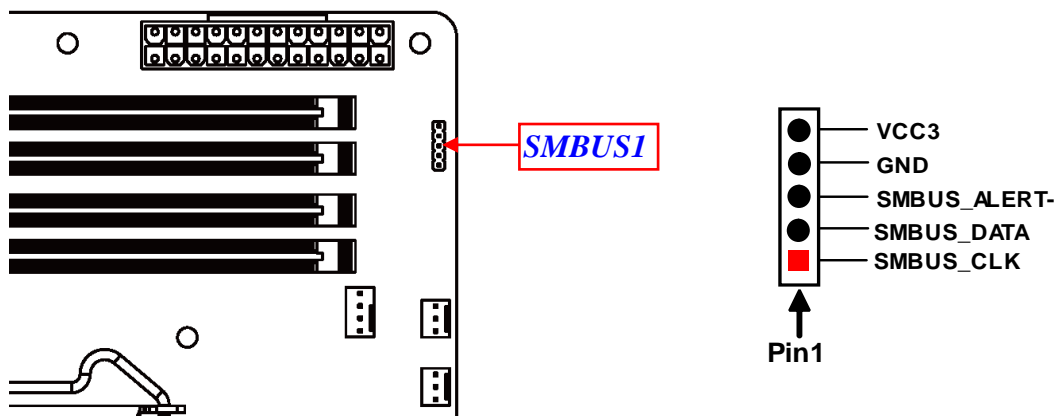

2-2-4 Maximum Voltage & Current Limit

Below is a list of maximum voltage & Current Limit specification for motherboard interface (including but not limited to slots, connectors, wafers and headers) for setup reference:

Location	Function	Working Voltage	Current Support
JP2	COM1 Port Pin9 Function	5V/12V	500mA
JP3	COM2 Port Pin9 Function	5V/12V	500mA
UL1/UL2	1.0GbE RJ-45 LAN Port	5V	1.5A
CPUFAN1	CPU FAN	12V	1.5A
SYSFAN1/2/3/4/5/6	System Fan Connectors	12V	1.5A
FP	Front Panel Header	5V	1A
FP_USB2/FP_USB3	USB 2.0 Port	5V	1.5A
FP_USB1	USB 3.2(Gen.1)	5V	1.5A
GPIO	GPIO Port Header	5V	1A
PS2KBMS	PS/2 Keyboard & Mouse	5V	500mA

Chapter 3

Introducing BIOS

Notice! The BIOS options in this manual are for reference only. Different configurations may lead to difference in BIOS screen and BIOS screens in manuals are usually the first BIOS version when the board is released and may be different from your purchased motherboard. Users are welcome to download the latest BIOS version form our official website.

The BIOS is a program located on a Flash Memory on the motherboard. This program is a bridge between motherboard and operating system. When you start the computer, the BIOS program will gain control. The BIOS first operates an auto-diagnostic test called POST (power on self test) for all the necessary hardware, it detects the entire hardware device and configures the parameters of the hardware synchronization. Only when these tasks are completed done it gives up control of the computer to operating system (OS). Since the BIOS is the only channel for hardware and software to communicate, it is the key factor for system stability, and in ensuring that your system performance as its best.

3-1 Entering Setup

Power on the computer and by pressing immediately allows you to enter Setup. If the message disappears before your respond and you still wish to enter Setup, restart the system to try again by turning it OFF then ON or pressing the “RESET” button on the system case. You may also restart by simultaneously pressing <Ctrl>, <Alt> and <Delete> keys. If you do not press the keys at the correct time and the system does not boot, an error message will be displayed and you will again be asked to

Press to enter Setup; press < F7> to enter pop-up Boot menu.

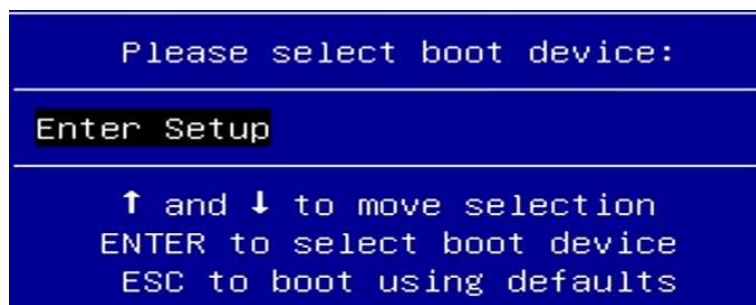

BIOS Boot Menu Screen (boot device options please refer to actual configuration)

3-2 BIOS Menu Screen

The following diagram show a general BIOS menu screen:

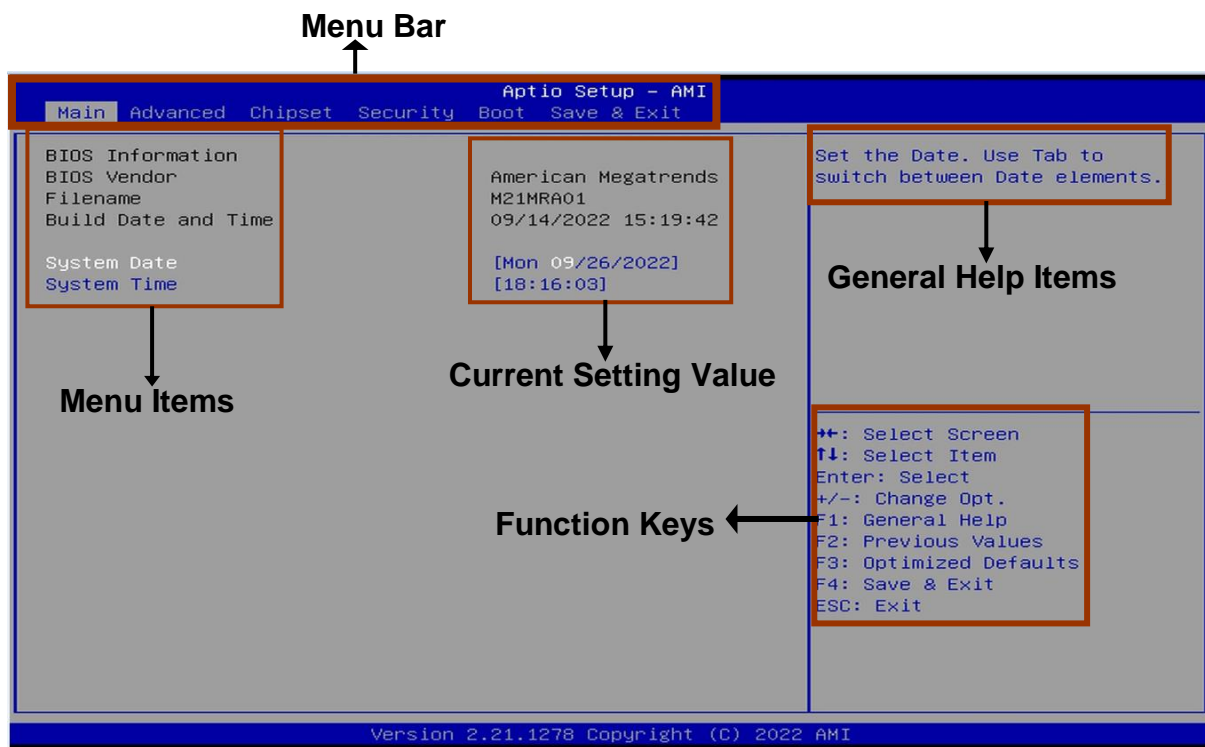

3-3 Function Keys

In the above BIOS Setup main menu of, you can see several options. We will explain these options step by step in the following pages of this chapter, but let us first see a short description of the function keys you may use here:

- Press ←→ (left, right) to select screen.
- Press ↑↓ (up, down) to choose, in the main menu, the option you want to confirm or to modify.
- Press <Enter> to select.
- Press <+>/<-> keys when you want to modify the BIOS parameters for the active option.
- [F1]: General help.
- [F2]: Previous values.
- [F3]: Optimized defaults.
- [F4]: Save & Exit.
- Press <Esc> to exit from BIOS Setup.

3-4 Getting Help

Main Menu

The on-line description of the highlighted setup function is displayed at the top right corner the screen.

Status Page Setup Menu/Option Page Setup Menu

Press **【F1】** to pop up a small help window that describes the appropriate keys to use and the possible selections for the highlighted item. To exit the Help Window, press **<Esc>**.

3-5 Menu Bars

There are six menu bars on top of BIOS screen:

Main	To change system basic configuration
Advanced	To change system advanced configuration
Chipset	To change chipset configuration
Security	Password settings
Boot	To change boot settings
Save & Exit	Save setting, loading and exit options.

User can press the right or left arrow key on the keyboard to switch from menu bar. The selected one is highlighted.

3-6 Main Menu

Main menu screen includes some basic system information. Highlight the item and then use the **<+>** or **<->** and numerical keyboard keys to select the value you want in each item.

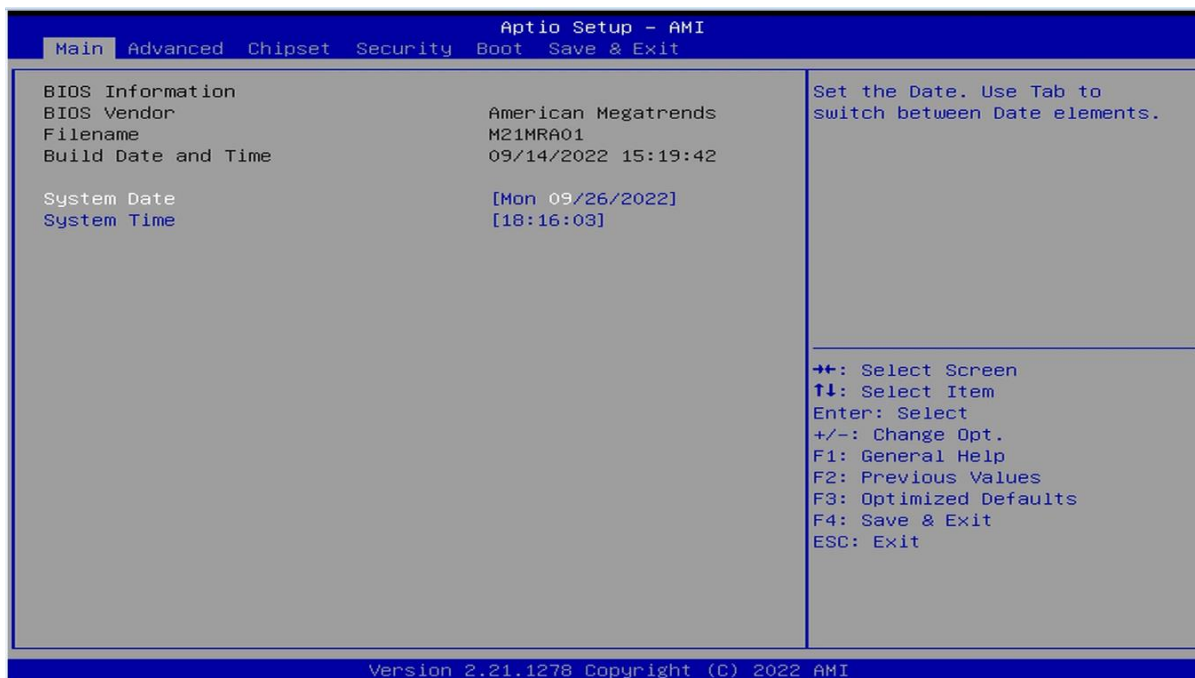

System Date

Set the date. Please use [Tab] to switch between date elements.

System Time

Set the time. Please use [Tab] to switch between time elements.

3-7 Advanced Menu

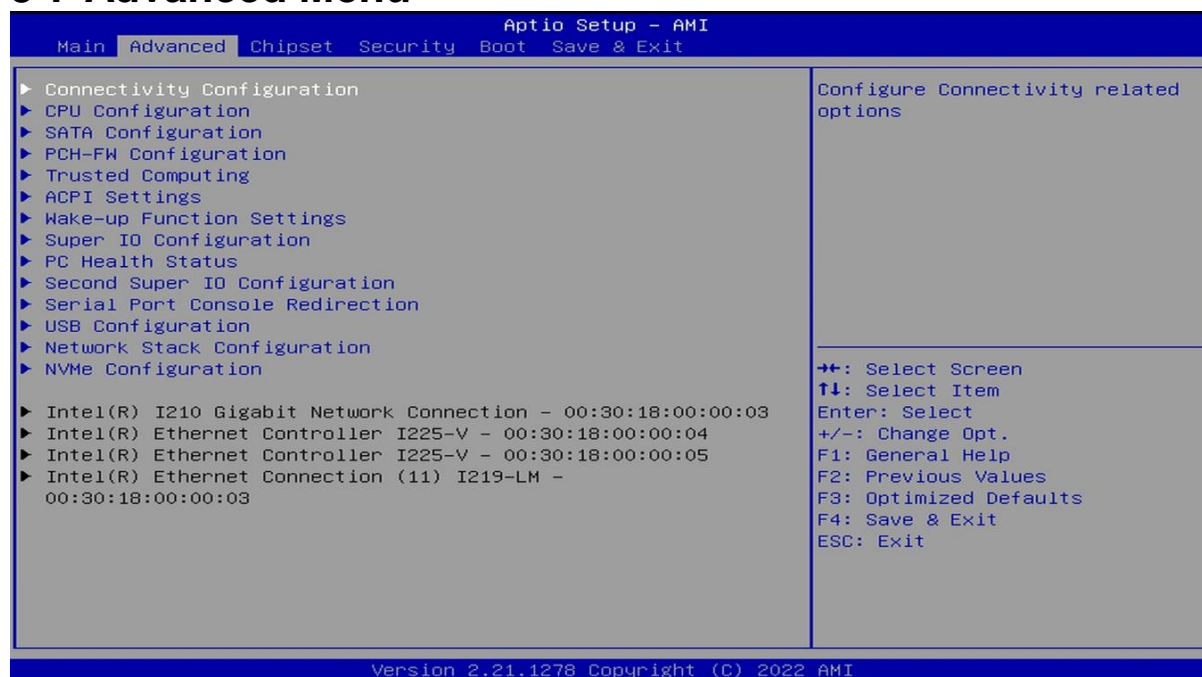

▶ **Connectivity Configuration**

Use this item to configure Connectivity related options. Press [Enter] to make settings for the following sub-items:

CNVi present

CNVi Configuration

CNVi Mode

This option configures Connectivity.

The optional settings: [Disabled Integrated]; [Auto Detection].

[Auto Detection] means that if Discrete solution is discovered it will be enabled by default. Otherwise Integrated solution (CNVi) will be enabled;

[Disabled Integrated] disables Integrated Solution.

NOTE: When CNVi is present, the GPIO pins that are used for radio interface cannot be assigned to the other native function.

▶ **CPU Configuration**

Press [Enter] to view current CPU configuration and make settings for the following sub-items:

Hyper-Threading

Use this item to enable or disable Hyper-Threading Technology.

The optional settings: [Disabled]; [Enabled].

Intel (VMX) Virtualization Technology

The optional settings: [Disabled]; [Enabled].

When set as [Enabled], a VMM can utilize the additional hardware capabilities provided by Vanderpool Technology.

Intel(R) SpeedStep(tm)

This item allows more than two frequency ranges to be supported.

The optional settings: [Disabled]; [Enabled].

C states

Use this item to enable or disable CPU Power Management. When set as

[Enabled], it allows CPU to go to C states when it's not 100% utilized.
The optional settings: [Disabled]; [Enabled].

Turbo Mode

Use this item to enable or disable processor Turbo Mode (requires Intel Speed Step or Intel Speed Shift to be available and enabled.)

The optional settings: [Disabled]; [Enabled].

**Note: 'Turbo Mode' item may or may not show up, depending on different CPU.*

▶ **SATA Configuration**

Press [Enter] to make settings for the following sub-items:

SATA Configuration

SATA Controller(s)

Use this item to enable or disable SATA Device.

The optional settings: [Enabled]; [Disabled].

When set as [Enabled], the following items shall appear:

SATA Mode Selection

This item determines how SATA controller(s) operate.

The optional settings: [AHCI]; [RAID].

SATA1/SATA2/SATA3/SATA4/SATA5/SATA6/SATA7/SATA8

Port

Use this item to enable or disable SATA Port.

The optional settings: [Disabled]; [Enabled].

Hot Plug

Use this item to designate this port as Hot Pluggable.

The optional settings: [Disabled]; [Enabled].

**Note: Q4700 chipset supports SATA1 to SATA6, W4800 supports SATA1 to SATA8.*

▶ **PCH-FW Configuration**

Press [Enter] to view Management Engine Technology Parameters and make settings in the following sub-item:

ME Firmware Version

ME Firmware Mode

TPM Device Selection

Use this item to select TPM device: PTT or dTPM PTT- Enables PTT in SkuMgr
Dtpm – Disables PTT in SkuMgr

***Warning!** PTT/dTPM will be disabled and all data saved on it will be lost*

The optional settings: [dTPM]; [PTT]

▶ **Firmware Update Configuration**

Press [Enter] to make settings for 'Me FW Image Re-Flash'.

Me FW Image Re-Flash

Use this item to enable or disable Me FW Image Re-Flash function.

The optional settings: [Disabled]; [Enabled].

** Note: In the case that user needs to update Me firmware, user should set 'Me FW Image Re-Flash' as [Enabled], save the settings and exit. The system will turn off and reboot after 4 seconds. If the user goes to BIOS screen again will find this item is set again as [Disabled], but user can still re-flash to update firmware next time.*

▶ **Trusted Computing**

Press [Enter] to make settings for the following sub-items:

TPM2.0 Device Found

NOTE: TPM function is optional, MM21-Q4702 & MM21-W4802 model support TPM2.0

Security Device Support

Use this item to Enables or Disables BIOS support for security device. O.S. will not show security Device. TCG EFI protocol and INT1A interface will not be available.

The optional settings: [Disabled]; [Enabled].

When set as [Enabled], the following items shall appear:

Pending operation

Use this item to schedule an operation for the security device.

The optional settings: [None]; [TPM Clear].

NOTE: Your computer will reboot during restart in order to change state of security device.

▶ **ACPI Settings**

Press [Enter] to make settings for the following sub-items:

ACPI Settings

ACPI Sleep State

Use this item to select the highest ACPI sleep state the system will enter when the SUSPEND button is pressed.

The optional settings: [Suspend Disabled]; [S3 (Suspend to RAM)].

▶ **Wake-up Function Settings**

Press [Enter] to make settings for the following sub-items:

Wake-up System With Fixed Time

Use this item to enable or disable System wake on alarm event.

The optional settings: [Disabled]; [Enabled].

When set as [Enabled], the following items shall appear:

Wake-up Hour

Use this item to select 0-23. For example enter 3 for 3am and 15 for 3pm.

Wake-up Minute

Use this item to select 0-59.

Wake-up Second

Use this item to select 0-59.

Wake-up System with Dynamic Time

Use this item to enable or disable System wake on alarm event.

System will wake on the current time + Increase minute(s).

The optional settings: [Disabled]; [Enabled].

When set as [Enabled], system will wake on the current time + increased minute(s).

PS2 KB/MS Wake-up

Use this item to enable or disable PS2 KB/MS Wake-up from (S3/S4/S5).

The optional settings: [Disabled]; [Enabled].

***Note:** This function is supported when 'ERP Support' is set as [Disabled].

USB S3/S4 Wake-up

Use this item to enable or disable USB Power after System Shutdown.

The optional settings: [Disabled]; [Enabled].

***Note:** This function is supported when 'ERP Support' is set as [Disabled].

USB S5 Power

Use this item to USB Power after system shutdown support only disable ERP Function.

The optional settings: [Disabled]; [Enabled].

▶ **Super IO Configuration**

Press [Enter] to make settings for the following sub-items:

Super IO Configuration

ERP Support

Use this item to select Energy-Related Products function. This item should be set as [Disabled] if you wish to have all active wake-up functions.

The optional settings: [Disabled]; [Auto].

▶ **Serial Port 1 Configuration**

Press [Enter] to make settings for the following items:

Serial Port 1 Configuration

Serial Port

Use this item to enable or disable Serial Port (COM).

The optional settings: [Disabled]; [Enabled].

When set as [Enabled], user can make further settings in the following items:

Device Settings

Change Settings

Use this item to select an optimal setting for Super IO Device.

The optional settings: [IO=3F8h; IRQ=4;]; [IO=3F8h; IRQ=3,4,5,7,10,11;]; [IO=2F8h; IRQ=3,4,5,7,10,11;]; [IO=3E8h; IRQ=3,4,5,7,10,11;]; [IO=2E8h; IRQ=3,4,5,7,10,11;].

Transmission Mode Select

The optional settings: [RS422]; [RS232]; [RS485].

***Note:** Q4700 chipset supports RS232/RS422/RS485, W4800 supports RS232 only.

Mode Speed Select

Use this item to select RS232/RS422/RS485 Speed.

The optional settings: [RS232/RS422/RS485=250Kbps]; [RS232=1Mbps, RS422/RS485=10Mbps].

▶ **Serial Port 2 Configuration**

Press [Enter] to make settings for the following items:

Serial Port 2 Configuration

Serial Port

Use this item to enable or disable Serial Port (COM).

The optional settings: [Disabled]; [Enabled].

When set as [Enabled], user can make further settings in the following items:

Device Settings

Change Settings

Use this item to select an optimal setting for Super IO Device.

The optional settings: [IO=2F8h; IRQ=3;]; [IO=3F8h; IRQ=3,4,5,7,10,11;]; [IO=2F8h; IRQ=3,4,5,7,10,11;]; [IO=3E8h; IRQ=3,4,5,7,10,11;]; [IO=2E8h; IRQ=3,4,5,7,10,11;].

Transmission Mode Select

The optional settings: [RS422]; [RS232]; [RS485].

**Note: Q4700 chipset supports RS232/RS422/RS485, W4800 supports RS232 only.*

Mode Speed Select

Use this item to select RS232/RS422/RS485 Speed.

The optional settings: [RS232/RS422/RS485=250Kbps]; [RS232=1Mbps, RS422/RS485=10Mbps].

► **Serial Port 3 Configuration**

Press [Enter] to make settings for the following items:

Serial Port 3 Configuration

Serial Port

Use this item to enable or disable Serial Port (COM).

The optional settings: [Disabled]; [Enabled].

When set as [Enabled], user can make further settings in the following items:

Device Settings

Change Settings

Use this item to select an optimal setting for Super IO Device.

The optional settings: [IO=3E8h; IRQ=10;]; [IO=3F8h; IRQ=3,4,5,7,10,11;]; [IO=2F8h; IRQ=3,4,5,7,10,11;]; [IO=3E8h; IRQ=3,4,5,7,10,11;]; [IO=2E8h; IRQ=3,4,5,7,10,11;]; [IO=3E0h; IRQ=3,4,5,7,10,11;]; [IO=2E0h; IRQ=3,4,5,7,10,11;].

**Note: 'Serial Port 3' item may or may not show up, depending on different chipset. Q4700 chipset supports this item.*

► **Serial Port 4 Configuration**

Press [Enter] to make settings for the following items:

Serial Port 4 Configuration

Serial Port

Use this item to enable or disable Serial Port (COM).

The optional settings: [Disabled]; [Enabled].

When set as [Enabled], user can make further settings in the following items:

Device Settings

Change Settings

Use this item to select an optimal setting for Super IO Device.

The optional settings: [IO=2E8h; IRQ=10;]; [IO=3F8h; IRQ=3,4,5,7,10,11;]; [IO=2F8h; IRQ=3,4,5,7,10,11;]; [IO=3E8h; IRQ=3,4,5,7,10,11;]; [IO=2E8h; IRQ=3,4,5,7,10,11;]; [IO=3E0h; IRQ=3,4,5,7,10,11;]; [IO=2E0h; IRQ=3,4,5,7,10,11;].

****Note:** ‘Serial Port 4’ item may or may not show up, depending on different chipset. Q4700 chipset supports this item.*

► **Serial Port 5 Configuration**

Press [Enter] to make settings for the following items:

Serial Port 5 Configuration

Serial Port

Use this item to enable or disable Serial Port (COM).

The optional settings: [Disabled]; [Enabled].

When set as [Enabled], user can make further settings in the following items:

Device Settings

Change Settings

Use this item to select an optimal setting for Super IO Device.

The optional settings: [IO=3E0h; IRQ=11;]; [IO=3F8h; IRQ=3,4,5,7,10,11;]; [IO=2F8h; IRQ=3,4,5,7,10,11;]; [IO=3E8h; IRQ=3,4,5,7,10,11;]; [IO=2E8h; IRQ=3,4,5,7,10,11;]; [IO=3E0h; IRQ=3,4,5,7,10,11;]; [IO=2E0h; IRQ=3,4,5,7,10,11;].

****Note:** ‘Serial Port 5’ item may or may not show up, depending on different chipset. Q4700 chipset supports this item.*

► **Serial Port 6 Configuration**

Press [Enter] to make settings for the following items:

Serial Port 6 Configuration

Serial Port

Use this item to enable or disable Serial Port (COM).

The optional settings: [Disabled]; [Enabled].

When set as [Enabled], user can make further settings in the following items:

Device Settings

Change Settings

Use this item to select an optimal setting for Super IO Device.

The optional settings: [IO=2E0h; IRQ=11;]; [IO=3F8h; IRQ=3,4,5,7,10,11;]; [IO=2F8h; IRQ=3,4,5,7,10,11;]; [IO=3E8h; IRQ=3,4,5,7,10,11;]; [IO=2E8h; IRQ=3,4,5,7,10,11;]; [IO=3E0h; IRQ=3,4,5,7,10,11;]; [IO=2E0h; IRQ=3,4,5,7,10,11;].

****Note:** ‘Serial Port 6’ item may or may not show up, depending on different chipset. Q4700 chipset supports this item.*

WatchDog Reset Timer

Use this item to enable or disable WDT reset function. When set as [Enabled], the

following sub-items shall appear:

WatchDog Reset Timer Value

User can select a value in the range of [4] to [255] seconds when 'WatchDog Reset Timer Unit' set as [Sec]; or in the range of [4] to [255] minutes when 'WatchDog Reset Timer Unit' set as [Min].

WatchDog Reset Timer Unit

The optional settings: [Sec.]; [Min.].

ATX Power Emulate AT Power

This item support Emulate AT power function, MB power On/Off control by power supply. Use needs to select 'AT or ATX Mode' on MB jumper at first (refer to JAT_ATX jumper setting Pin 1&2 of for ATX Mode & Pin 2&3 of AT Mode Select).

Case Open Detect

Use this item to detect case has already open or not, show message in POST.

The optional settings: [Disabled]; [Enabled].

When set as [Enabled], system will detect if COPEN has been short or not (*refer to **COPEN** jumper setting for Case Open Detection*); if Pin 1&2 of **COPEN** are short, system will show Case Open Message during POST.

▶ **PC Health Status**

Press [Enter] to view current hardware health status, make further settings in 'SmartFAN Configuration' and set value in 'Shutdown Temperature'.

▶ **SmartFAN Configuration**

Press [Enter] to make settings for 'SmartFan Configuration':

SmartFAN Configuration

CPUFAN1 / SYSFAN1 / SYSFAN2 Smart Mode

The optional settings: [Disabled]; [Enabled].

When set as [Enabled], the following sub-items shall appear:

CPUFAN1 / SYSFAN1 / SYSFAN2 Full-Speed Temperature

Use this item to set CPUFAN/SYSFAN full speed temperature. Fan will run at full speed when above this pre-set temperature.

CPUFAN1 / SYSFAN1 / SYSFAN2 Full-Speed Duty

Use this item to set CPUFAN/SYSFAN full-speed duty. Fan will run at full speed when above this pre-set duty.

CPUFAN1 / SYSFAN1 / SYSFAN2 Idle-Speed Temperature

Use this item to set CPUFAN /SYSFAN idle speed temperature. Fan will run at idle speed when below this pre-set temperature.

CPUFAN1 / SYSFAN1 / SYSFAN2 Idle-Speed Duty

Use this item to set CPUFAN/SYSFAN idle speed duty. Fan will run at idle speed when below this pre-set duty.

▶ **Second Super IO Configuration**

Press [Enter] to view current hardware health status, make further settings in 'SmartFAN Configuration' and set value in 'Shutdown Temperature'.

▶ **SmartFAN Configuration**

Press [Enter] to make settings for 'SmartFAN Configuration':

SmartFAN Configuration

SYSFAN3/4/5/6 Smart Mode

The optional settings: [Disabled]; [Enabled].

When set as [Enabled], the following sub-items shall appear:

SYSFAN3/4/5/6 Full-Speed Temperature

Use this item to set SYSFAN full speed temperature. Fan will run at full speed when above this pre-set temperature.

SYSFAN3/4/5/6 Full-Speed Duty

Use this item to set SYSFAN full-speed duty. Fan will run at full speed when above this pre-set duty.

SYSFAN3/4/5/6 Idle-Speed Temperature

Use this item to set SYSFAN idle speed temperature. Fan will run at idle speed when below this pre-set temperature.

SYSFAN3/4/5/6 Idle-Speed Duty

Use this item to set /SYSFAN idle speed duty. Fan will run at idle speed when below this pre-set duty.

▶ **Serial Port Console Redirection**

COM1

Console Redirection

Use this item to enable or disable COM1 Console Redirection.

The optional settings: [Disabled]; [Enabled].

When set as [Enabled], user can make further settings in the following items:

▶ **Console Redirection Settings**

The settings specify how the host computer and the remote computer (which the user is using) will exchange data. Both computers should have the same or compatible settings.

Press [Enter] to make settings for the following sub-items.

COM1

Console Redirection Settings

Terminal Type

The optional settings: [VT100]; [VT100+]; [VT-UTF8]; [ANSI].

Emulation: **[ANSI]**: Extended ASCII char set; **[VT100]**: ASCII char set;

[VT100+]: Extends VT100 to support color, function keys, etc.; **[VT-UTF8]**:

Uses UTF8 encoding to map Unicode chars onto 1 or more bytes.

Bits per second

Use this item to select serial port transmission speed. The speed must be matched on the other side. Long or noisy lines may require lower speeds.

The optional settings: [9600]; [19200]; [38400]; [57600]; [115200].

Data Bits

The optional settings: [7]; [8].

Parity

A parity bit can be sent with the data bits to detect some transmission errors.

The optional settings: [None]; [Even]; [Odd]; [Mark]; [Space].

[Even]: parity bit is 0 if the num of 1's in the data bits is even;

[Odd]: parity bit is 0 if num of 1's in the data bits is odd;

[Mark]: parity bit is always 1;

[Space]: parity bit is always 0;

[Mark] and [Space]: parity do not allow for error detection.

Stop Bits

Stop bits indicate the end of a serial data packet. (A start bit indicates the beginning). The standard setting is 1 stop bit. Communication with slow devices may require more than 1 stop bit.

The optional settings: [1]; [2].

Flow Control

Flow control can prevent data loss from buffer overflow. When sending data, if the receiving buffers are full, a “stop” signal can be sent to stop the data flow. Once the buffers are empty, a “start” signal can be sent to re-start the flow. Hardware flow control uses two wires to send start/stop signals.

The optional settings: [None]; [Hardware RTS/CTS].

VT-UTF8 Combo Key Support

Use this item to enable VT-UTF8 Combination Key Support for ANSI/VT100 terminals.

The optional settings: [Disabled]; [Enabled].

Recorder Mode

With this mode enable only text will be sent. This is to capture Terminal data.

The optional settings: [Disabled]; [Enabled].

Resolution 100x31

Use this item to enable or disable extended terminal resolution.

The optional settings: [Disabled]; [Enabled].

Putty KeyPad

Use this item to select FunctionKey and KeyPad on Putty.

The optional settings: [VT100]; [LINUX]; [XTERMR6]; [SCO]; [ESCN]; [VT400].

Serial Port for Out-of-Band Management/

Windows Emergency Management Services (EMS)

Console Redirection EMS

Use this item to enable or disable Console Redirection.

The optional settings: [Disabled]; [Enabled].

When set as [Enabled], the following sub-items shall appear:

► Console Redirection Settings

The settings specify how the host computer and the remote computer (which the user is using) will exchange data. Both computers should have the same or compatible settings.

Press [Enter] to make settings for the following items:

Out-of-Band Mgmt Port

Terminal Type EMS

The optional settings: [VT100]; [VT100+]; [VT-UTF8]; [ANSI].

[VT-UTF8] is the preferred terminal type for out-of-band management. The next best choice is [VT100+] and them [VT100]. See above, in Console Redirection Settings page, for more help with Terminal Type/Emulation.

Bits per second EMS

Use this item to select serial port transmission speed. The speed must be matched on the other side. Long or noisy lines may require lower speeds.

The optional settings: [9600]; [19200]; [57600]; [115200].

Flow Control EMS

Flow control can prevent data loss from buffer overflow. When sending data, if the receiving buffers are full, a “stop” signal can be sent to stop the data flow. Once the buffers are empty, a “start” signal can be sent to re-start the flow. Hardware flow control uses two wires to send start/stop signals.

The optional settings: [None]; [Hardware RTS/CTS]; [Software Xon/Xoff].

Data Bits EMS

The default setting is: [8].

**This item may or may not show up, depending on different configuration.*

Parity EMS

The default setting is: [None].

**This item may or may not show up, depending on different configuration.*

Stop Bits EMS

The default setting is: [1].

**This item may or may not show up, depending on different configuration.*

▶ **USB Configuration**

Press [Enter] to make settings for the following sub-items:

USB Configuration

XHCI Hand-off

This is a workaround for Oses without XHCI hand-off support. The XHCI ownership change should be claimed by XHCI driver.

The optional settings: [Enabled]; [Disabled].

USB Mass Storage Driver Support

Use this item to enable or disable USB mass storage driver support.

The optional settings: [Disabled]; [Enabled].

USB hardware delays and time-outs:

USB transfer time-out

Use this item to set the time-out value for Control, Bulk, and Interrupt transfers.

The optional settings: [1 sec]; [5 sec]; [10 sec]; [20 sec].

Device reset time-out

Use this item to set USB mass storage device Start Unit command time-out.

The optional settings: [10 sec]; [20 sec]; [30 sec]; [40 sec].

Device power-up delay

Use this item to set maximum time the device will take before it properly reports itself to the host controller. ‘Auto’ uses default value: for a root port it is 100 ms, for a hub port the delay is taken from hub descriptor.

The optional settings: [Auto]; [Manual].

Select [**Manual**] you can set value for the following sub-item: ‘**Device power-up delay in seconds**’, the delay range in from 1 to 40 seconds, in one second increments.

▶ **Network Stack Configuration**

Press [Enter] to go to ‘**Network Stack**’ screen to make further settings.

Network Stack

Use this item to enable or disable UEFI Network Stack.

The optional settings: [Disabled]; [Enabled].

When set as [Enabled], the following sub-items shall appear:

IPv4 PXE Support

Use this item to enable IPv4 PXE boot support. When set as [Disabled], IPv4 boot support will not be available.

The optional settings: [Disabled]; [Enabled].

IPv6 PXE Support

Use this item to enable IPv6 PXE boot support. When set as [Disabled], IPv6 boot support will not be available.

The optional settings: [Disabled]; [Enabled].

PXE boot wait time

Use this item to set wait time to press [ESC] key to abort the PXE boot.

Use either [+] / [-] or numeric keys to set the value.

Media detect count

Use this item to set number of times presence of media will be checked.

Use either [+] / [-] or numeric keys to set the value.

▶ **NVMe Configuration**

Press [Enter] to view current NVMe Configuration.

**Note: options only when NVME device is available.*

**Note: When 'CSM Support' set as [Disabled] and 'SATA Mode Selection' set as [RAID], the following sub-items shall appear:*

- ▶ **Intel(R) I210 Gigabit Network Connection - XX:XX:XX:XX:XX:XX**
This item shows current network brief information.
- ▶ **Intel(R) Ethernet Controller I225-V - XX:XX:XX:XX:XX:XX**
This item shows current network brief information.
- ▶ **Intel(R) Ethernet Controller I225-V - XX:XX:XX:XX:XX:XX**
This item shows current network brief information.
- ▶ **Intel(R) Ethernet Connection (11) I219-LM - XX:XX:XX:XX:XX:XX**
This item shows current network brief information.

3-8 Chipset Menu

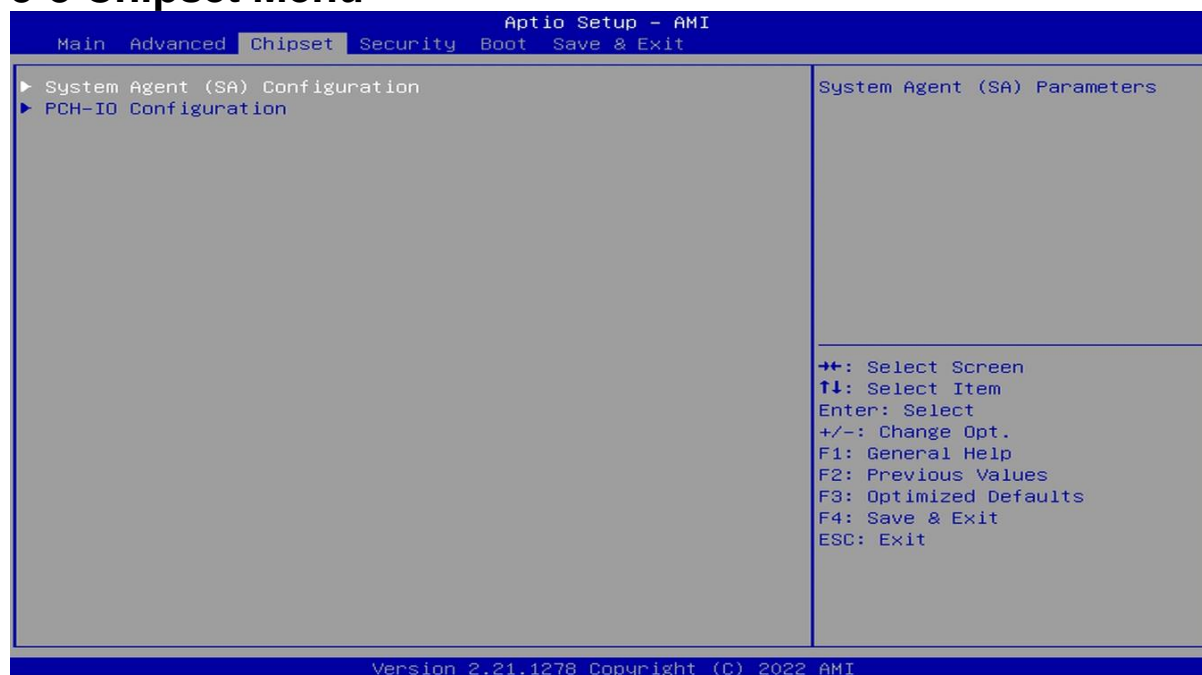

▶ **System Agent (SA) Configuration**

Press [Enter] to make settings for the following sub-items:

System Agent (SA) Configuration

VT-d

▶ **Memory Configuration**

Press [Enter] to view brief information for the working memory module.

▶ **Graphics Configuration**

Press [Enter] to make further settings for Graphics Configuration.

Graphics Configuration

Primary Display

Use this item to select which of IGFX/PEG Graphics device should be Primary Display Or select SG for Switchable Gfx.

The optional settings: [Auto]; [IGFX]; [PEG].

***Note:** *'Primary Display' item may or may not show up, depending on different CPU.*

Internal Graphics

Use this item to keep IGFX enabled based on the setup options.

The optional settings: [Auto]; [Disabled]; [Enabled].

Aperture Size

Use this item to select the Aperture Size.

***Note:** *Above 4GB MMIO BIOS assignment is automatically enabled when selecting 2048MB aperture. To use this feature, please disable CSM Support.*

The optional settings: [128MB]; [256MB]; [512MB]; [1024MB]; [2048MB].

DVMT Pre-Allocated

Use this item to select DVMT 5.0 Pre-Allocated (Fixed) Graphics Memory size used by the Internal Graphics Device.

The optional settings: [32M]; [64M].

DVMT Total Gfx Mem

Use this item to select DVMT5.0 Total Graphic Memory size used by the Internal Graphics Device.

The optional settings: [128M]; [256M]; [MAX].

► **PEG Port Configuration**

Press [Enter] to make further settings for PEG port options.

PEG Port Configuration

PCIE2 Slot

Enable Root Port

Use this item to enable or disable the Root Port. Root Port will Always Enable if set x8 Bifurcation.

The optional settings: [Disabled]; [Enabled].

Max Link Speed

Use this item to configure PEG 0:1:0 Max Speed.

The optional settings: [Auto]; [Gen1]; [Gen2]; [Gen3].

PCIE4 Slot (Bifurcation)

Enable Root Port

Use this item to enable or disable the Root Port

The optional settings: [Disabled]; [Enabled].

Max Link Speed

Use this item to configure PEG 0:1:1 Max Speed.

The optional settings: [Auto]; [Gen1]; [Gen2]; [Gen3].

Detect Non-Compliance Device

This item is for user to detect Non-Compliance PCI Express Device in PEG.

The optional settings: [Disabled]; [Enabled].

► **PCH-IO Configuration**

Press [Enter] to make settings for the following sub-items:

PCH-IO Configuration

HD Audio

Use this item to control Detection of the HD-Audio device.

The optional settings: [Disabled]; [Enabled].

[Disabled]: HDA will be unconditionally disabled.

[Enabled]: HAD will be unconditionally enabled.

Onboard Lan1 Controller

Use this item to enable or disable corresponding onboard NIC device or controller.

The optional settings: [Enabled]; [Disabled].

When set as [Enabled], the following sub-items shall appear:

Wake on LAN Enable

Use this item to enable or disable integrated LAN to wake the system.

The optional settings: [Enabled]; [Disabled].

Onboard Lan2 / Lan3 / Lan4 Controller

Use this item to control the PCI Express Root Port.

The optional settings: [Disabled]; [Enabled].

System State After Power Failure

Use this item to specify what state to go to when power is re-applied after a power failure (G3 state).

The optional settings: [Always On]; [Always Off]; [Former State].

***Note:** The option [Always On] and [Former State] are affected by 'ERP Support' function. Please disable ERP to support [Always On] and [Former State] function.

3-9 Security Menu

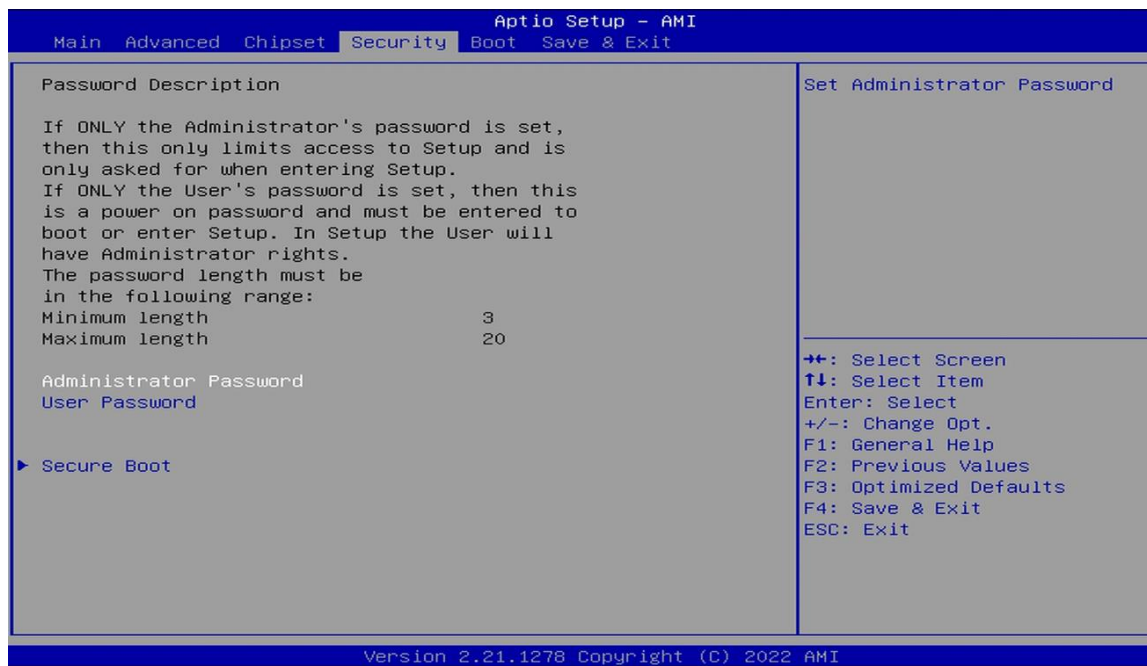

Security menu allow users to change administrator password and user password settings.

Administrator Password

If there is no password present on system, please press [Enter] to create new administrator password. If password is present on system, please press [Enter] to verify old password then to clear/change password. Press again to confirm the new administrator password.

User Password

If there is no password present on system, please press [Enter] to create new administrator password. If password is present on system, please press [Enter] to verify old password then to clear/change password. Press again to confirm the new administrator password.

► Secure Boot

Press [Enter] to make customized secure settings:

System Mode

Secure Boot

Secure Boot feature is Active if Secure Boot is Enabled, Platform Key(PK) is enrolled and the System is in User mode. The mode change requires platform reset.

The optional settings: [Disabled]; [Enabled].

Secure Boot Mode

Set UEFI Secure Boot Mode to Standard mode or Custom mode. This change is

effective after save. After reset, this mode will return to Standard mode.
In Custom mode, Secure Boot Policy variables can be configured by a physically present user without full authentication.
The optional settings: [Standard]; [Custom].
When set as [**Custom**], user can make further settings in the following items that show up:

▶ **Restore Factory Keys**

Use this item to force system to User Mode, to install factory default Secure Boot key databases.

▶ **Reset To Setup Mode**

▶ **Key Management**

This item enables expert users to modify Secure Boot Policy variables without full authentication, which includes the following items:

Vendor Keys

Factory Key Provision

This item is for user to install factory default Secure Boot keys after the platform reset and while the System is in Setup mode.

The optional settings: [Disabled]; [Enabled].

▶ **Restore Factory Keys**

Use this item to force system into User Mode. Install factory default Secure Boot key databases.

▶ **Reset To Setup Mode**

▶ **Export Secure Boot variables**

▶ **Enroll Efi Image**

This item allows the image to run in Secure Boot mode.

Enroll SHA256 Hash certificate of a PE image into Authorized Signature Database (db).

Device Guard Ready

▶ **Remove 'UEFI CA' from DB**

▶ **Restore DB defaults**

Use this item to restore DB variable to factory defaults.

Secure Boot variable/Size/Keys/Key Source

▶ **Platform Key(PK)/Key Exchange Keys/Authorized Signatures/Forbidden Signatures/ Authorized TimeStamps/OsRecovery Signatures**

Use this item to enroll Factory Defaults or load certificates from a file:

1. Public Key Certificate:

- a) EFI_SIGNATURE_LIST
- b) EFI_CERT_X509 (DER)
- c) EFI_CERT_RSA2048 (bin)
- d) EFI_CERT_SHAXXX

2. Authenticated UEFI Variable

3. EFI PE/COFF Image (SHA256)

Key Source: Factory, External, Mixed.

3-10 Boot Menu

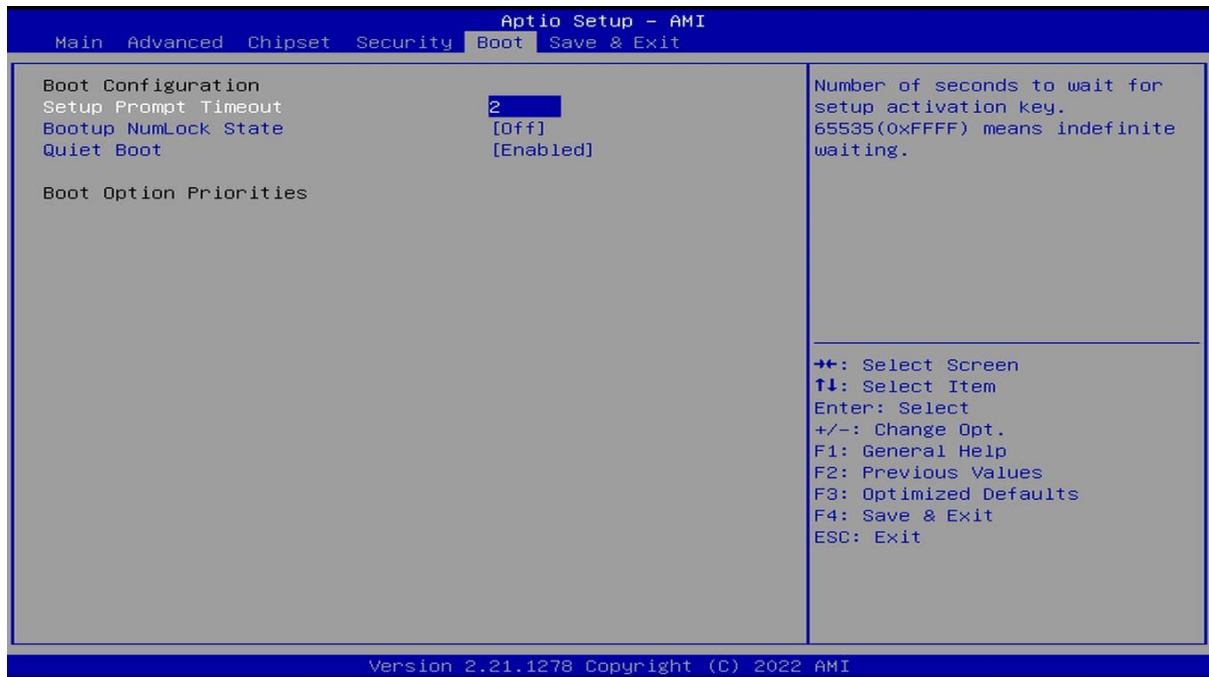

Boot Configuration

Setup Prompt Timeout

Use this item to set number of seconds to wait for setup activation key. 65535 (0xFFFF) means indefinite waiting.

Bootup NumLock State

Use this item to select keyboard NumLock state.

The optional setting are: [On]; [Off].

Quiet Boot

The optional settings: [Disabled]; [Enabled].

Boot Option Priorities

3-11 Save & Exit Menu

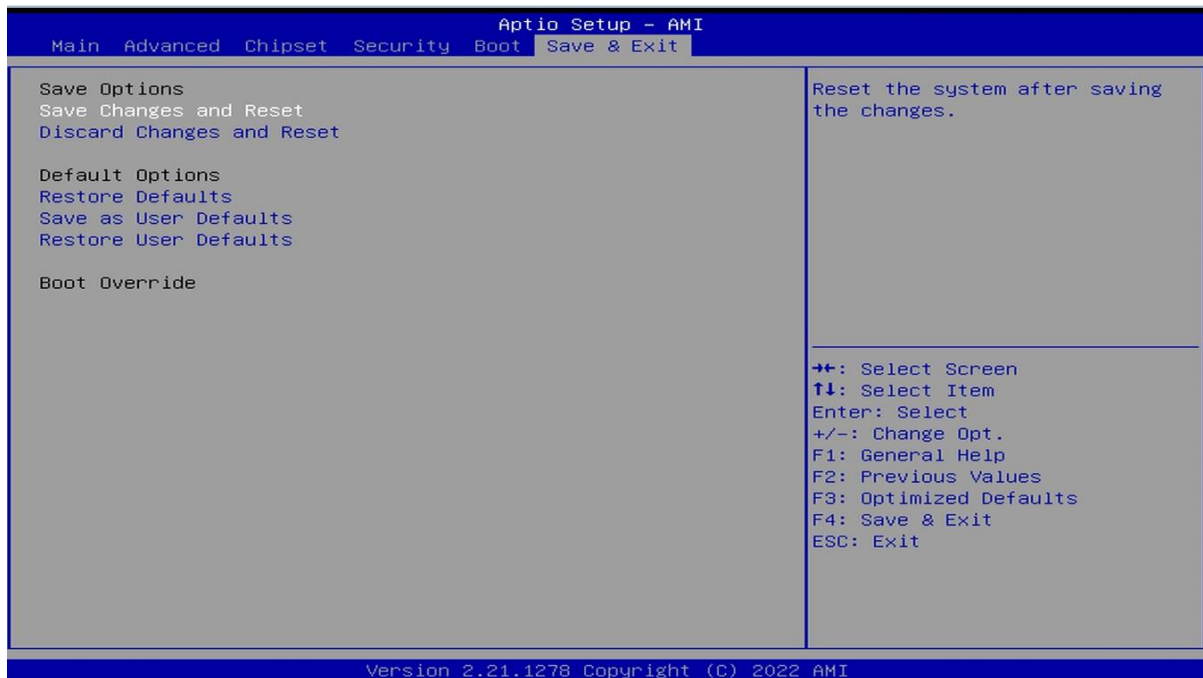

Save Options

Save Changes and Reset

This item allows user to reset the system after saving the changes.

Discard Changes and Reset

This item allows user to reset the system without saving any changes.

Default Options

Restore Defaults

Use this item to restore /load default values for all the setup options.

Save as User Defaults

Use this item to save the changes done so far as user defaults.

Restore User Defaults

Use this item to restore the user defaults to all the setup options.

Boot Override