

NAF591 Series

User's Manual

No. G03-NAF591-F

Rev: 5.0

Release date: March 17, 2020

Trademark:

* Specifications and Information contained in this documentation are furnished for information use only, and are subject to change at any time without notice, and should not be construed as a commitment by manufacturer.

TABLE OF CONTENT

ENVIRONMENTAL SAFETY INSTRUCTION.....	iii
ENVIRONMENTAL PROTECTION ANNOUCEMENT.....	iii
USER'S NOTICE.....	iv
MANUAL REVISION INFORMATION.....	iv
ITEM CHECKLIST.....	iv
CHAPTER 1 INTRODUCTION OF THE MOTHERBOARD	
1-1 SPECIFICATION.....	1
1-2 LAYOUT DIAGRAM.....	2
CHAPTER 2 HARDWARE INSTALLATION	
2-1 JUMPER SETTING.....	6
2-2 CONNECTORS AND HEADERS.....	11
2-2-1 REAR I/O BACK PANEL CONNECTORS.....	11
2-2-2 MOTHERBOARD INTERNAL CONNECTORS.....	12
2-2-3 HEADER PIN DEFINITION.....	15
CHAPTER 3 INTRODUCING BIOS	
3-1 ENTERNING SETUP.....	20
3-2 BIOS MENU SCREEN.....	20
3-3 FUNCTION KEYS.....	21
3-4 GETTING HELP.....	21
3-5 MENU BARS.....	22
3-6 MAIN MENU.....	22
3-7 ADVANCED MENU.....	23
3-8 CHIPSET MENU.....	31
3-9 SECURITY MENU.....	33
3-10 BOOT MENU.....	33
3-11 SAVE & EXIT MENU.....	34



Environmental Safety Instruction

- Avoid the dusty, humidity and temperature extremes. Do not place the product in any area where it may become wet.
- 0 to 40 centigrade is the suitable temperature. (The figure comes from the request of the main chipset)
- Generally speaking, dramatic changes in temperature may lead to contact malfunction and crackles due to constant thermal expansion and contraction from the welding spots' that connect components and PCB. Computer should go through an adaptive phase before it boots when it is moved from a cold environment to a warmer one to avoid condensation phenomenon. These water drops attached on PCB or the surface of the components can bring about phenomena as minor as computer instability resulted from corrosion and oxidation from components and PCB or as major as short circuit that can burn the components. Suggest starting the computer until the temperature goes up.
- The increasing temperature of the capacitor may decrease the life of computer. Using the close case may decrease the life of other device because the higher temperature in the inner of the case.
- Attention to the heat sink when you over-clocking. The higher temperature may decrease the life of the device and burned the capacitor.

Environmental Protection Announcement

Do not dispose this electronic device into the trash while discarding. To minimize pollution and ensure environment protection of mother earth, please recycle.



USER'S NOTICE

COPYRIGHT OF THIS MANUAL BELONGS TO THE MANUFACTURER. NO PART OF THIS MANUAL, INCLUDING THE PRODUCTS AND SOFTWARE DESCRIBED IN IT MAY BE REPRODUCED, TRANSMITTED OR TRANSLATED INTO ANY LANGUAGE IN ANY FORM OR BY ANY MEANS WITHOUT WRITTEN PERMISSION OF THE MANUFACTURER.

THIS MANUAL CONTAINS ALL INFORMATION REQUIRED TO USE THIS MOTHER-BOARD SERIES AND WE DO ASSURE THIS MANUAL MEETS USER'S REQUIREMENT BUT WILL CHANGE, CORRECT ANY TIME WITHOUT NOTICE. MANUFACTURER PROVIDES THIS MANUAL "AS IS" WITHOUT WARRANTY OF ANY KIND, AND WILL NOT BE LIABLE FOR ANY INDIRECT, SPECIAL, INCIDENTAL OR CONSEQUENTIAL DAMAGES (INCLUDING DAMAGES FOR LOSS OF PROFIT, LOSS OF BUSINESS, LOSS OF USE OF DATA, INTERRUPTION OF BUSINESS AND THE LIKE).

PRODUCTS AND CORPORATE NAMES APPEARING IN THIS MANUAL MAY OR MAY NOT BE REGISTERED TRADEMARKS OR COPYRIGHTS OF THEIR RESPECTIVE COMPANIES, AND THEY ARE USED ONLY FOR IDENTIFICATION OR EXPLANATION AND TO THE OWNER'S BENEFIT, WITHOUT INTENT TO INFRINGE.

Manual Revision Information

Reversion	Revision History	Date
5.0	Fifth Edition	March 17, 2020

Item Checklist

- Motherboard
- Cable(s)
- I/O Back panel shield

Chapter 1

Introduction of the Motherboard

1-1 Specification

Spec	Description
Design	<ul style="list-style-type: none"> ● ATX form factor; PCB size: 30.5 x24.5 cm
Chipset	<ul style="list-style-type: none"> ● Intel® Q170 Express Chipset
LGA1155 CPU Socket	<ul style="list-style-type: none"> ● Supports Intel® Core™ i7, Core™ i5, Core™ i3 series, Pentium® processor in LAG1151 Package (Max. 65W TDP) <p><i>* for detailed CPU support information please visit our website</i></p>
Memory Slot	<ul style="list-style-type: none"> ● 4*DDR4 RAM module slot ● Supporting 4* 2133MHz DDR4 RAM Module, expandable to 64 GB (Maximum) ● Support dual-channel function
Expansion Slots	<ul style="list-style-type: none"> ● 1 * PCI-Express x16 slot (PCIE1, share with PCIE3 slot) ● 1 * PCI-Express x 8 slot (PCIE3, share with PCIE1 slot) ● 1 * PCI-Express x4 slot (PCIE6) ● 3 * PCI-Express x1 slot (PCIE2/4/5) ● 1 * Full-size Mini-PCIE slot (MPE)
Storage	<ul style="list-style-type: none"> ● 4 * SATAIII 6Gb/s port (SATA1/2/3/4) ● Support RAID 0, 1, 5, 10 function ● 1* M.2 Socket 3 connector (Socket 3, M-key, support type 2242/2260/2280/22110 SATA & PCIE x4 SSD, shares with SATA1, ME FW optional)
LAN Chip	<ul style="list-style-type: none"> ● Integrated with Intel i211AT Gigabit PCI-E LAN chip & Intel i219-LM Gigabit LAN PHY chip ● Support Fast Ethernet LAN function of providing 10/100/1000Mbps Ethernet data transfer rate
Audio Chip	<ul style="list-style-type: none"> ● Realtek ALC662 6-channel Audio Codec integrated ● Audio driver and utility included
BIOS	<ul style="list-style-type: none"> ● 128M Bit SMT Flash ROM
Multi I/O	<p>Rear Panel I/O:</p> <ul style="list-style-type: none"> ● 1*Serial port connector ● 1*DVI-D port connector ● 1* HDMI port connector ● 1* Display port connector ● 1* PS/2 keyboard & mouse combo port connector ● 2* RJ-45 LAN port connector ● 6* USB 3.0 port connector ● 1*3-jack audio connector (Line-in, Line-out, MIC) <p>Internal I/O Connectors & Headers:</p> <ul style="list-style-type: none"> ● 1 *24-pin main power connector ● 1 *8-pin 12V power connector

	<ul style="list-style-type: none"> ● 1* Front panel audio header ● 1* HDMI-SPDIF header ● 1* GPIO header ● 1* TPM 1.2 header ● 2* front panel USB 2.0 header (support 4* expansion USB 2.0 ports) ● 1* Front panel header ● 1* Speaker header+ 1* POWER LED header ● 1* SM_BUS header ● 2* LAN Status indicator header ● 9* COM port header (COM2/3/4/5/6/7/8/9/10, COM2 supports RS422/RS485 function) ● 3* FAN header
--	--

1-2 Layout Diagram

Rear IO Diagram

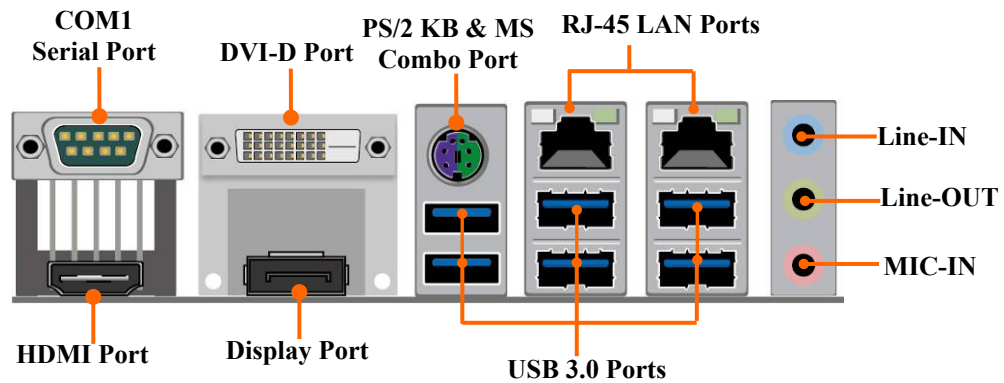

* **Note:** Many PCs now include XHCI USB controllers which allow for the support of USB 3.0 and higher USB speeds. This inclusion of XHCI controllers has lessened the need for EHCI USB controllers within platforms. However, legacy operating systems (OS) may not natively recognize XHCI controllers. You might need to pre-install XHCI driver while desiring to install a non-XHCI OS (ex. Windows* 7) on Intel platforms which do not include EHCI controllers. Please contact your representative for more details.

Motherboard Internal Diagram

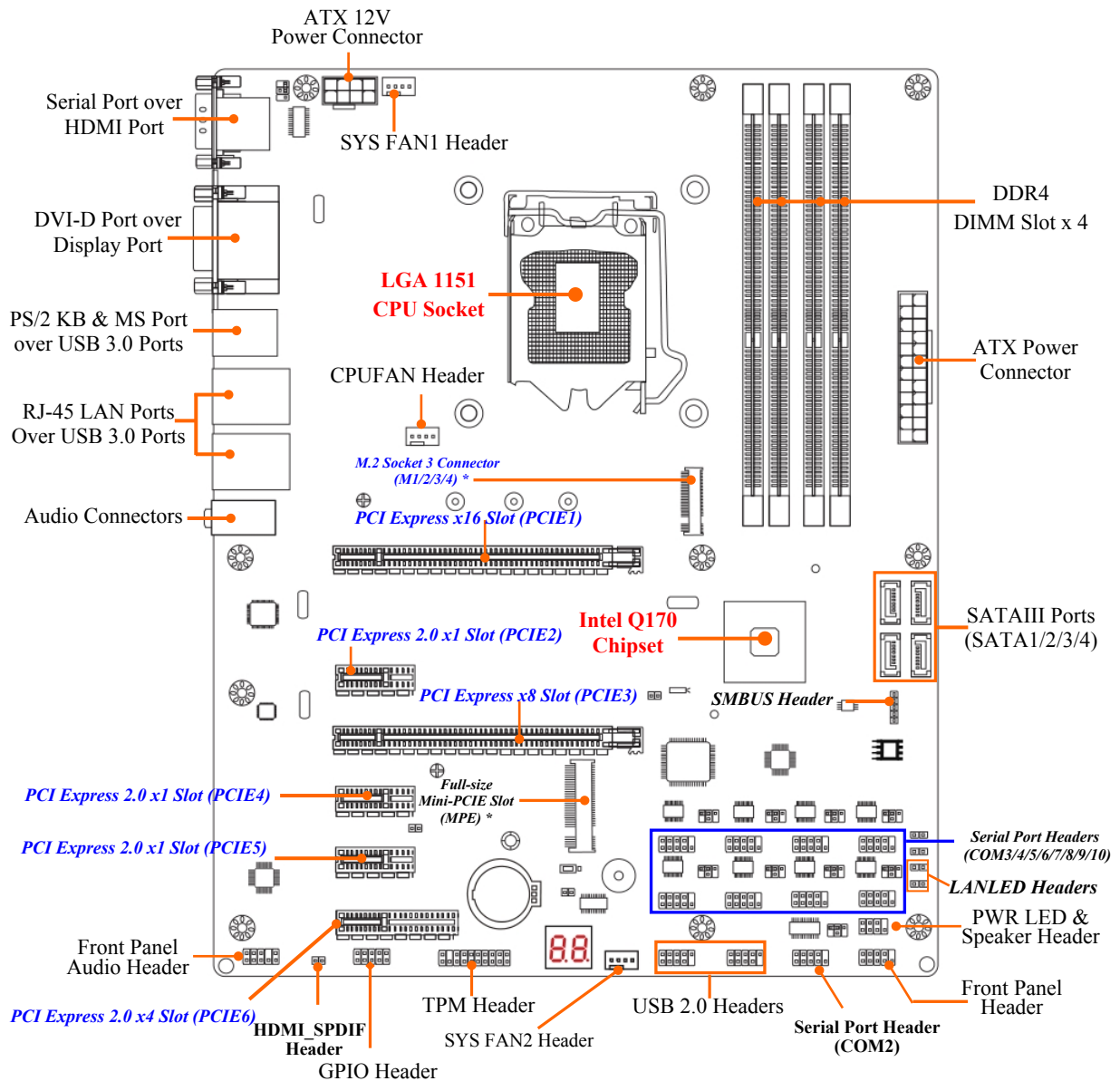

***Note: 1. PCI E1 slot shares function with PCI E3 slot, i.e. only one can function at a time.
 2. M.2 shares function with SATA1 port; user can only choose one to use at a time.**

Motherboard Jumper Positions

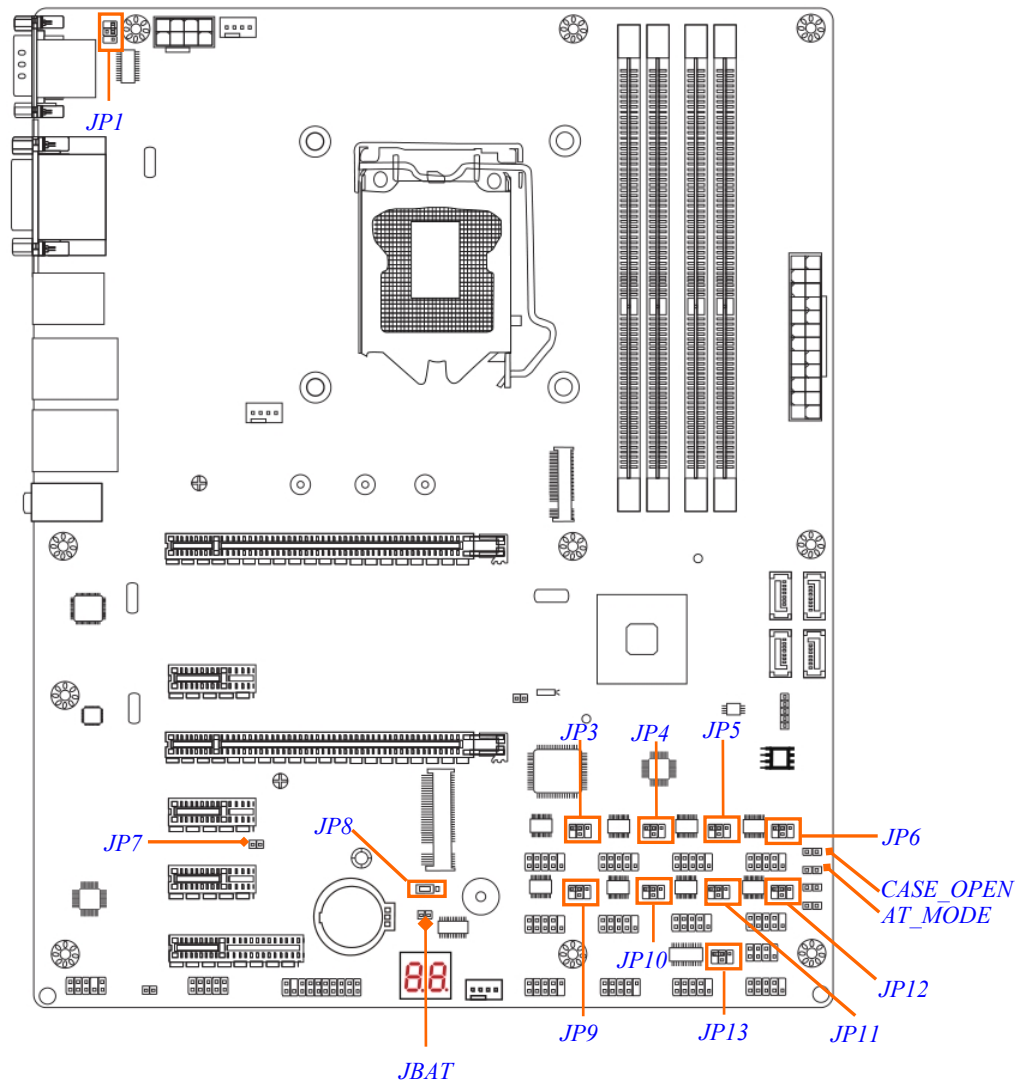

Jumper

Jumper	Name	Description
JP1	COM1 Port Pin9 Function Select	4-pin Block
JP13	COM2 Header Pin9 Function Select	4-pin Block
JP3	COM3 Header Pin9 Function Select	4-pin Block
JP4	COM5 Header Pin9 Function Select	4-pin Block
JP5	COM7 Header Pin9 Function Select	4-pin Block
JP6	COM9 Header Pin9 Function Select	4-pin Block
JP9	COM4 Header Pin9 Function Select	4-pin Block
JP10	COM6 Header Pin9 Function Select	4-pin Block
JP11	COM8 Header Pin9 Function Select	6-pin Block
JP12	COM10 Header Pin9 Function Select	6-pin Block
JP7	ME_Features Select	2-pin Block
JP8	Mini PCI-E Slot (MPE)VCC3.3V/3.3VSB Select	3-pin Block
JBAT	CMOS RAM Clear Function Setting	2-pin Block
Case_OPEN	Case Open Message Display Function Select	2-pin Block
AT_MODE	ATX/AT Mode Select	2-pin Block

Connectors

Connector	Name
ATXPWR	ATX Power Connector
ATX12V	ATX 12V Power Connector
COM1	Serial Port COM Connector
HDMI	High-Definition Multimedia Interface Connector
DVI	DVI-D Port Connector
DP	Display Port Connector
PS2_USB1	Top: PS/2 Keyboard & Mouse Combo Port Middle & Bottom: USB 3.0 Connector X2
UL1/UL2	Top: RJ-45 LAN Connector X2 Middle & Bottom: USB 3.0 Port Connector X2
AUDIO	Top: Line-in/Optical SPDIF-out Connector Middle: Line-out Connector Bottom: MIC Connector
SATA1/2/3/4	SATAIII Connector X4

Headers

Header	Name	Description
FP_AUDIO	Front Panel Audio Header	9-pin Block
HDMI_SPDIF	HDMI_SPDIF Out Header	2-pin Block
GPIO	GPIO Header	10-pin Block
TPM	TPM Header	19-pin Block
USB2/USB3	USB 2.0 Header	9-pin Block
COM 2/3/4/5/6/7/8/9/10	Serial Port Header	9-pin Block
FP (Front Panel Header)	PWR LED/ HD LED/ Power Button /Reset	9-pin Block
SPK_LED	Power LED & Speaker Header	7-pin Block
SM_BUS	SMBUS Header	5-pin Block
LAN1_LED1/ LAN2_LED	LANLED Activity Header	2-pin Block
SYSFAN1/SYSFAN2/CPUFAN	FAN Header	4-pin Block

Chapter 2 Hardware Installation

2-1 Jumper Setting

JP1 (4-pin): COM1 Port Pin9 Function Select

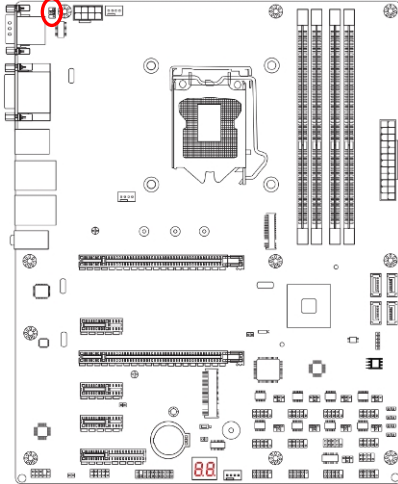

JP1 → COM1 Port



2-4 Closed:
RI=RS232;

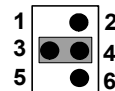

3-4 Closed:
RI= 5V;

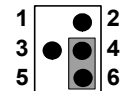

4-6 Closed:
RI= 12V;

JP13 (4-pin): COM2 Header Pin9 Function Select

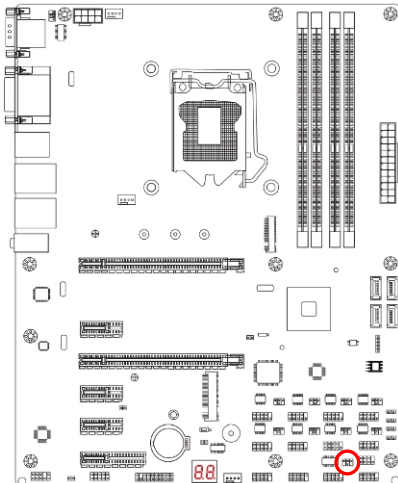

JP13 → COM2 Header

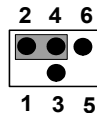

2-4 Closed:
RI=RS232;

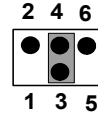

3-4 Closed:
RI= 5V;

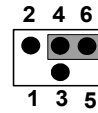

4-6 Closed:
RI= 12V;

JP3 (4-pin): COM3 Header Pin9 Function Select

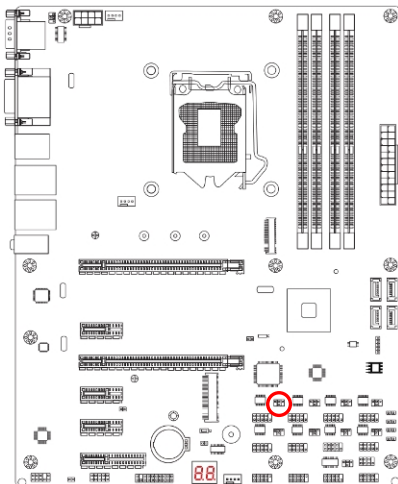

JP3 → COM3 Header

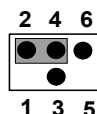

2-4 Closed:
RI=RS232;

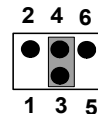

3-4 Closed:
RI= 5V;

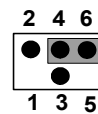

4-6 Closed:
RI= 12V;

JP4 (4-pin): COM5 Header Pin9 Function Select

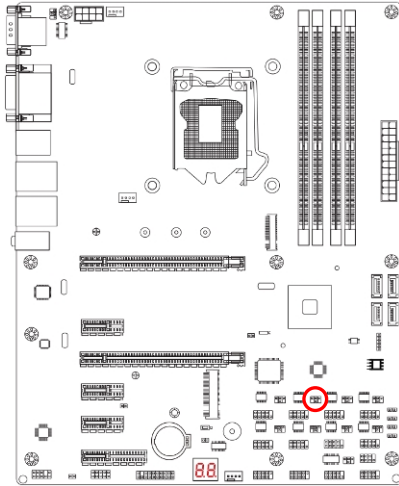

JP4 → COM5 Header

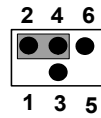

2-4 Closed:
RI=RS232;

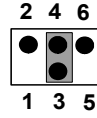

3-4 Closed:
RI= 5V;

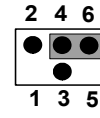

4-6 Closed:
RI= 12V;

JP5 (4-pin): COM7 Header Pin9 Function Select

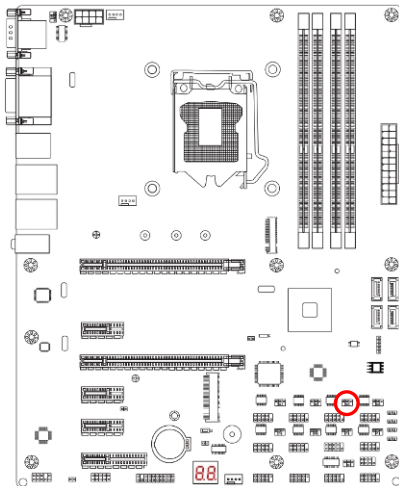

JP5 → COM7 Header

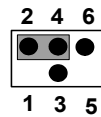

2-4 Closed:
RI=RS232;

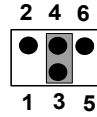

3-4 Closed:
RI= 5V;

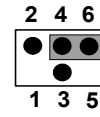

4-6 Closed:
RI= 12V;

JP6 (4-pin): COM9 Header Pin9 Function Select

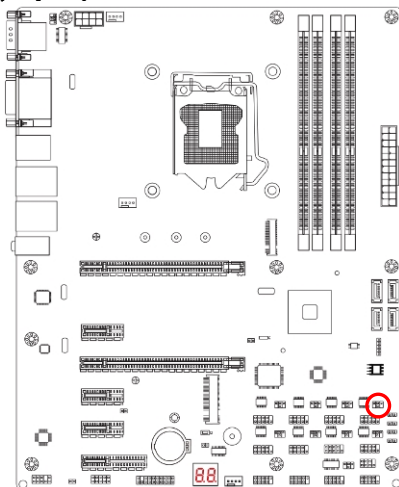

JP6 → COM9 Header

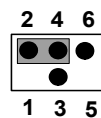

2-4 Closed:
RI=RS232;

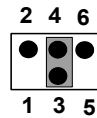

3-4 Closed:
RI= 5V;

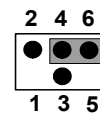

4-6 Closed:
RI= 12V;

JP9 (4-pin): COM4 Header Pin9 Function Select

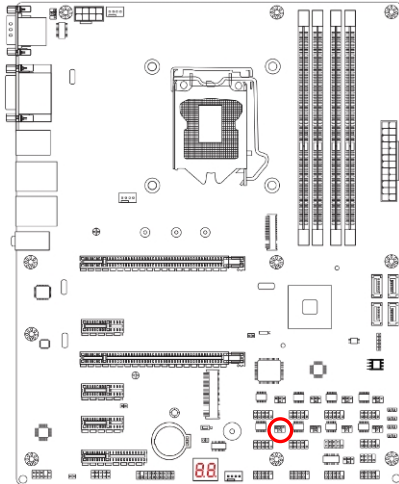

JP9 → COM4 Header

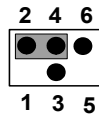

2-4 Closed:
RI=RS232;

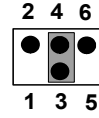

3-4 Closed:
RI= 5V;

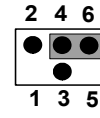

4-6 Closed:
RI= 12V;

JP10 (4-pin): COM6 Header Pin9 Function Select

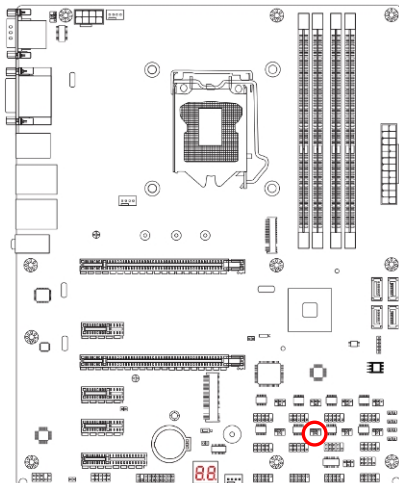

JP10 → COM6 Header

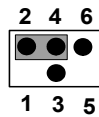

2-4 Closed:
RI=RS232;

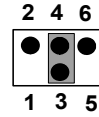

3-4 Closed:
RI= 5V;

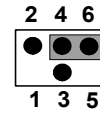

4-6 Closed:
RI= 12V;

JP11 (4-pin): COM8 Port Pin9 Function Select

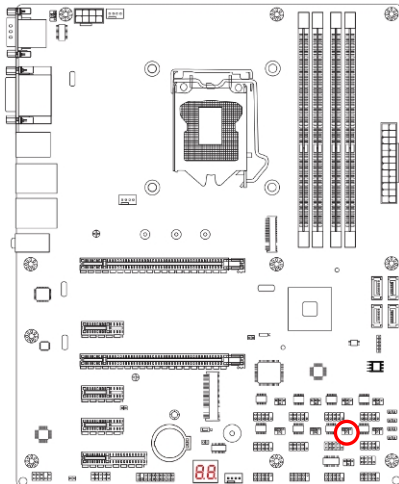

JP11 → COM8 Header

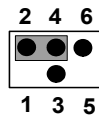

2-4 Closed:
RI=RS232;

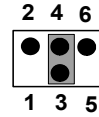

3-4 Closed:
RI= 5V;

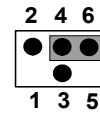

4-6 Closed:
RI= 12V;

JP12 (4-pin): COM10 Port Pin9 Function Select

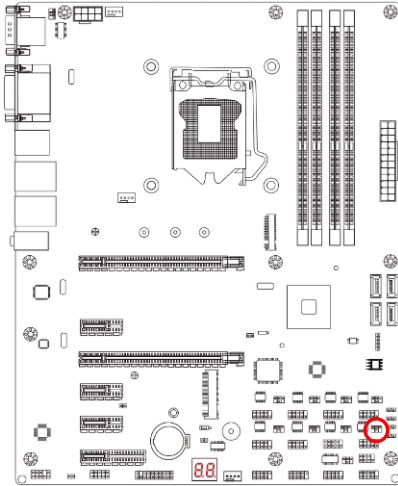

JP12→COM10 Header

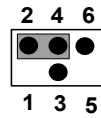

2-4 Closed:
RI=RS232;

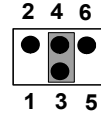

3-4 Closed:
RI= 5V;

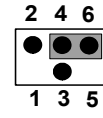

4-6 Closed:
RI= 12V;

JP7 (2-pin): ME Features Select

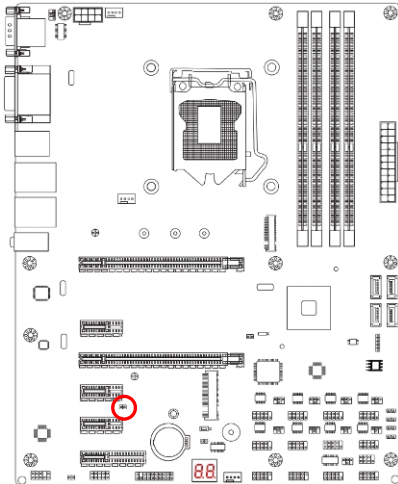

JP7→ME Features



1-2 Open:ME Features Enabled;



1-2 Closed:ME Features Disabled.

JP8 (3-pin): Mini PCI-E (MPE) Slot VCC 3.3V/3.3 VSB Select

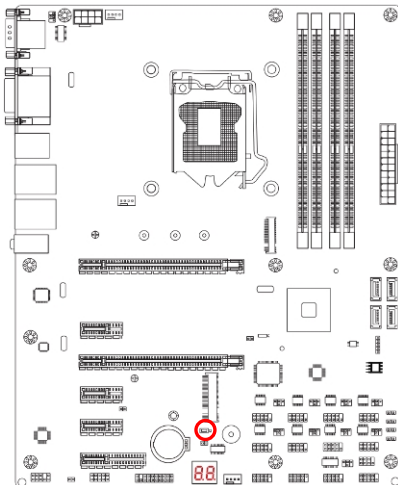

JP8→MPE Slot

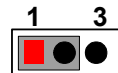

1-2 Closed: MINI PCI-E VCC= 3.3V;

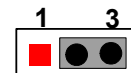

2-3 Closed: MINI PCI-E VCC= 3.3VSB.

JBAT (2-pin): Clear CMOS Function Settings

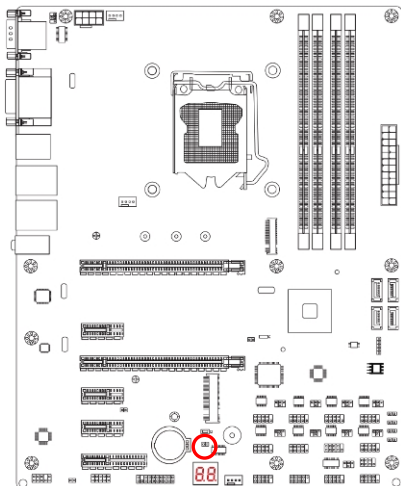

JBAT → Clear CMOS



Pin1

1-2 Open: Normal;



Pin1

1-2 Closed: Clear CMOS.

CASE_OPEN (2-pin): Case Open Message Display Function Select

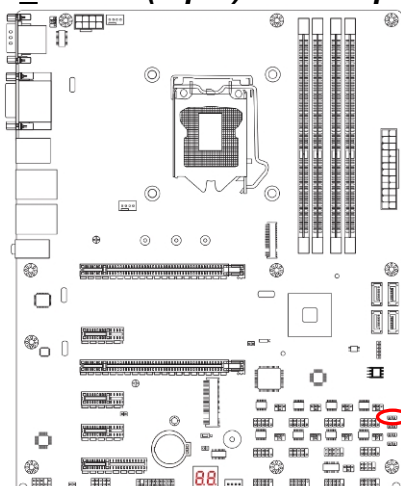

CASE_OPEN → Case Open Detection



Pin1

1-2 Open: Normal;



Pin1

1-2 Closed: Case Open Function Selected.

Pin 1-2 Closed: Case open display function enabled. Use needs to enter BIOS and enable 'Case Open Detect' function. In this case if you case is removed, next time when you restart your computer a message will be displayed onscreen to inform you of this.

AT_MODE (2-pin): AT Mode Function Select

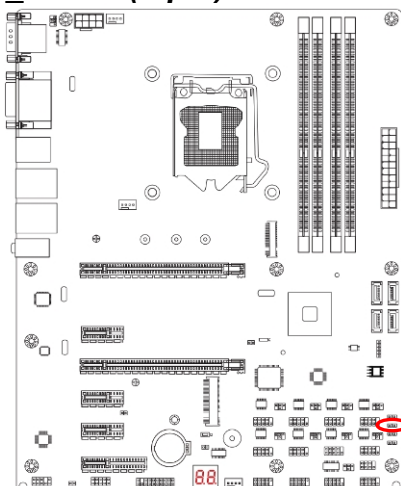

AT_MODE → AT/ATX Mode Select



Pin1

1-2 Open: ATX Mode Selected;



Pin1

1-2 Closed: AT Mode Selected.









***ATX Mode Selected:** Press power button to power on after power input ready;

AT Mode Selected: Directly power on as power input ready.

2-2 Connectors and Headers

2-2-1 Rear I/O Back Panel Connectors

**Refer to Page-2.*

Icon	Name	Function
	RS232/422/485 Serial Port	Mainly for user to connect external MODEM or other devices that supports Serial Communications Interface.
	DVI-D Port	To connect display device that support DVI specification (Max. resolution Support:1920*1080@60Hz).
	HDMI Port	To connect display device that support HDMI specification. (Max. resolution Support: 4096*2160@60Hz)
	Display Port	To the system to corresponding display device with compatible DP cable. (Max. resolution Support : 4096*2304@60Hz)
	PS/2 Mouse & Keyboard Combo Port	This combo port is for user to connect PS/2 mouse or keyboard device to the board.
	USB 3.0 Port	To connect USB keyboard, mouse or other devices compatible with USB specification. USB 3.0 ports supports up to 5Gbps data transfer rate.
	RJ-45 LAN Port	This connector is standard RJ-45 LAN jack for Network connection.
	Audio Connectors	BLUE: Line-in Connector GREEN: Line-out Connector PINK : MIC Connector

COM1 (9-pin Block): RS232/422/485 Port

COM1 port can function as RS232/422/485 port. In normal settings COM1 functions as RS232 port. With compatible COM cable COM1 can function as RS422 or RS 485 port.

User also needs to go to BIOS to set '**Transmission Mode Select**' for COM1 (*refer to Page 25*) at first, before using specialized cable to connect different pins of this port.

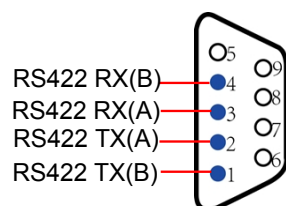

For RS422 Mode

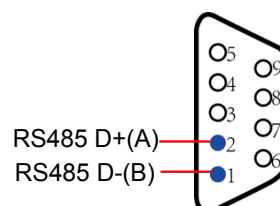

For RS485 Mode

2-2-2 Motherboard Internal Connectors

(1) ATXPWR (24-pin block): Main Power Connector

ATX Power Supply connector: This is a new defined 24-pins connector that usually comes with ATX case. The ATX Power Supply allows using soft power on momentary switch that connect from the front panel switch to 2-pins Power On jumper pole on the motherboard. When the power switch on the back of the ATX power supply turned on, the full power will not come into the system board until the front panel switch is momentarily pressed. Press this switch again will turn off the power to the system board.

- ** We recommend that you use an ATX 12V Specification 2.0-compliant power supply unit (PSU) with a minimum of 350W power rating. This type has 24-pin and 4-pin power plugs.
- ** If you intend to use a PSU with 20-pin and 4-pin power plugs, make sure that the 20-pin power plug can provide at least 15A on +12V and the power supply unit has a minimum power rating of 350W. The system may become unstable or may not boot up if the power is inadequate.
- ** If you are using a 20-pin power plug, please refer to Figure1 for power supply connection. Power plug form power supply and power connectors from motherboard both adopt key design to avoid mistake installation. You can insert the power plug into the connector with ease only in the right direction. If the direction is wrong it is hard to fit in and if you make the connection by force if is possible.

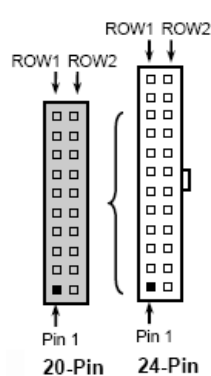
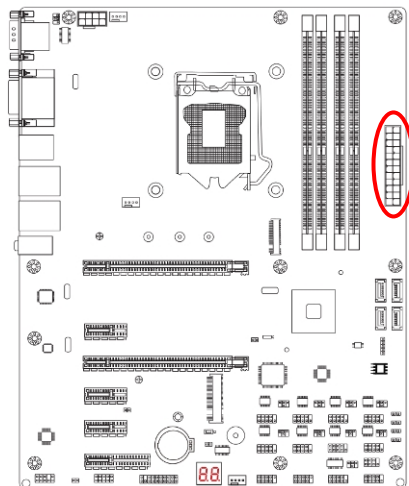

PIN	ROW1	ROW2
1	+3.3V	+3.3V
2	+3.3V	-12V
3	GND	GND
4	+5V	Soft Power on
5	GND	GND
6	+5V	GND
7	GND	GND
8	Power OK	-5V
9	+5V Stand by	+5V
10	+12V	+5V
11	+12V	+5V
12	+3.3V	GND

24-pin Main Power Connector

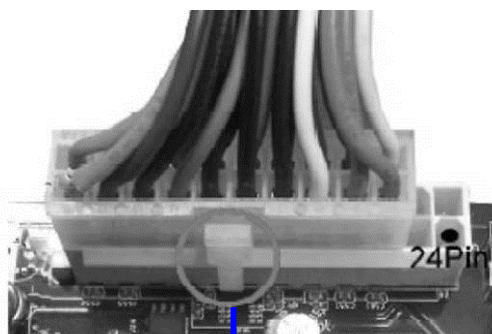

Figure1: 20-pin power plug

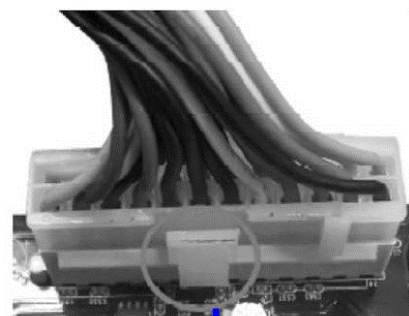

Figure 2: 24-pin power plug

(2) ATX12V (8-pin block): 12V Power Connector

This is a new defined 8-pin connector that usually comes with ATX Power Supply that supports extra 12V voltage to maintain system power consumption. Without this connector might cause system unstable because the power supply can not provide sufficient current for system.

Pin	Definition	No.	Definition
1	GND	5	+12V
2	GND	6	+12V
3	GND	7	+12V
4	GND	8	+12V

(3) SATA1/2/3/4: SATAIII Port Connector

These connectors are high-speed SATAIII ports that support 6 GB/s transfer rate.

Pin No.	Definition
1	GND
2	TXP
3	TXN
4	GND
5	RXN
6	RXP
7	GND

(4) M2: M2 Socket 3 Connector

This M2 Socket 3 connector support compatible type 2242/2260/2280/22110 SATA & PCIE x4 SSD module.

M2 Socket 3 Connector

**Note: M2 shares with SATA1, i.e., only one can function at a time.*

M.2 Module Installation Guide



1. Prepare compatible M.2 SATA or M.2 SSD card. Deferent type of cards has different length. Find corresponding nut location for further installation.

Nut Location	MH1	MH2	MH3	MH4
Card Length	4.2 cm	6 cm	8 cm	11 cm
Module Type	Type 2242	Type 2260	Type 2280	Type 22110



2. Remove the screw post and nut fixed at location **MH4** by default (Skip step 2 & 3 and go straight to Step 4 if you are going to use the default nut).



3. Lock the screw post into the location corresponding to the length of the module.

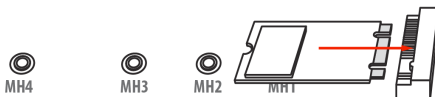

4. Align and insert corresponding M.2 module, as the photo shows.

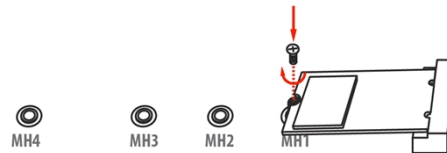

5. Tighten up the screw to secure the module into the M.2 connector. Mare sure not overtighten the screw to avoid possible damage to the module.

2-2-3 Header Pin Definition

(1) FP_AUDIO (9-pin): Line-Out, MIC-In Header

This header is connected to Front Panel Line-out, MIC connector with cable.

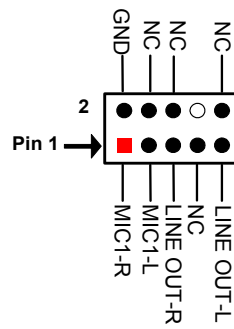
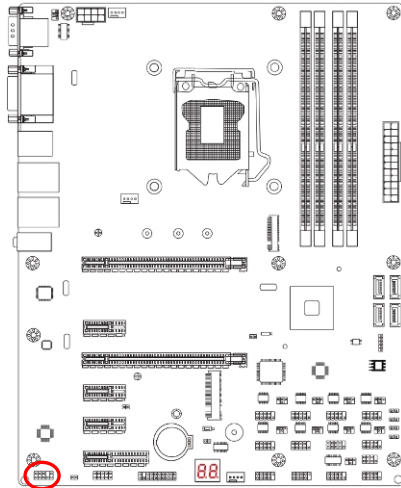

(2) HDMI_SPDIF (2-pin): HDMI-SPDIF Out header

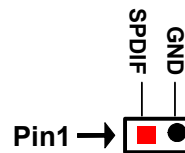
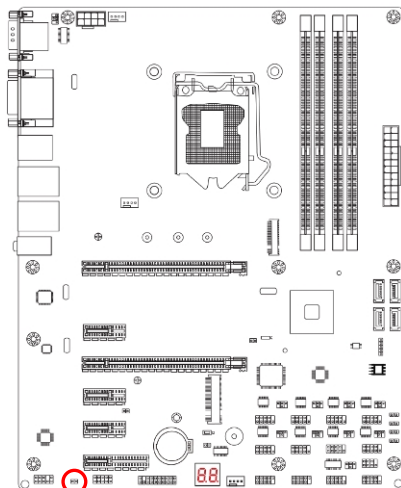

(3) GPIO (10-pin): GPIO Header

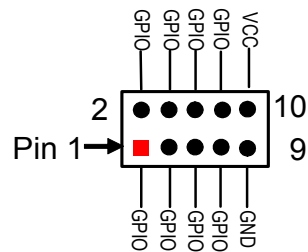
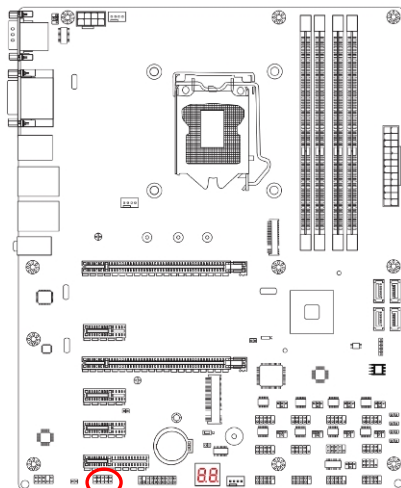

(4) TPM (19-pin): TPM Header

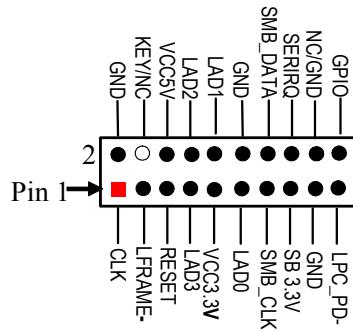
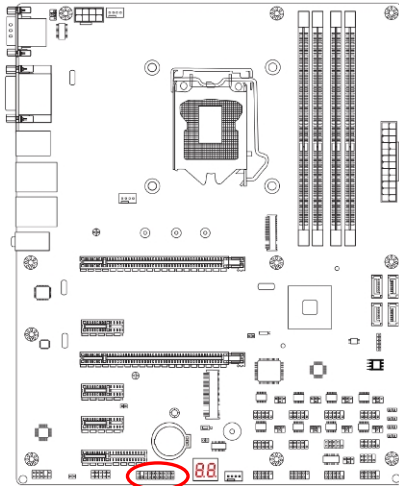

(5) USB 2.0 Port Headers (9-pin): USB3/USB4

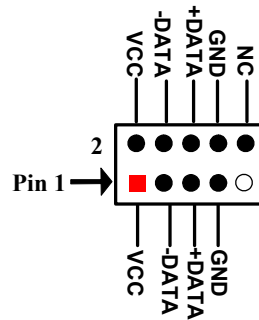
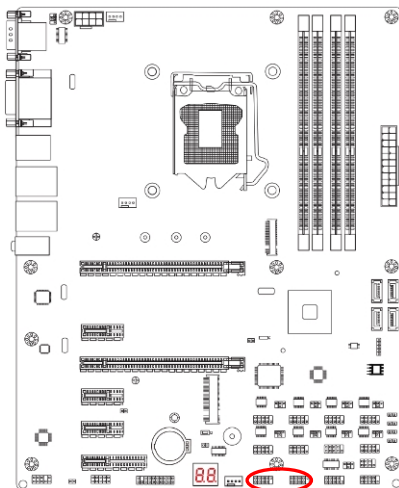

(6) FP (9-pin): Front Panel Header

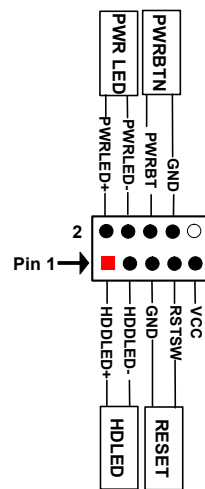
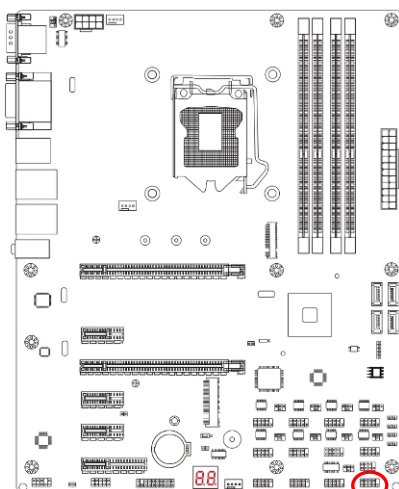

(7) SPK_LED(7-pin): PWR LED Header & Speaker Header

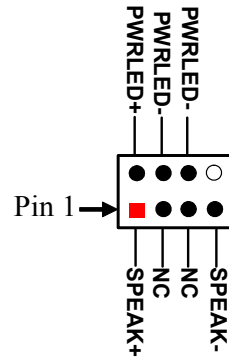
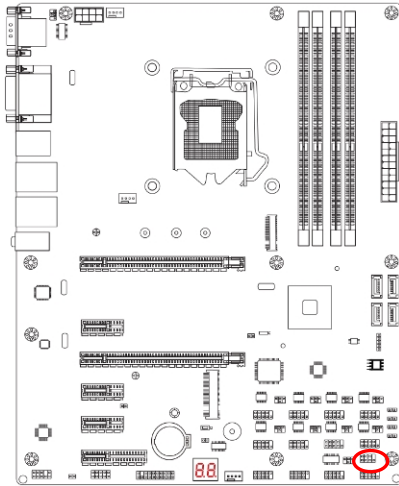

(8) SM_BUS (5-pin): SM BUS Header

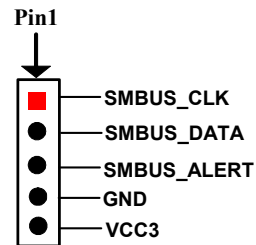
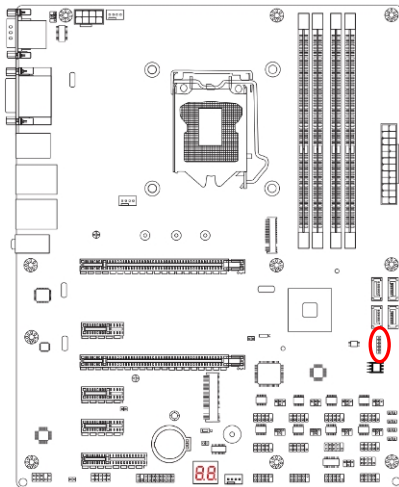

(9) LAN1_LED/ LAN2_LED (2-pin): LANLED Header

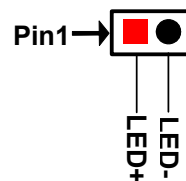
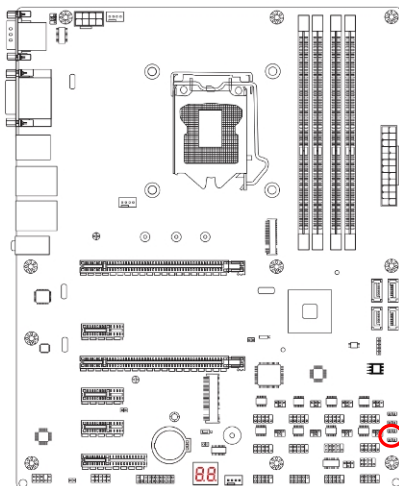

(10) COM2/3/4/5/6/7/8/9/10 (9-pin): Serial Port Header

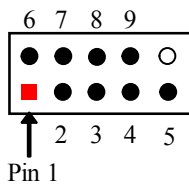
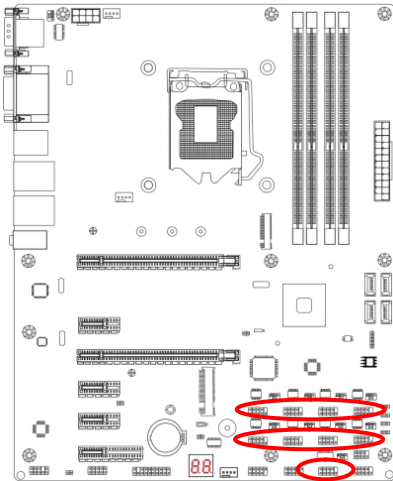

Pin NO.	RS232	*RS422 <i>(optional)</i>	*RS485 <i>(optional)</i>
Pin 1	DCD	TX-	DATA-
Pin 2	RXD	TX+	DATA+
Pin 3	TXD	RX+	NC
Pin 4	DTR	RX-	NC
Pin 5	GND	GND	GND
Pin 6	DSR	NC	NC
Pin 7	RTS	NC	NC
Pin 8	CTS	NC	NC
Pin 9	RI	NC	NC

***Notice:** COM2 header can function as RS232/422/485 port header. In normal settings COM2 functions as RS232 header. With compatible COM cable COM2 can function as RS422 or RS 485 header. User also needs to go to BIOS to set 'Transmission Mode Select' for COM2 (refer to Page-24) at first, before using specialized cable to connect different pins of this port.

(11) SYSFAN1/CPUFAN/SYSFAN2 (4-pin): FAN Headers

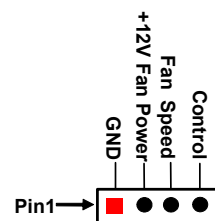
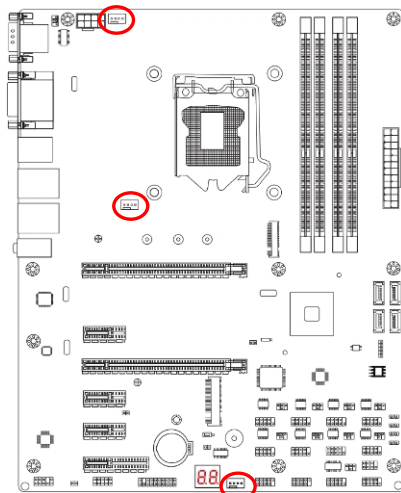

CPUFAN/SYSFAN1/SYSFAN2

(12) Dual Channel Memory Installation

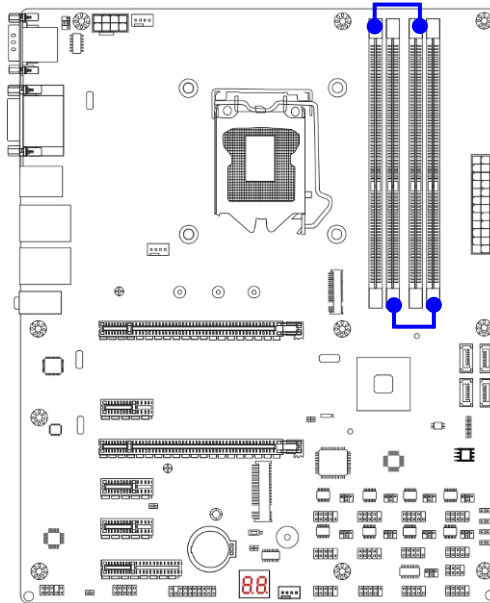

Config.	Slot 1	Slot 2	Slot 3	Slot 4
1	install	--	install	--
2	--	install	--	install
3	install	install	install	install

Notice!

- For dual channel installation, you need to install the same brand, speed, size and type memory module.
- It is unable to activate dual channel feature if you install one or three memory modules, or you install slot 1 & slot 4 / slot 2 & slot 3. Slot order can be from left-to-right or right-to-left, and it must be installed in pairs.
- If you install memory modules in wrong direction, it will damage the motherboard and memory module.

Chapter 3

Introducing BIOS

Notice! The BIOS options in this manual are for reference only. Different configurations may lead to difference in BIOS screen and BIOS screens in manuals are usually the first BIOS version when the board is released and may be different from your purchased motherboard. Users are welcome to download the latest BIOS version form our official website.

The BIOS is a program located on a Flash Memory on the motherboard. This program is a bridge between motherboard and operating system. When you start the computer, the BIOS program will gain control. The BIOS first operates an auto-diagnostic test called POST (power on self test) for all the necessary hardware, it detects the entire hardware device and configures the parameters of the hardware synchronization. Only when these tasks are completed done it gives up control of the computer to operating system (OS). Since the BIOS is the only channel for hardware and software to communicate, it is the key factor for system stability, and in ensuring that your system performance as its best.

3-1 Entering Setup

Power on the computer and by pressing immediately allows you to enter Setup. If the message disappears before your respond and you still wish to enter Setup, restart the system to try again by turning it OFF then ON or pressing the “RESET” button on the system case. You may also restart by simultaneously pressing <Ctrl>, <Alt> and <Delete> keys. If you do not press the keys at the correct time and the system does not boot, an error message will be displayed and you will again be asked to

Press to enter Setup

3-2 BIOS Menu Screen

The following diagram show a general BIOS menu screen:

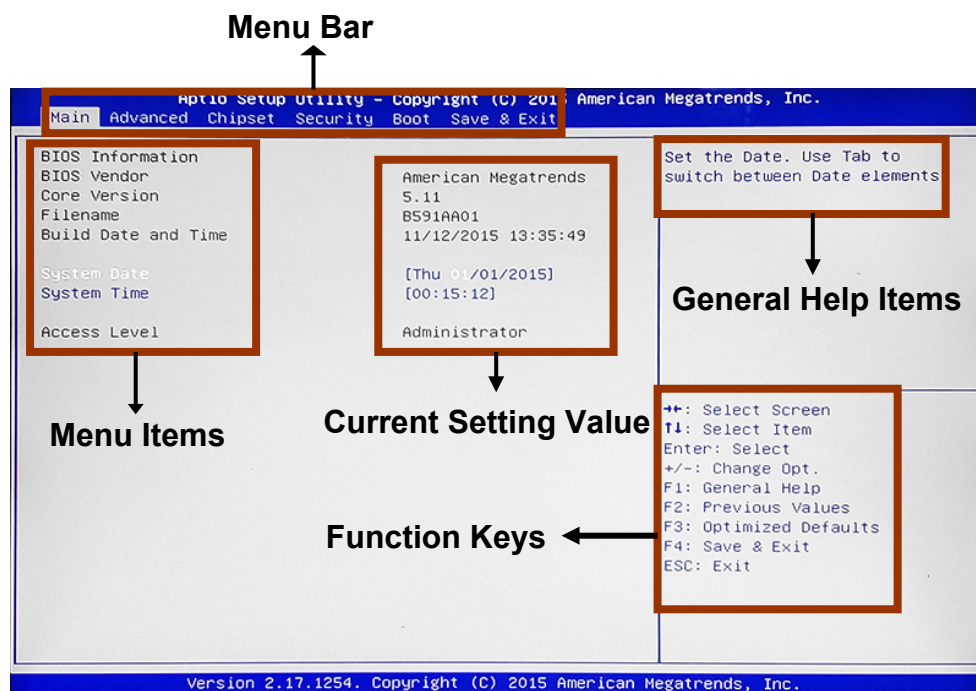

BIOS Menu Screen

3-3 Function Keys

In the above BIOS Setup main menu of, you can see several options. We will explain these options step by step in the following pages of this chapter, but let us first see a short description of the function keys you may use here:

- Press ←→ (left, right) to select screen;
- Press ↑↓ (up, down) to choose, in the main menu, the option you want to confirm or to modify.
- Press <Enter> to select.
- Press <+>/<-> keys when you want to modify the BIOS parameters for the active option.
- [F1]: General help.
- [F2]: Previous value.
- [F3]: Optimized defaults.
- [F4]: Save & Exit.
- Press <Esc> to quit the BIOS Setup.

3-4 Getting Help

Main Menu

The on-line description of the highlighted setup function is displayed at the top right corner the screen.

Status Page Setup Menu/Option Page Setup Menu

Press F1 to pop up a small help window that describes the appropriate keys to use and the possible selections for the highlighted item. To exit the Help Window, press <Esc>.

3-5 Menu Bars

There are six menu bars on top of BIOS screen:

Main	To change system basic configuration
Advanced	To change system advanced configuration
Chipset	To change chipset configuration
Security	Password settings
Boot	To change boot settings
Save & Exit	Save setting, loading and exit options.

User can press the right or left arrow key on the keyboard to switch from menu bar. The selected one is highlighted.

3-6 Main Menu

Main menu screen includes some basic system information. Highlight the item and then use the <+> or <-> and numerical keyboard keys to select the value you want in each item.

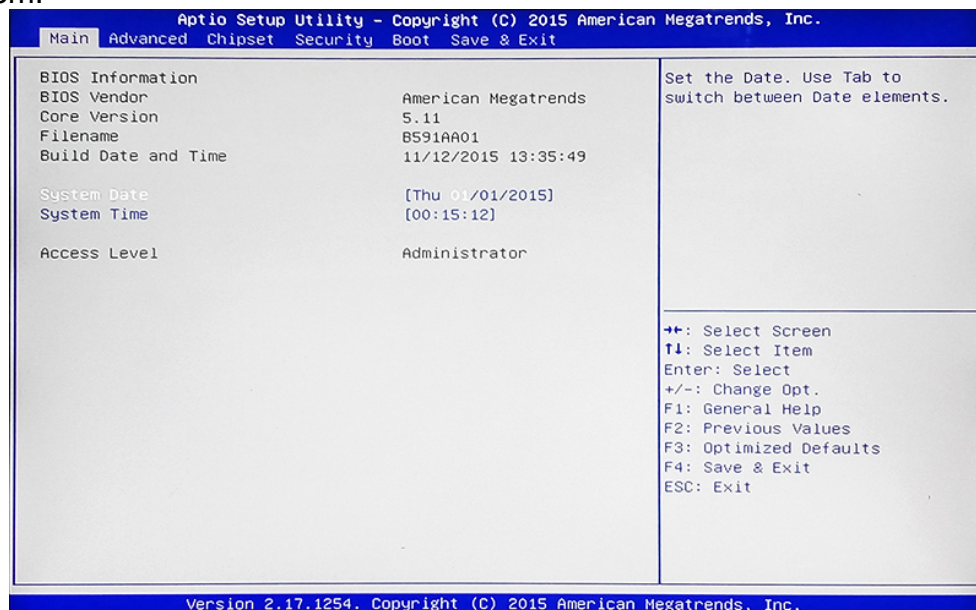

System Date

Set the date. Please use [Tab] to switch between data elements.

System Time

Set the time. Please use [Tab] to switch between time elements.

3-7 Advanced Menu

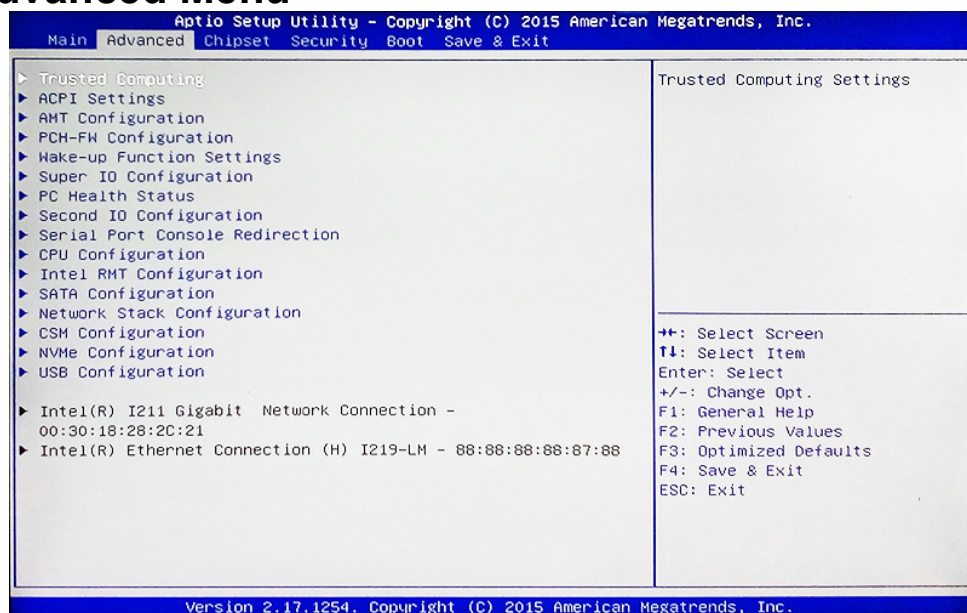

▶ **Trusted Computing**

Press [Enter] to enable or disable 'Security Device Support'.

Security Device Support

Use this item to enable or disable BIOS support for security device. TCG EFI protocol and INT1A interface will not be available.

The optional settings: [Disabled]; [Enabled].

▶ **ACPI Settings**

Press [Enter] to make settings for the following sub-items:

ACPI Settings

ACPI Sleep State

Use this item to select the highest ACPI sleep state the system will enter when the suspend button is pressed.

The optional settings are: [Suspend Disabled]; [S3 only (Suspend to RAM)].

▶ **AMT Configuration**

Use this item to configure Active Management Technology parameters.

Press [Enter] to make settings for the following sub-items:

Intel AMT

Use this item to enable or disable Intel Active Management Technology BIOS extension.

Hide Un-Configure ME Confirmation Prompt

Use this function to enable or disable Hide Un-Configure ME without password Configuration Prompt function.

MEBx Debug Message Output

Use this function to enable or disable MEBx Debug Message Output function.

Un-Configure ME

Use this function to enable or disable Un-Configure ME without password function.

Amt Wait Timer

Use this item to set time to wait before sending ASF_GET_BOOT_OPTIONS.

ASF

Use this item to enable or disable Alert Specification Format.

Activate Remote Assistance Process

Use this item to enable or disable Trigger CIRA boot function.

USB Configure

Use this item to enable or disable USB configure function.

PET Progress

Use this item to enable or disable PET events progress to receive PET events or not.

WatchDog

Use this item to enable or disable WatchDog Timer. When set as [Enabled], the following sub-items shall appear:

OS Timer

Use this item to set OS watch dog timer.

BIOS Timer

Use this item to set BIOS watch dog timer.

▶ **PCH-FW Configuration**

Press [Enter] to view ME information and make settings in the following sub-items:

TPM Device Selection

Use this item to select TPM device.

The optional settings: [dTPM1.2]; [PTT].

[PTT]: Enable PTT in SkuMgr.

[Disabled]: Disable PTT in SkuMgr.

*Warning: PTT/dTPM will be disabled and all data saved on it will be lost.

▶ **Firmware Update Configuration**

Press [Enter] to make settings for ME FW Image Re-Flash.

ME FW Image Re-Flash

Use this item to enable or disable ME FW Image Re-Flash function.

The optional settings: [Disabled]; [Enabled].

** In the case that user needs to update ME firmware, user should set 'ME FW Image Re-Flash' as [Enabled], save the settings and exit. The system will turn off and reboot after 4 seconds. If the user goes to BIOS screen again will find this item is set again as [Disabled], but user can still re-flash to update firmware next time.*

▶ **Wakeup Function Settings**

Press [Enter] to make settings for the following sub-items:

Wake-up System with Fixed Time

Use this item to enable or disable system wake on alarm event.

The optional settings: [Disabled]; [Enabled].

When set as [Enabled], system will wake on the hour/min/sec specified.

Wake-up System with Dynamic Time

Use this item to enable or disable system wake-up by RTC alarm.

The optional settings: [Disabled]; [Enabled].

When set as [Enabled], system will wake on the current time + increased minute(s).

USB S3/S4 Wake-up

Use this item to enable or disable USB S3/S4 wakeup. This function is only supported when ERP function is disabled.

USB S5 Power

Use this item to enable or disable USB power in S5 state.

PS2 KB/MS Wake-up

The optional settings: [Enabled]; [Disabled].

Use this item to enable or disable PS2 KB/MS wake-up from S3(/S4/S5).

**This function is supported when ErP Function is set as [Disabled].*

Ring Wake-up

The optional settings: [Enabled]; [Disabled].

Use this item to enable or disable Ring Wakeup.

▶ **Super I/O Configuration**

Press [Enter] to make settings for the following sub-items:

Super IO Configuration

ERP Function

The optional settings:[Disabled]; [Auto].

This item should be set as [**Disabled**] if you wish to have all active wake-up functions.

▶ **Serial Port 1 Configuration/Serial Port 2 Configuration**

Press [Enter] to make settings for the following items:

Serial Port

Use this item to enable or disable serial port (COM).

Change Settings

Use this item to select an optimal setting for super IO device.

Transmission Mode Select

The optional settings are: [RS422]; [RS232]; [RS485].

Mode Speed Select

The optional settings are: [RS232/RS422/RS485=250kbps]; [RS232=1Mbps, RS422/RS485=10Mbps].

Serial Port FIFO Mode

The optional settings are: [16-Byte FIFO]; [32-Byte FIFO]; [64-Byte FIFO]; [128-Byte FIFO].

▶ **Serial Port 3 Configuration/Serial Port 4 Configuration/Serial Port 5 Configuration/Serial Port 6 Configuration**

Press [Enter] to make settings for the following sub-items:

Serial Port

Use this item to enable or disable serial port (COM).

Change Settings

Use this item to select an optimal setting for super IO device.

Serial Port FIFO Mode

The optional settings are: [16-Byte FIFO]; [32-Byte FIFO]; [64-Byte FIFO]; [128-Byte FIFO].

WatchDog Reset Timer

Use this item to enable or disable WDT reset function. When set as [Enabled], the following sub-items shall appear:

WatchDog Reset Timer Value

User can set a value in the range of [4] to [255].

WatchDog Reset Timer Unit

The optional settings are: [Sec.]; [Min.].

WatchDog Wake-up Timer in ERP

This item support WDT wake-up while 'ERP Support' is set as [Auto].

The optional settings are: [Enabled]; [Disabled].

When set as [Enabled], the following sub-items shall appear:

WatchDog Wake-up Timer Value in ERP

User can select a value in the range of [10] to [4095] seconds when 'WatchDog Reset Timer Unit' set as [Sec]; or in the range of [1] to [4095] minutes when 'WatchDog Reset Timer Unit' set as [Min].

WatchDog Reset Timer Unit

The optional settings are: [Sec.]; [Min.].

ATX Power Emulate AT Power

This item support Emulate AT power function, MB power On/Off control by power supply. Use needs to select 'AT or ATX Mode' on MB jumper at first (refer to **Page 10**, AT_MODE jumper for ATX Mode & AT Mode Select).

Case Open Detect

Use this item to detect case has already open or not, show message in POST.

PS2 KB/MS Connect

Use this item to select PS2 connect primary device.

The optional settings are: [Keyboard First]; [Mouse First].

▶ **PC Health Status**

Press [Enter] to view current hardware health status, make further settings in 'SmartFAN Configuration' and set value in 'Shutdown Temperature'.

▶ **SmartFAN Configuration**

Press [Enter] to make settings for SmartFan Configuration:

SmartFAN Configuration

CPUFAN / SYSFAN1/ SYSFAN2 Smart Mode

The optional settings are: [Disabled]; [Enabled].

When set as [Enabled], the following sub-items shall appear:

CPUFAN / SYSFAN1/ SYSFAN2 Full-Speed Temperature

Use this item to set CPUFAN (/SYSFAN1/SYSFAN2) full speed temperature. Fan will run at full speed when above this pre-set temperature.

CPUFAN / SYSFAN1/ SYSFAN2 Full-Speed Duty

Use this item to set CPUFAN (/SYSFAN1/SYSFAN2) full-speed duty. Fan will run at full speed when above this pre-set duty.

CPUFAN / SYSFAN1/ SYSFAN2 Idle-Speed Temperature

Use this item to set CPUFAN (/SYSFAN1/SYSFAN2) idle speed temperature. Fan will run at idle speed when below this pre-set temperature.

CPUFAN / SYSFAN1/ SYSFAN2 Idle-Speed Duty

Use this item to set CPUFAN (/SYSFAN1/SYSFAN2) idle speed duty. Fan will run at idle speed when below this pre-set duty.

Shutdown Temperature

Use this item to select system shutdown temperature.

The optional settings are: [Disabled]; [70°C/156°F]; [75°C/164°F]; [80°C/172°F]; [85°C/180°F]; [90°C/188°F].

▶ **Second Super IO Configuration**

Second Super IO Configuration

▶ **Serial Port 7 Configuration/Serial Port 8 Configuration/Serial Port 9 Configuration/Serial Port 10 Configuration**

Press [Enter] to make settings for the following sub-items:

Serial Port

Use this item to enable or disable serial port (COM).

Change Settings

Use this item to select an optimal setting for super IO device.

▶ **Serial Port Console Redirection**

Press [Enter] to make settings for the following sub-items:

COM1

Console Redirection

Use this item to enable or disable COM1 Console Redirection.

The optional settings are: [Disabled]; [Enabled].

When set as [Enabled], user can make further settings in the 'Console Redirection Settings' screen:

▶ **Console Redirection Settings**

The settings specify how the host computer and the remote computer (which the user is using) will exchange data. Both computers should have the same or compatible settings.

Press [Enter] to make settings for the following sub-items.

Terminal Type

The optional settings are: [VT100]; [VT100+]; [VT-UTF8]; [ANSI].

Bits per second

The optional settings are: [9600]; [19200]; [38400]; [57600]; [115200].

Data Bits

The optional settings are: [7]; [8].

Parity

The optional settings are: [None]; [Even]; [Odd]; [Mark]; [Space].

Stop Bits

The optional settings are: [1]; [2].

Flow Control

The optional settings are: [None]; [Hardware RTS/CTS].

VT-UTF8 Combo Key Support

The optional settings are: [Disabled]; [Enabled].

Recorder Mode

The optional settings are: [Disabled]; [Enabled].

Resolution 100x31

The optional settings are: [Disabled]; [Enabled].

Legacy OS Redirection Resolution

The optional settings are: [80x24]; [80x25].

Putty Keypad

The optional settings are: [VT100]; [LINUX]; [XTERMR6]; [SCO]; [ESCN]; [VT400].

Redirection After BIOS POST

The optional settings are: [Always Enable]; [BootLoader].

Serial Port for Out-of-Band Management/

Windows Emergency Management Services (EMS)

Console Redirection

The optional settings: [Disabled]; [Enabled].

When set as [Enabled], user can make further settings in '**Console Redirection Settings**' screen:

▶ **Console Redirection Settings**

The settings specify how the host computer and the remote computer (which the user is using) will exchange data. Both computers should have the same or compatible settings.

Press [Enter] to make settings for the following sub-items.

Out-of-Band Mgmt Port

The optional settings are: [COM1]; [COM1(Pci Bus0, Dev0, Func0) (Disabled)].

Terminal Type

The optional settings are: [VT100]; [VT100+]; [VT-UTF8]; [ANSI].

Bits per second

The optional settings are: [9600]; [19200]; [57600]; [115200].

Flow Control

The optional settings are: [None]; [Hardware RTS/CTS]; [Software Xon/Xoff].

Data Bits

The default setting is: [8].

**This item may or may not show up, depending on different configuration.*

Parity

The default setting is: [None].

**This item may or may not show up, depending on different configuration.*

Stop Bits

The default setting is: [1].

**This item may or may not show up, depending on different configuration.*

▶ **CPU Configuration**

Press [Enter] to view current CPU configuration and make settings for the following sub-items:

Intel Virtualization Technology

The optional settings: [Enabled]; [Disabled].

When set as [Enabled], a VHM can utilize the additional hardware capabilities provided by Vanderpool Technology.

Hardware Prefetcher

Use this item to turn on/off the MLC streamer prefetcher.

The optional settings: [Disabled]; [Enabled].

Adjacent Cache Line Prefetch

Use this item to turn on/off prefetching of adjacent cache lines.

The optional settings: [Disabled]; [Enabled].

Intel(R) SpeedStep(tm)

The optional settings: [Disabled]; [Enabled].

When set as [Enabled], it allows more than two frequency ranges to be supported.

CPU C Status

Use this item to enable or disable CPU C status.

The optional settings: [Disabled]; [Enabled].

Package C State Limit

The optional settings are: [C0/C1]; [C2]; [C3]; [C6]; [C7]; [C7s]; [C8]; [AUTO].

► **Intel RMT Configuration**

Press [Enter] to go to next screen to enable or disable 'Intel Ready Mode Technology'.

Intel Ready Mode Technology

The optional settings: [Disabled]; [Enabled].

**When set as [Enabled], user can also make further settings in the following items that appear:*

Intel RMT State

Use this item to enable or disable Intel RMT enabling status in BIOS.

► **SATA Configuration**

Press [Enter] to make settings for the following sub-items:

SATA Controller(s)

The optional settings: [Disabled]; [Enabled].

SATA Mode Selection

The optional settings are: [AHCI]; [RAID].

SATA1/ mSATA

Port

The optional settings: [Disabled]; [Enabled].

Use this item to enable or disable device connected to SATA1 or mSATA.

SATA2/3/4/5/6

Port

The optional settings: [Disabled]; [Enabled].

Use this item to enable or disable each SATA port.

Hot Plug

The optional settings: [Disabled]; [Enabled].

**Note: mSATA does not support Hot Plug function!*

► **Network Stack Configuration**

Press [Enter] to go to 'Network Stack' screen to make further settings.

Network Stack

Use this item to enable or disable UEFI Network Stack.

The optional settings: [Disabled]; [Enabled].

When set as [Enabled], the following sub-items shall appear:

Ipv4 PXE Support

The optional settings are: [Disabled]; [Enabled].

Use this item to enable Ipv4 PXE Boot Support. When set as [Disabled], Ipv4 boot option will not be created.

Ipv6 PXE Support

The optional settings are: [Disabled]; [Enabled].

Use this item to enable Ipv6 PXE Boot Support. When set as [Disabled], Ipv6 boot optional will not be created.

PXE boot wait time

Use this item to set wait time to press [ESC] key to abort the PXE boot.

Media Detect Count

Use this item to set number of times presence of media will be checked.

► **CSM parameters**

Press [Enter] to make settings for the following sub-items:

Option ROM execution

Network

This option controls the execution of UEFI and Legacy PXE OpROM.
The optional settings are: [Do not launch]; [UEFI]; [Legacy].

Storage

This option controls the execution of UEFI and Legacy Storage OpROM.
The optional settings are: [Do not launch]; [UEFI]; [Legacy].

Other PCI devices

This item is for PCI devices other than Network, Mass storage or video defines which OpROM to launch.

The optional settings are: [Do not launch]; [UEFI]; [Legacy].

▶ **NVMe Configuration**

Press [Enter] to check NVMe controller and driver information.

▶ **USB Configuration**

Press [Enter] to make settings for the following sub-items:

USB Configuration

Legacy USB Support

The optional settings are: [Enabled]; [Disabled]; [Auto].

[Enabled]: To enable legacy USB support.

[Disabled]: to keep USB devices available only for EFI specification,

[Auto]: To disable legacy support if no USB devices are connected.

XHCI Hand-off

This is a workaround for OSES without XHCI hand-off support. The XHCI ownership change should be claimed by XHCI driver.

The optional settings are: [Enabled]; [Disabled].

USB Mass Storage Driver Support

The optional settings are: [Disabled]; [Enabled].

USB hardware delay and time-out

USB Transfer time-out

Use this item to set the time-out value for control, bulk, and interrupt transfers.

The optional settings are: [1 sec]; [5 sec]; [10 sec]; [20 sec].

Device reset time-out

Use this item to set USB mass storage device start unit command time-out.

The optional settings are: [10 sec]; [20 sec]; [30 sec]; [40 sec].

Device power-up delay

Use this item to set maximum time the device will take before it properly reports itself to the host controller. 'Auto' uses default value: for a root port it is 100 ms, for a hub port the delay is taken from hub descriptor. The optional settings: [Auto]; [Manual]. Select [Manual] you can set value for the following sub-item: **Device Power-up delay in seconds**, the delay range in from 1 to 40 seconds, in one second increments.

▶ **Intel(R) I211 Gigabit Network Connection- XX:XX:XX:XX:XX:XX/ Intel(R) Ethernet Connection (H) I211-LM- XX:XX:XX:XX:XX:XX**

This item shows current network brief information.

3-8 Chipset Menu

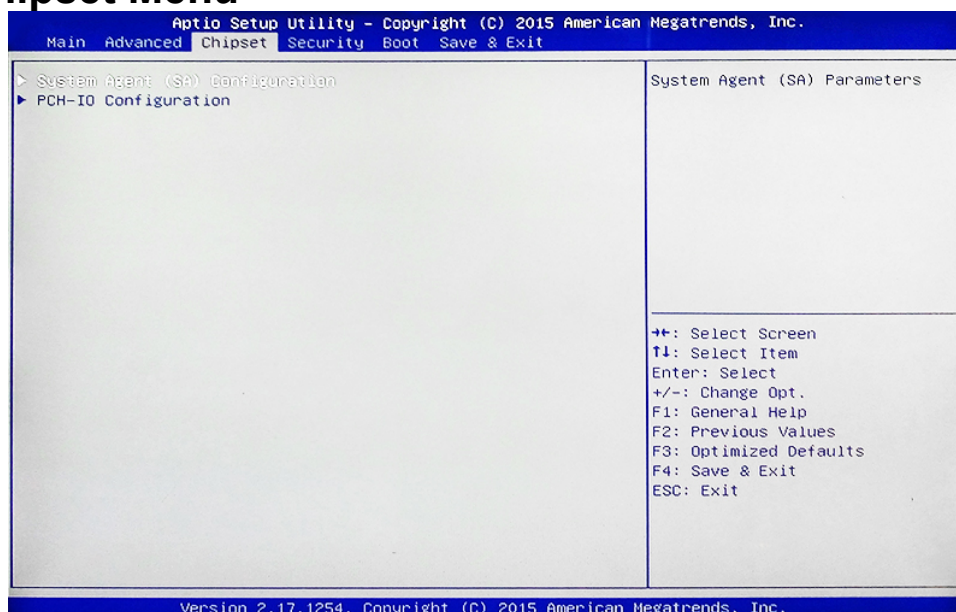

► **System Agent (SA) Configuration**

Press [Enter] to make settings for the following sub-items:

VT-d

The optional settings are: [Enabled]; [Disabled]. This item might not be available depending on configuration.

► **Graphics Configuration**

Press [Enter] to make further settings for Graphics Configuration.

Graphics Configuration

Primary Display

Use this item to select which of graphics device should be primary display.

The optional settings are: [Auto]; [IGFX]; [PEG].

Internal Graphics

The optional settings are: [Auto]; [Disabled]; [Enabled].

GTT Size

The optional settings are: [2MB]; [4MB]; [8MB].

Aperture Size

The optional settings are: [128MB]; [256MB]; [512MB]; [1024MB].

DVMT Pre-Allocated

Use this item to select DVMT 5.0 pre-allocated (fixed) graphics memory size used by the internal graphics device.

The optional settings are: [32M]; [64M]; [96M]; [128M]; [160M]; [192M]; [224M]; [256M]; [288M]; [320M]; [352M]; [384M]; [416M]; [448M]; [480M]; [512M]; [1024M]; [1536M]; [2048M]; [4M]; [8M]; [12M]; [16M]; [20M]; [24M]; [28M]; [32M/F7];

[36M]; [40M]; [44M]; [48M]; [52M]; [56M]; [60M].

DVMT Total Gfx Mem

Use this item to select DVMT 5.0 total graphics memory size used by the internal graphics device.

The optional settings are: [128M]; [256M]; [MAX].

Primary IGFX Boot Display

Use this item to select the video device which will be activated during POST. This has no effect if external graphics present. Secondary boot display selection will appear based on your selection. VGA modes will be supported only on primary display.

The optional settings are: [VBIOS Default]; [HDMI]; [DP]; [DVI].

**When set as [HDMI], [DP] or [DVI], the following sub-item shall appear:*

Secondary IGFX Boot Display

The optional settings are: [Disabled]; ; [HDMI]; [DP]; [DVI].

▶ **PEG Port Configuration**

Press [Enter] to make settings for the following sub-items:

PEG Port Configuration

PEG(PCIE1 Slot)

This will show current device connected to PCIE1 slot.

Max Link Speed

The optional settings are: [Auto]; [Gen1]; [Gen2]; [Gen3].

PEG(PCIE3 Slot)

This will show current device connected to PCIE3 slot.

Max Link Speed

The optional settings are: [Auto]; [Gen1]; [Gen2]; [Gen3].

▶ **Memory Configuration**

Press [Enter] to view brief information for the working memory module.

▶ **PCH-IO Configuration**

Press [Enter] to make settings for the following sub-items:

USB Controller

The optional settings are: [Disabled]; [Enabled].

HD Audio

The optional settings are: [Disabled]; [Enabled]; [Auto].

Onboard Lan1 Controller

Use this item to enable or disable onboard NIC

Wake on LAN

Use this item to enable or disable integrated LAN to wake the system. The

Wake on LAN can not be disabled if ME is on at Sx state.

Onboard LAN2 Controller

Use this item to enable or disable device or controller.

PCIE2 Slot/ PCIE4 Slot/ PCIE5 Slot/ MPE Slot

Use this item to enable or disable the PCI Express root port.

The optional settings are: [Disabled]; [Enabled].

Speed

The optional settings are: [Auto]; [Gen1]; [Gen2]; [Gen3].

System State after Power Failure

Use this item to specify what state to go to when power re-applied after a power failure(G3 state).

The optional settings are: [Always Off]; [Always On]; [Former State].

3-9 Security Menu

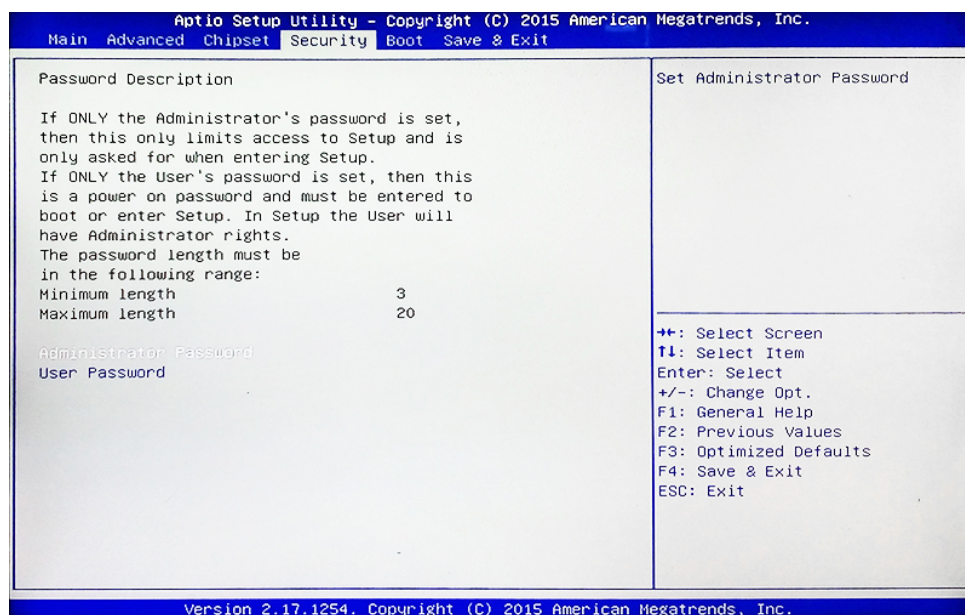

Security menu allow users to change administrator password and user password settings.

3-10 Boot Menu

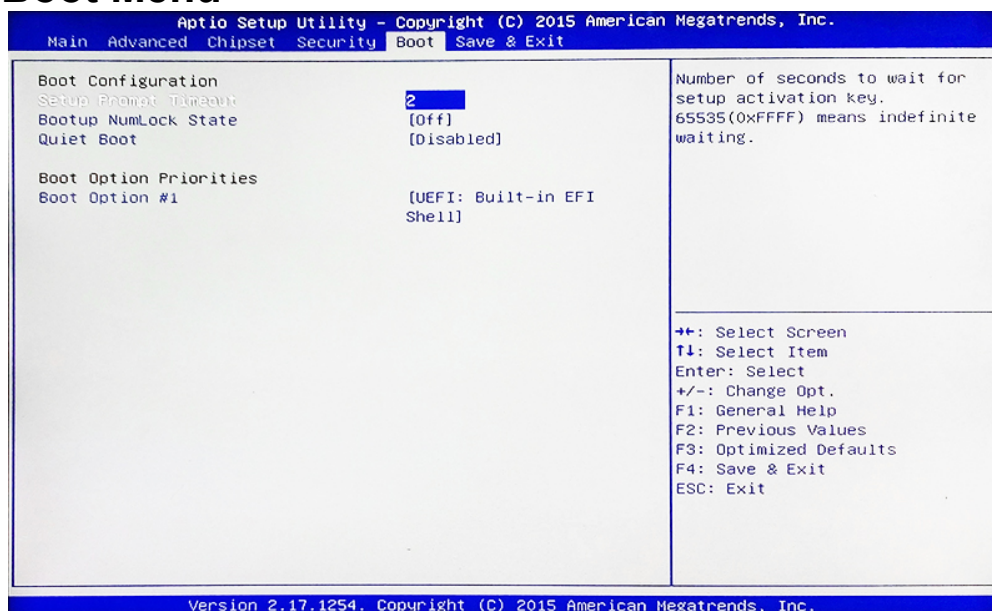

Boot Configuration

Setup Prompt Timeout

Use this item to set number of seconds to wait for setup activation key.

Bootup Numlock State

Use this item to select keyboard numlock state. The optional settings are: [On]; [Off].

Quiet Boot

The optional settings are: [Disabled]; [Enabled].

Boot Option Priorities

Boot Option #1/ Boot Option #2...

Use this item to decide system boot order from available options.

3-11 Save & Exit Menu

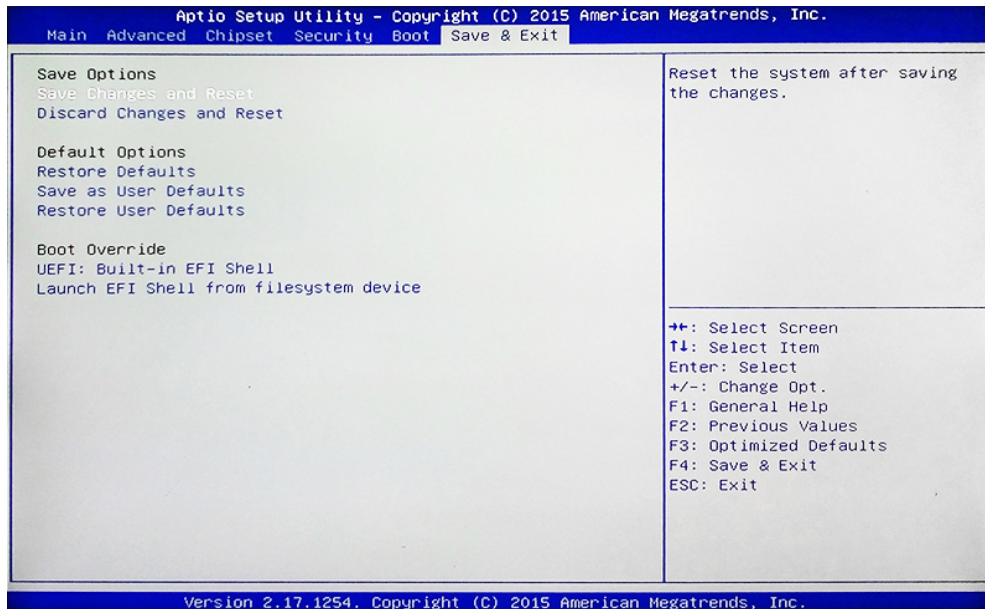

Save Changes and Reset

This item allows user to reset the system after saving the changes.

Discard Changes and Reset

This item allows user to reset the system without saving any changes.

Restore Defaults

Use this item to restore /load default values for all the setup options.

Save as User Defaults

Use this item to save the changes done so far as user defaults.

Restore User Defaults

Use this item to restore defaults to all the setup options.

Boot Override

UEFI:xx/...

Press this item to select the device as boot disk after save configuration and reset