

Technical Manual
Of
Intel Braswell Series CPU
Based IPC M/B

NO. G03-NF531R-F

Revision: 2.0

Release date: December 8, 2022

Trademark:

- * Specifications and Information contained in this documentation are furnished for information use only, and are subject to change at any time without notice, and should not be construed as a commitment by manufacturer.

Environmental Protection Announcement

Do not dispose this electronic device into the trash while discarding. To minimize pollution and ensure environment protection of mother earth, please recycle.



TABLE OF CONTENT

| | |
|--|----|
| ENVIRONMENTAL SAFETY INSTRUCTION | iv |
| USER'S NOTICE | v |
| MANUAL REVISION INFORMATION | v |
| ITEM CHECKLIST | v |
| CHAPTER 1 INTRODUCTION OF THE MOTHERBOARD | |
| 1-1 FEATURE OF MOTHERBOARD | 1 |
| 1-2 SPECIFICATION | 2 |
| 1-3 LAYOUT DIAGRAM | 3 |
| CHAPTER 2 HARDWARE INSTALLATION | |
| 2-1 JUMPER SETTING..... | 9 |
| 2-2 CONNECTORS AND HEADERS | 14 |
| 2-2-1 CONNECTORS | 14 |
| 2-2-2 HEADERS | 17 |
| CHAPTER 3 INTRODUCING BIOS | |
| 3-1 ENTERING SETUP..... | 24 |
| 3-2 BIOS MENU SCREEN..... | 25 |
| 3-3 FUNCTION KEYS..... | 26 |
| 3-4 GETTING HELP..... | 26 |
| 3-5 MEMU BARS..... | 27 |
| 3-6 MAIN MENU | 27 |
| 3-7 ADVANCED MENU | 28 |
| 3-8 CHIPSET MENU | 42 |
| 3-9 SECURITY MENU | 46 |
| 3-10 BOOT MENU | 47 |
| 3-11 SAVE & EXIT MENU | 48 |



Environmental Safety Instruction

- Avoid the dusty, humidity and temperature extremes. Do not place the product in any area where it may become wet.
- 0 to 40 centigrade is the suitable temperature. (The figure comes from the request of the main chipset)
- Generally speaking, dramatic changes in temperature may lead to contact malfunction and crackles due to constant thermal expansion and contraction from the 'welding spots' that connect components and PCB. Computer should go through an adaptive phase before it boots when it is moved from a cold environment to a warmer one to avoid condensation phenomenon. These water drops attached on PCB or the surface of the components can bring about phenomena as minor as computer instability resulted from corrosion and oxidation from components and PCB or as major as short circuit that can burn the components. Suggest starting the computer until the temperature goes up.
- The increasing temperature of the capacitor may decrease the life of computer. Using the close case may decrease the life of other device because the higher temperature in the inner of the case.
- Attention to the heat sink when you over-clocking. The higher temperature may decrease the life of the device and burned the capacitor.

USER'S NOTICE

COPYRIGHT OF THIS MANUAL BELONGS TO THE MANUFACTURER. NO PART OF THIS MANUAL, INCLUDING THE PRODUCTS AND SOFTWARE DESCRIBED IN IT MAY BE REPRODUCED, TRANSMITTED OR TRANSLATED INTO ANY LANGUAGE IN ANY FORM OR BY ANY MEANS WITHOUT WRITTEN PERMISSION OF THE MANUFACTURER.

THIS MANUAL CONTAINS ALL INFORMATION REQUIRED TO USE THIS MOTHER-BOARD SERIES AND WE DO ASSURE THIS MANUAL MEETS USER'S REQUIREMENT BUT WILL CHANGE, CORRECT ANY TIME WITHOUT NOTICE. MANUFACTURER PROVIDES THIS MANUAL "AS IS" WITHOUT WARRANTY OF ANY KIND, AND WILL NOT BE LIABLE FOR ANY INDIRECT, SPECIAL, INCIDENTAL OR CONSEQUENTIAL DAMAGES (INCLUDING DAMAGES FOR LOSS OF PROFIT, LOSS OF BUSINESS, LOSS OF USE OF DATA, INTERRUPTION OF BUSINESS AND THE LIKE).

PRODUCTS AND CORPORATE NAMES APPEARING IN THIS MANUAL MAY OR MAY NOT BE REGISTERED TRADEMARKS OR COPYRIGHTS OF THEIR RESPECTIVE COMPANIES, AND THEY ARE USED ONLY FOR IDENTIFICATION OR EXPLANATION AND TO THE OWNER'S BENEFIT, WITHOUT INTENT TO INFRINGE.

Manual Revision Information

| Reversion | Revision History | Date |
|-----------|------------------|------------------|
| 2.0 | Second Edition | December 8, 2022 |

Item Checklist

- Motherboard
- Cable(s)

Chapter 1

Introduction of the Motherboard

1-1 Feature of Motherboard

- Onboard Intel® Braswell series SoC Processor, with low power consumption never denies high performance
- Support 1* DDR3L 1600MHz SO-DIMM, maximum capacity up to 8GB
- Support HDMI, Display Port, LVDS/eDP(cobo Triple Independent Displays)
- Support 1 * SATAIII (6Gb/s) device
- Onboard 1* half-size Mini-PCIE slot
- Onboard 1* M.2 slot (M-key, type-2242 SATA interface for SSD device)
- Support 2 * RJ-45 LAN port
- Support 1*external RJ-45 COM port & 5 * internal COM port (COM 2 support RS232/422/485)
- Support 4* USB 3.0 port
- Support CPU Smart FAN
- Wide range DC source, 9~36V Lockable DC-in jack
- Compliance with ErP standard
- Support Watchdog function

1-2 Specification

| Spec | Description |
|-----------------------|---|
| Design | <ul style="list-style-type: none"> ● 3.5" SBC Form Factor; PCB size: 148mm * 102mm |
| Embedded CPU | <ul style="list-style-type: none"> ● Intel® Braswell SoC CPU* ● *CPU model varies from different IPC options. Please consult your dealer for more information of onboard CPU. |
| Memory | <ul style="list-style-type: none"> ● 1 * DDR3L SO-DIMM slot ● Support 1* DDR3L 1600 MHz SO-DIMM up to 8GB |
| Expansion Slot | <ul style="list-style-type: none"> ● 1* Half-size Mini-PCIE slot (MPE) |
| Storage | <ul style="list-style-type: none"> ● 1*SATAIII 6G/s port ● 1* M.2 Slot (Socket 3, M-key, support type-2242 SSD) |
| LAN Chip | <ul style="list-style-type: none"> ● Integrated with 2* Realtek RTL8119I PCI-E Gigabit LAN chips ● Support Fast Ethernet LAN function of providing 10/100/1000Mbps Ethernet data transfer rate |
| Audio Chip | <ul style="list-style-type: none"> ● Realtek ALC662-VD 6-Ch HD Audio Codec integrated ● Audio driver and utility included |
| BIOS | <ul style="list-style-type: none"> ● AMI 64MB Flash ROM |
| Rear I/O | <ul style="list-style-type: none"> ● 1* 9V~36V lockable DC-in power jack ● 1* Display port ● 1* HDMI port ● 4* USB 3.0 port ● 2* RJ-45 LAN port ● 1* RJ-45 COM port for Console (RJ45_COM1) |
| Internal I/O | <ul style="list-style-type: none"> ● 1* SATA Power-out connector ● 1* CPUFAN connector ● 1* Front panel header ● 1* LAN LED activity header ● 1* GPIO_CON header ● 1* 9-pin USB 2.0 header (Expansibile to 2* USB 2.0 ports) ● 1* Front panel audio header |

| | |
|--|--|
| | <ul style="list-style-type: none"> ● 1* RS232/422/485 serial port header (COM2) ● 4* RS232 serial port header (COM3/4/5/6) ● 1* case open header ● 1* 24-bit dual channel LVDS header or 2 Lane eDP (one of them) ● 1* LVDS/EDP inverter ● 1* Buzzer |
|--|--|

*** Note:** Many PCs now include XHCI USB controllers which allow for the support of USB 3.0 and higher USB speeds. This inclusion of XHCI controllers has lessened the need for EHCI USB controllers within platforms. However, legacy operating systems (OS) may not natively recognize XHCI controllers. You might need to pre-install XHCI driver while desiring to install a non-xHCI OS (ex.Windows* 7) on Intel platforms which do not include EHCI controllers. Please contact your representative for more details.

1-3 Layout Diagram

Rear IO Panel Diagram:

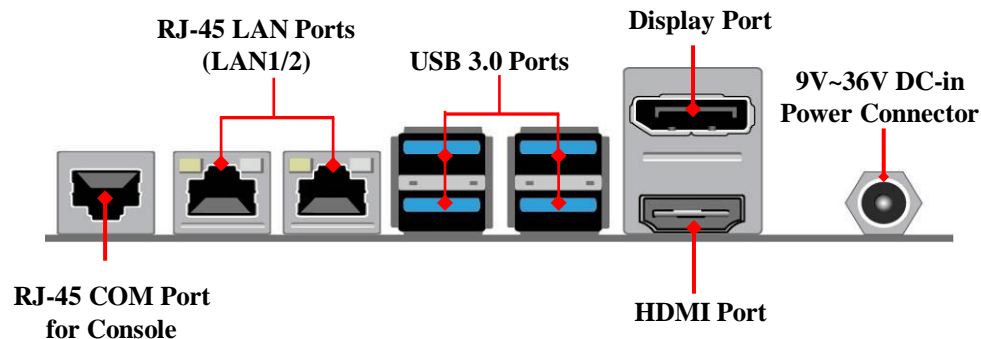

Motherboard Internal Diagram-Front Side

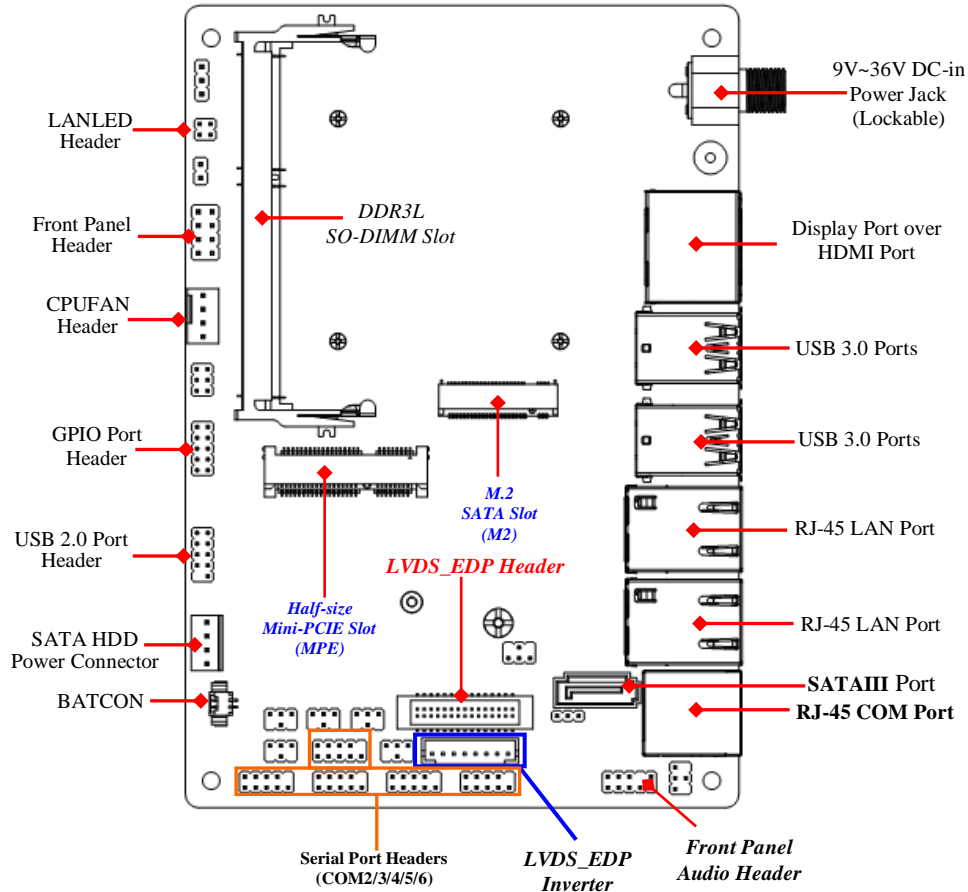

Motherboard Internal Diagram-Back Side

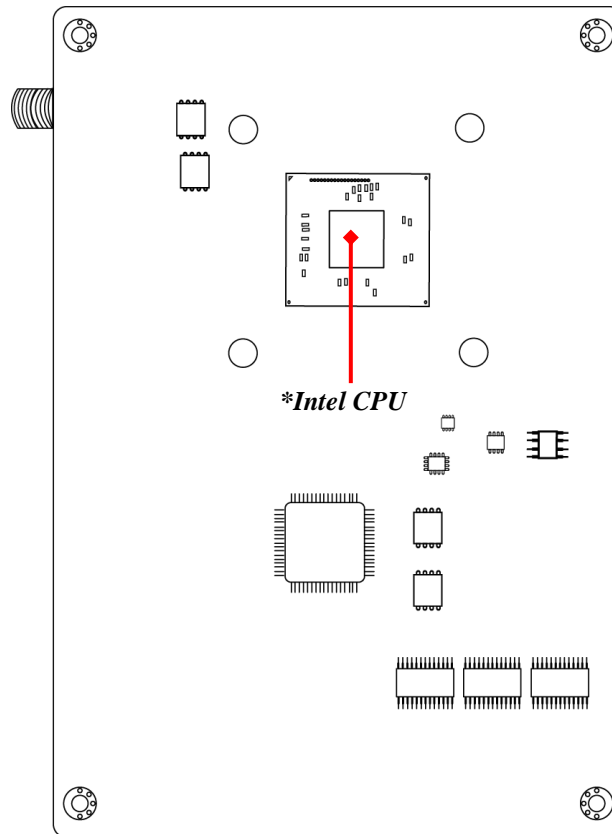

***Note:** CPU is the most important part of the board and very fragile to any possible harm. Make sure that there is no damage to the CPU during any installation procedures!

Jumper Positions:

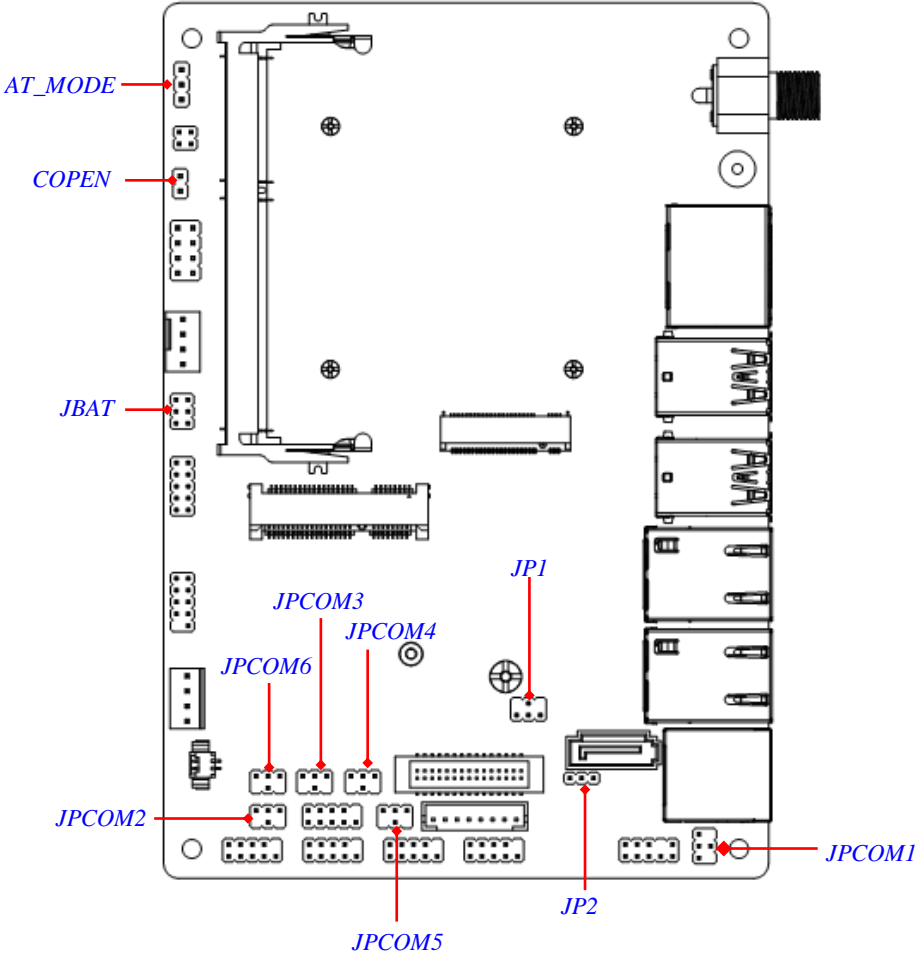

Jumper

| Jumper | Name | Description |
|---------|--|--------------|
| JBAT | Pin 1-2: Clear CMOS Pin 3-4: RTC Reset Pin 5-6: Flash Override | 6- Pin Block |
| AT_MODE | ATX Mode/AT Mode Select | 3-Pin Block |
| COPEN | Case Open Message Display Select | 2-Pin Block |
| JP1 | LVDS2 VCC 3.3V/5V/12V Select | 4-Pin Block |
| JP2 | INVERTER2 Backlight 5V/12V Select | 3-Pin Block |
| JPCOM1 | RJ45_COM1 Port Pin Function Select | 4-pin Block |
| JPCOM2 | COM2 Header Pin9 Function Select | 4-Pin Block |
| JPCOM3 | COM3 Header Pin9 Function Select | 4-Pin Block |
| JPCOM4 | COM4 Header Pin9 Function Select | 4-Pin Block |
| JPCOM5 | COM5 Header Pin9 Function Select | 4-Pin Block |
| JPCOM6 | COM6 Header Pin9 Function Select | 4-Pin Block |

Connectors

| Connector | Name |
|-----------|--|
| DCIN | 9V~36V DC-in System Power Jack |
| DP_HDMI | Top: Display Port Connector Bottom: HDMI Port Connector |
| USB2/USB1 | USB 3.0 Port Connector x 4 |
| LAN2/LAN1 | RJ-45 LAN Port Connector x2 |
| RJ45_COM1 | RJ-45 COM Port Connector for Console |
| SATA1 | SATAIII Connector |
| SATAPW | SATA Power out Connector |
| CPUFAN | CPUFAN Connector |
| MPE1 | Half-size Mini-PCIE Slot |
| M2 | M.2 Socket 3 Slot |

Headers

| Header | Name | Description |
|------------|--|--------------|
| FP | Front Panel Header(PWR LED/ HDD LED/Power Button /Reset) | 8-pin Block |
| LAN_LED | LAN Activity LED Header | 4-pin Block |
| GPIO_CON | GPIO Header | 10-pin Block |
| FP_USB1 | USB 2.0 Header | 9-pin Block |
| COM2 | RS232/422/485 Serial Port Header | 9-pin Block |
| COM3/4/5/6 | RS232 Serial Port Header | 9-pin Block |
| FP_AUDIO | Front Panel Audio Header | 9-pin Block |
| LVDS_EDP | LVDS/EDP Combo Header | 30-pin Block |
| INVERTER1 | LVDS/EDP Inverter Header | 8-pin Block |

Chapter 2

Hardware Installation

2-1 Jumper Setting

Pin 1&2 of JBAT (6-pin): Clear CMOS RAM Setting

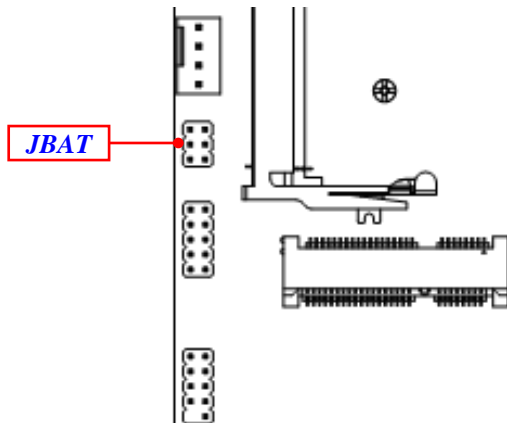

*Pin 1&2 of JBAT →
Clear CMOS Settings*

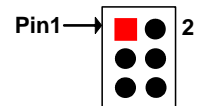

1-2 Open: Normal;

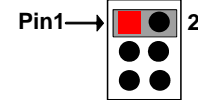

1-2 Closed: Clear CMOS.

Pin 3&4 of JBAT (6-pin): RTC RESET Select

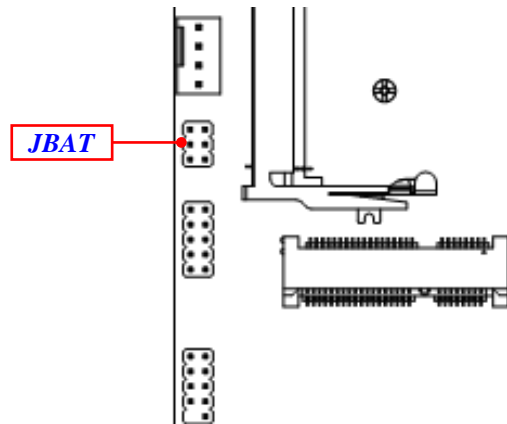

Pin 3&4 of JBAT → RTC RESET

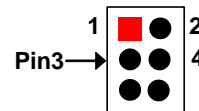

3-4 Open: Open: Normal;

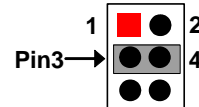

3-4 Closed: RTC RESET.

Pin 5&6 of JBAT (6-pin): Flash Override Select

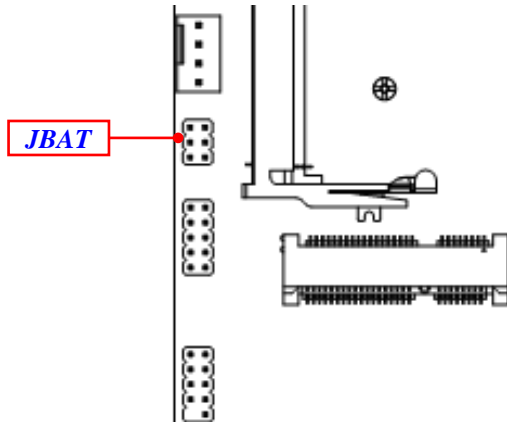

Pin 5&6 of JBAT → Flash Override

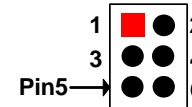

5-6 Open: Enable Security Measures in the Flash Descriptor(Default);

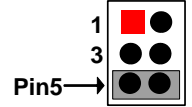

5-6 Closed: Disable Security Measures in the Flash Descriptor(Override).

AT_MODE (3-pin): AT Mode /ATX Mode Select

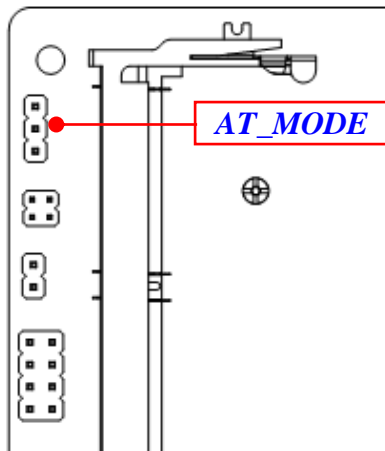

AT_MODE → ATX/AT Mode Select

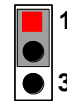

1-2 Closed: ATX Mode Selected;

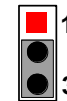

2-3 Closed: AT Mode Selected.

***ATX Mode Selected:** Press power button to power on after power input ready;
AT Mode Selected: Directly power on as power input ready.

COPEN (2-pin): Case Open Message Display Function Select

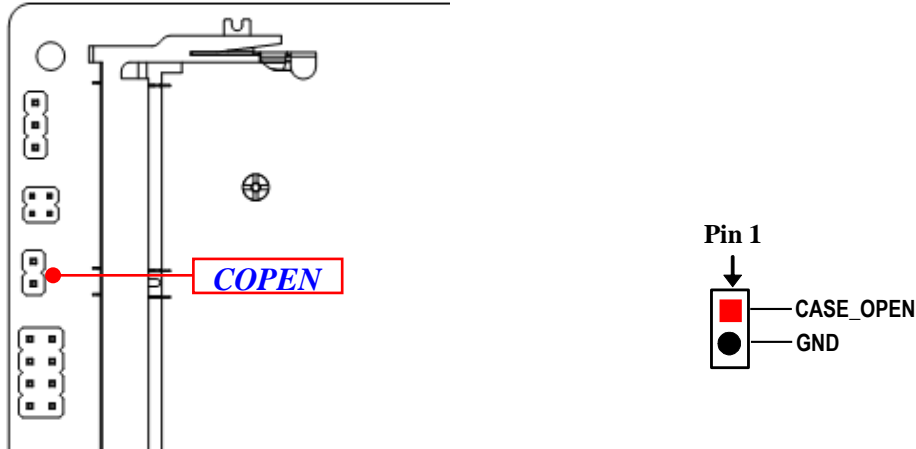

Pin 1-2 Short: When Case open function pin short to GND, the Case open function was detected. When Used, needs to enter BIOS and enable 'Case Open Detect' function. In this case if your case is removed, next time when you restart your computer, a message will be displayed on screen to inform you of this.

JP1 (4-pin): LVDS2 VCC 3.3V/5V/12V Select

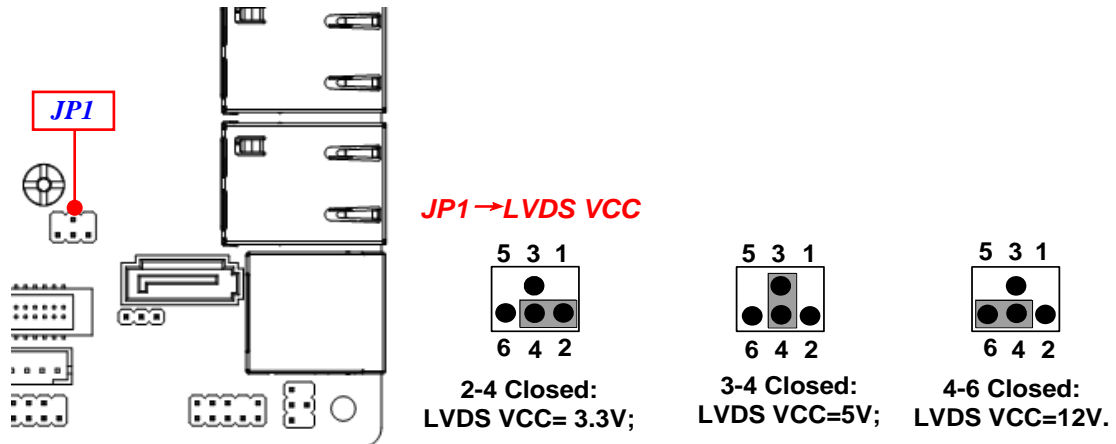

JP2 (3-pin): INVERTER2 Backlight 5V/12V Select

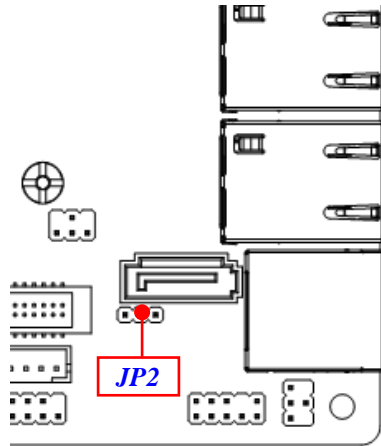

JP2→INVERTER Backlight

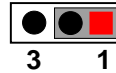

1-2 Closed: Inverter Backlight= 5V;

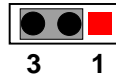

2-3 Closed: Inverter Backlight= 12V.

JPCOM1 (4-pin): RJ45_COM1 Port Pin-5 VCC Select

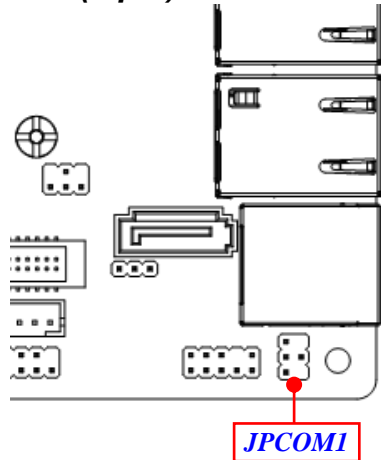

JPCOM1→RJ45_COM1 Pin-5 VCC

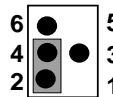

2-4 Closed:
Pin5=NC
(Default);

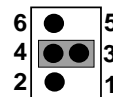

3-4 Closed:
Pin5=+5V;

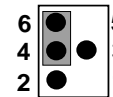

4-6 Closed:
Pin5=+12V.

JPCOM2/3/4/5/6 (4-pin): COM Header Pin9 Function Select

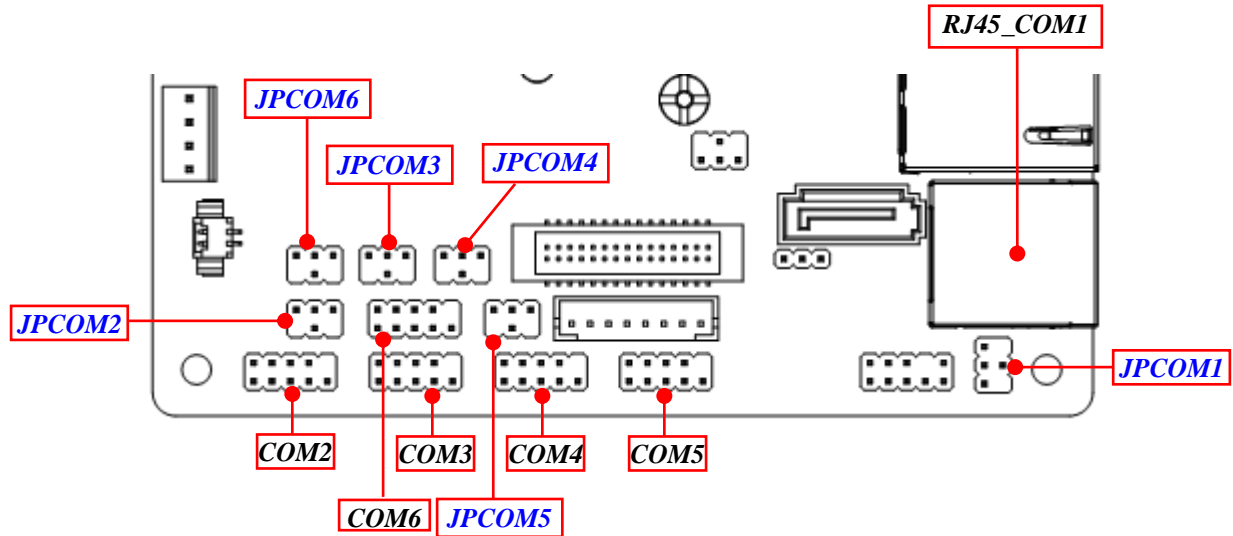

- JPCOM2→COM2 Pin-9 VCC**
- JPCOM3→COM3 Pin-9 VCC**
- JPCOM4→COM4 Pin-9 VCC**
- JPCOM5→COM5 Pin-9 VCC**
- JPCOM6→COM6 Pin-9 VCC**

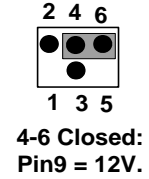
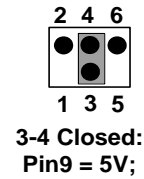
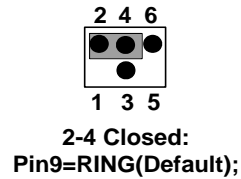





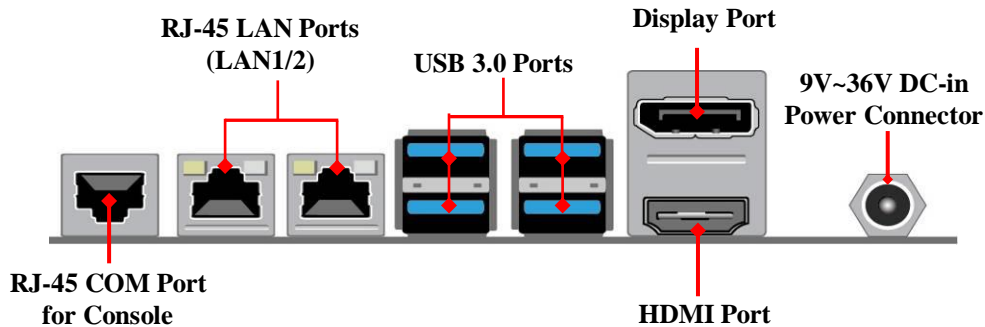

2-2 Connectors and Headers

2-2-1 Connectors

(1) Rear I/O Connectors



| <i>Icon</i> | <i>Name</i> | <i>Function</i> |
|---|--------------------------------|---|
|  | 9V~36V DC-in Power Jack | For user to connect compatible power adapter to provide power supply for the system. |
|  | Display Port | To the system to corresponding display device with compatible DP cable. |
|  | HDMI Port | To connect display device that support HDMI specification. |
|  | USB 3.0 Port | To connect USB keyboard, mouse or other devices compatible with USB specification. USB 3.0 ports supports up to 5Gbps data transfer rate. |
|  | RJ-45 LAN Port | This connector is standard RJ-45 LAN jack for Network connection. |
|  | RJ-45 COM Port | This connector is a RJ-45 COM port for console function. |

(2) RJ45_COM1(8-pin block): RJ-45 COM Port Connector for Console

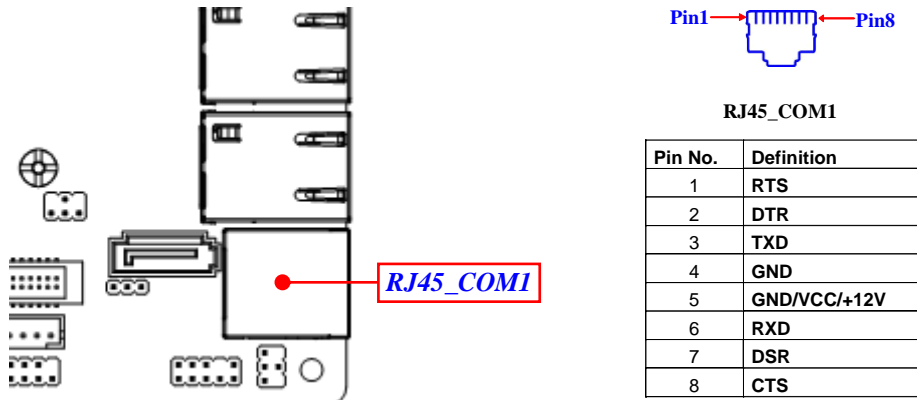

Note: Please set **Pin (2-4)** of Jumper **JPCOM1** as closed, when apply Console cable to RJ45-COM1 port (refer to page-12).

(3) SATA1 (7-pin): SATAIII Port connector

SATA1 port is a high-speed SATAIII port that supports 6GB/s transfer rate.

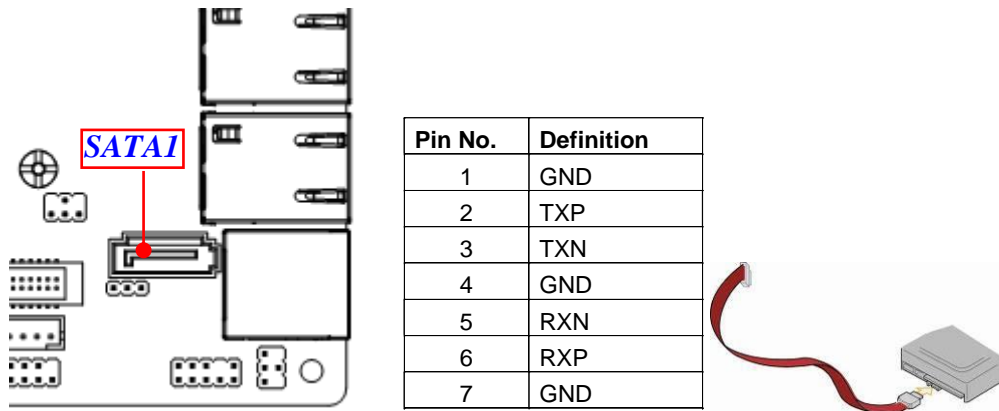

(4) SATAPW (4-pin): SATA Power Out Connector

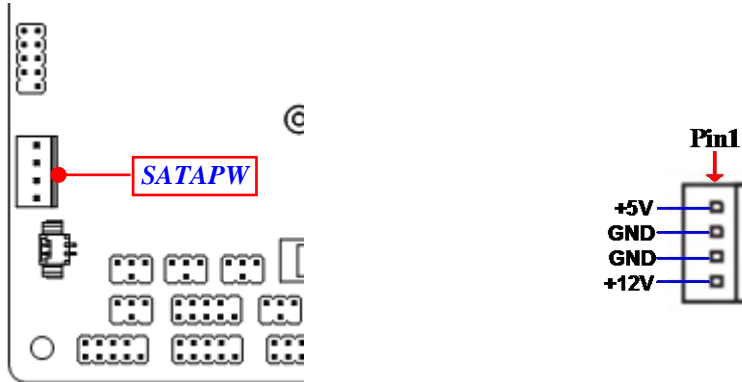

Warning: Make sure that Pin-1 of compatible SATA Power connector is inserted into corresponding Pin-1 of SATAPW to avoid possible damage to the board and hard disk driver!

(5) CPUFAN (4-pin): CPUFAN Connector

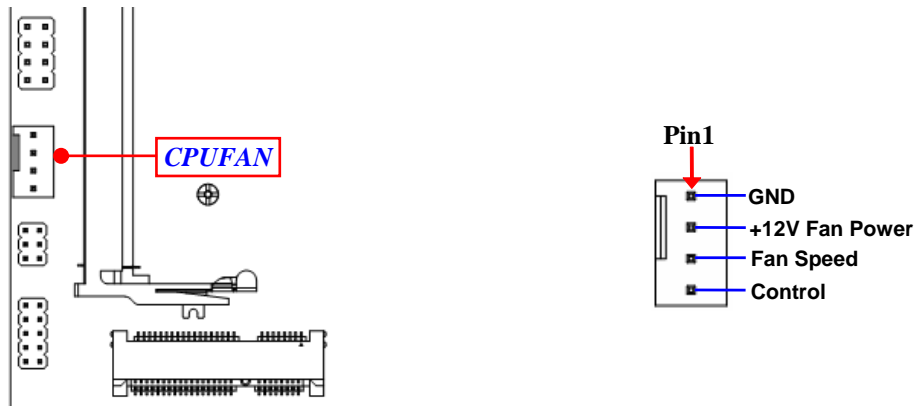

(6) BATCON (2-pin): Battery Connector

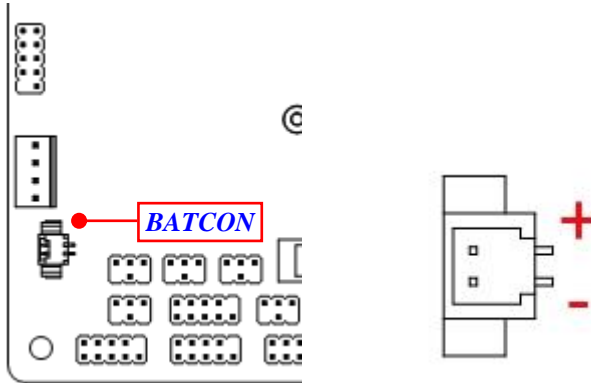

2-2-2 Headers

(1) FP (8-pin): Front Panel Header

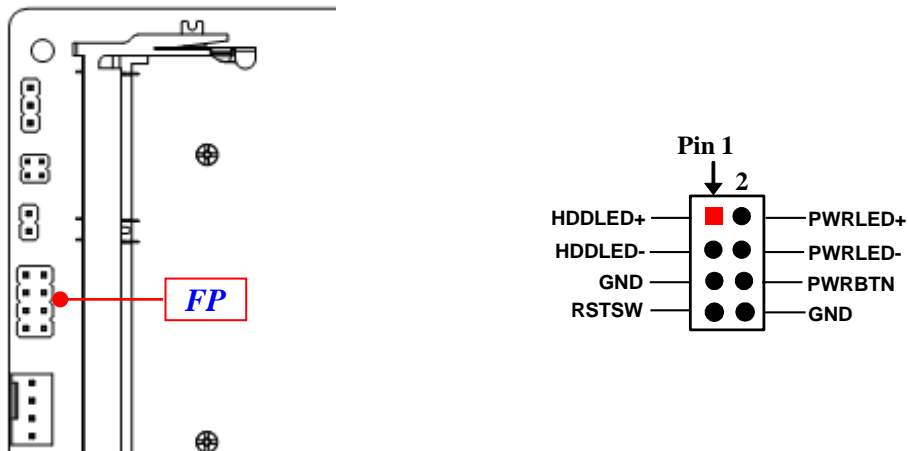

(2) LAN_LED (4-pin): LAN Activity LED Header

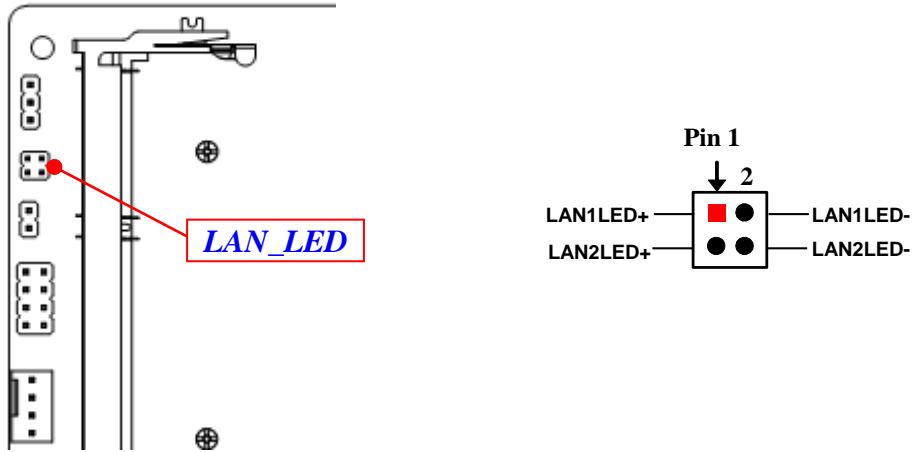

(3) GPIO_CON (10-pin): GPIO Header

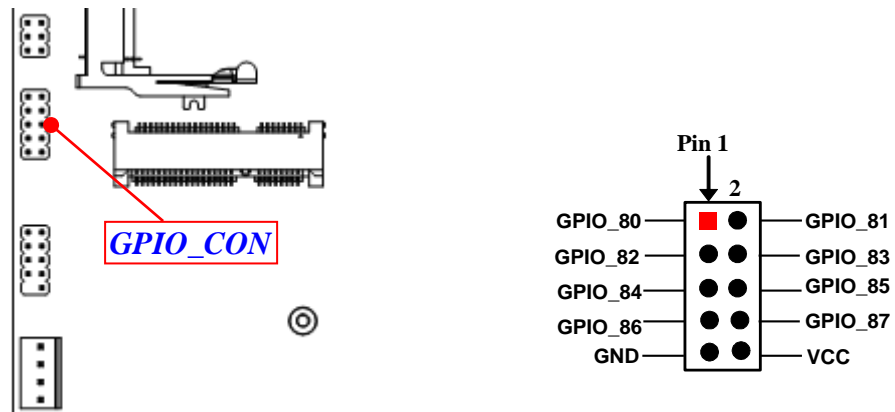

(4) FP_USB1 (9-pin): USB 2.0 Port Header

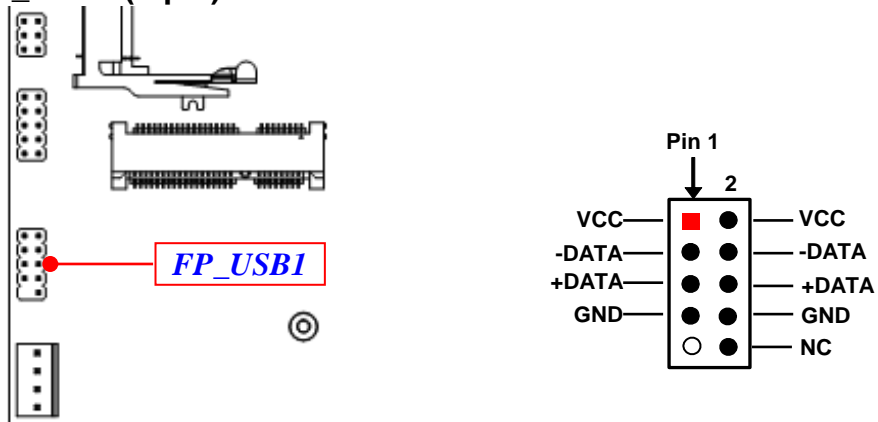

(5) COM2/3/4/5/6 (9-pin): Serial Port Header

COM2 (9-pin): RS232/422/485 Serial Port Header

COM3/4/5/6 (9-pin): RS232 Serial Port Header

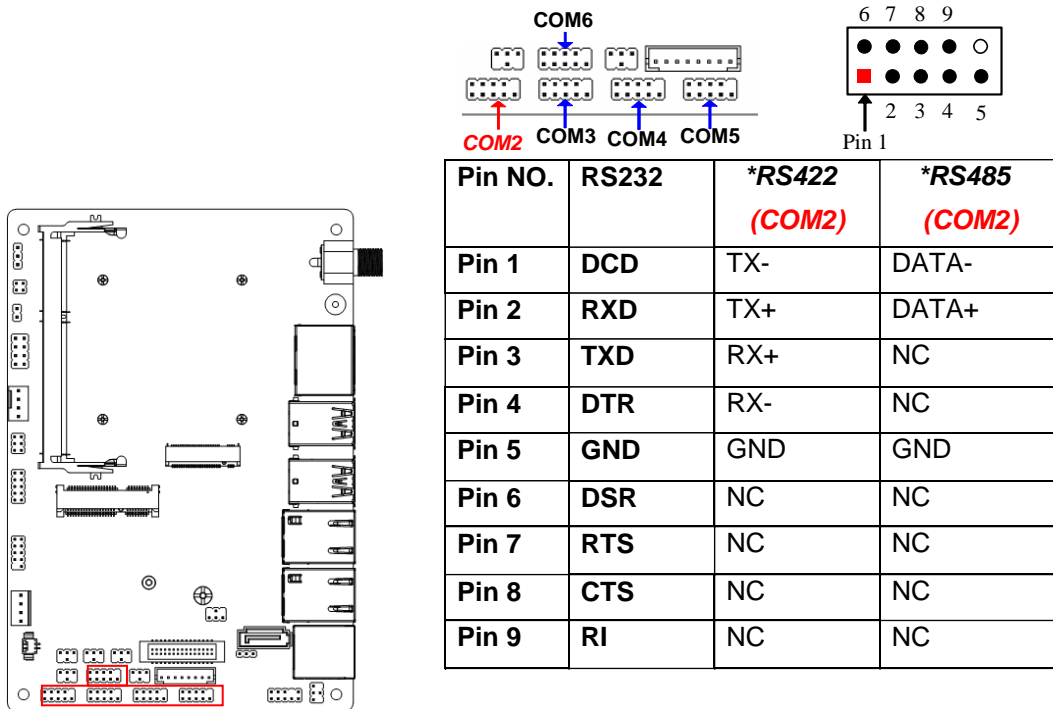

***Notice:** COM2 header can function as RS232/422/485 port. In normal settings COM1 functions as RS232 port. With compatible COM cable COM2 can function as RS422 or RS 485 port. User also needs to go to BIOS to set '**Transmission Mode Select**' for COM2 as [RS422] or [RS485] for boards that support RS422/485 function before connecting compatible COM cable to COM2 header.

(6) FP_AUDIO (9-pin): Line-Out, MIC-In Header

This header connects to Front Panel Line-out, MIC-In connector with cable.

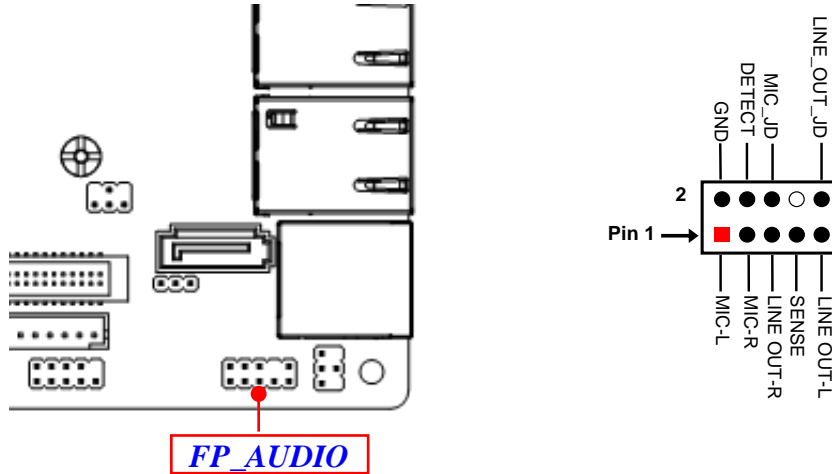

(7) INVERTER1 (8-pin): LVDS/EDP Inverter Header

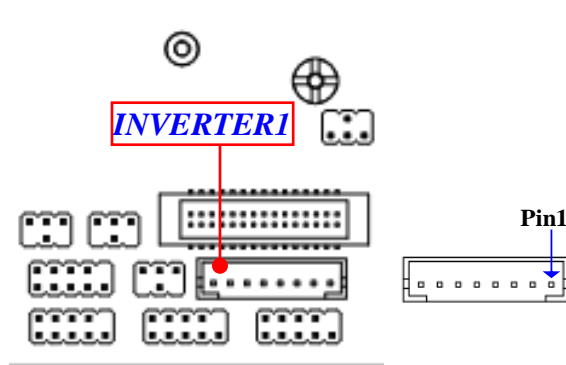

| Pin No. | Definition |
|---------|-------------------|
| 1 | Backlight Enable |
| 2 | Backlight PWM |
| 3 | VLED |
| 4 | VLED |
| 5 | GND |
| 6 | GND |
| 7 | Backlight Up SW |
| 8 | Backlight Down SW |

Warning! Find Pin-1 location of the inverter and make sure that the installation direction is correct! Otherwise serious harm will occur to the board/display panel!!

(8) LVDS_EDP (30-pin): 24-bit Dual Channel LVDS / 2 Lane EDP Header

8.1 LVDS Function:

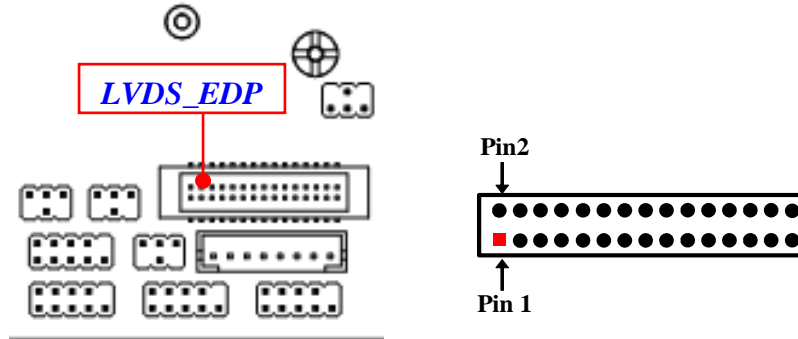

| Pin NO. | Pin Define | Pin NO. | Pin Define |
|---------|--------------|---------|--------------|
| Pin 1 | LVDSB_DATAN3 | Pin 2 | LVDSB_DATAP3 |
| Pin 3 | LVDS_CLKBN | Pin 4 | LVDS_CLKBP |
| Pin 5 | LVDSB_DATAN2 | Pin 6 | LVDSB_DATAP2 |
| Pin 7 | LVDSB_DATAN1 | Pin 8 | LVDSB_DATAP1 |
| Pin 9 | LVDSB_DATAN0 | Pin 10 | LVDSB_DATAP0 |
| Pin 11 | NC/DDC_DATA | Pin 12 | NC/DDC_CLK |
| Pin 13 | GND | Pin 14 | GND |
| Pin 15 | GND | Pin 16 | GND |
| Pin 17 | LVDSA_DATAP3 | Pin 18 | LVDSA_DATAN3 |
| Pin 19 | LVDS_CLKAP | Pin 20 | LVDS_CLKAN |
| Pin 21 | LVDSA_DATAP2 | Pin 22 | LVDSA_DATAN2 |
| Pin 23 | LVDSA_DATAP1 | Pin 24 | LVDSA_DATAN1 |
| Pin 25 | LVDSA_DATAP0 | Pin 26 | LVDSA_DATAN0 |
| Pin 27 | VLCD | Pin 28 | VLCD |
| Pin 29 | VLCD | Pin 30 | VLCD |

8.2 EDP Function:

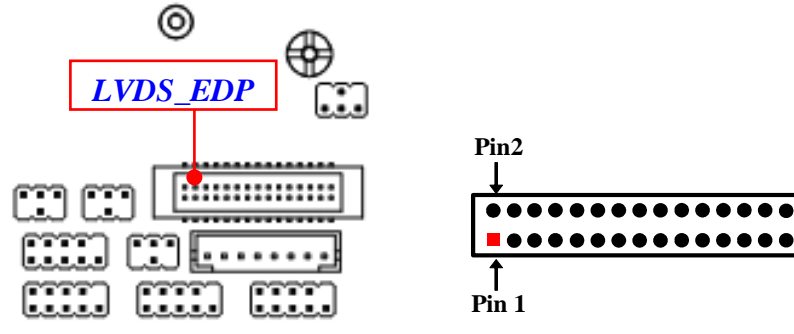

| Pin NO. | Pin Define | Pin NO. | Pin Define |
|---------|------------|---------|------------|
| Pin 1 | NC | Pin 2 | NC |
| Pin 3 | NC | Pin 4 | NC |
| Pin 5 | NC | Pin 6 | NC |
| Pin 7 | NC | Pin 8 | NC |
| Pin 9 | NC | Pin 10 | NC |
| Pin 11 | NC | Pin 12 | NC |
| Pin 13 | GND | Pin 14 | GND |
| Pin 15 | GND | Pin 16 | GND |
| Pin 17 | NC | Pin 18 | NC |
| Pin 19 | eDP_AUXP | Pin 20 | eDP_AUXN |
| Pin 21 | eDP_TX0P | Pin 22 | eDP_TX0N |
| Pin 23 | eDP_TX1P | Pin 24 | eDP_TX1N |
| Pin 25 | NC | Pin 26 | NC |
| Pin 27 | VLCD | Pin 28 | VLCD |
| Pin 29 | VLCD | Pin 30 | VLCD |

***Note:** LVDS_EDP functions as LVDS and EDP Combo header. User also needs to go to BIOS to set 'LCD Panel Type' (refer to Page-43) to before connecting compatible cable to the header.

Chapter 3

Introducing BIOS

Notice! The BIOS options in this manual are for reference only. Different configurations may lead to difference in BIOS screen and BIOS screens in manuals are usually the first BIOS version when the board is released and may be different from your purchased motherboard. Users are welcome to download the latest BIOS version form our official website.

The BIOS is a program located on a Flash Memory on the motherboard. This program is a bridge between motherboard and operating system. When you start the computer, the BIOS program will gain control. The BIOS first operates an auto-diagnostic test called POST (power on self test) for all the necessary hardware, it detects the entire hardware device and configures the parameters of the hardware synchronization. Only when these tasks are completed done it gives up control of the computer to operating system (OS). Since the BIOS is the only channel for hardware and software to communicate, it is the key factor for system stability, and in ensuring that your system performance as its best.

3-1 Entering Setup

Power on the computer and by pressing immediately allows you to enter Setup. If the message disappears before your respond and you still wish to enter Setup, restart the system to try again by turning it OFF then ON or pressing the “RESET” button on the system case. You may also restart by simultaneously pressing <Ctrl>, <Alt> and <Delete> keys. If you do not press the keys at the correct time and the system does not boot, an error message will be displayed and you will again be asked to

```

Please select boot device:
-----
UEFI: Built-in EFI Shell
Enter Setup
-----
↑ and ↓ to move selection
ENTER to select boot device
ESC to boot using defaults

```

Press to enter Setup; press <F7> to enter pop-up Boot menu.

3-2 BIOS Menu Screen

The following diagram show a general BIOS menu screen:

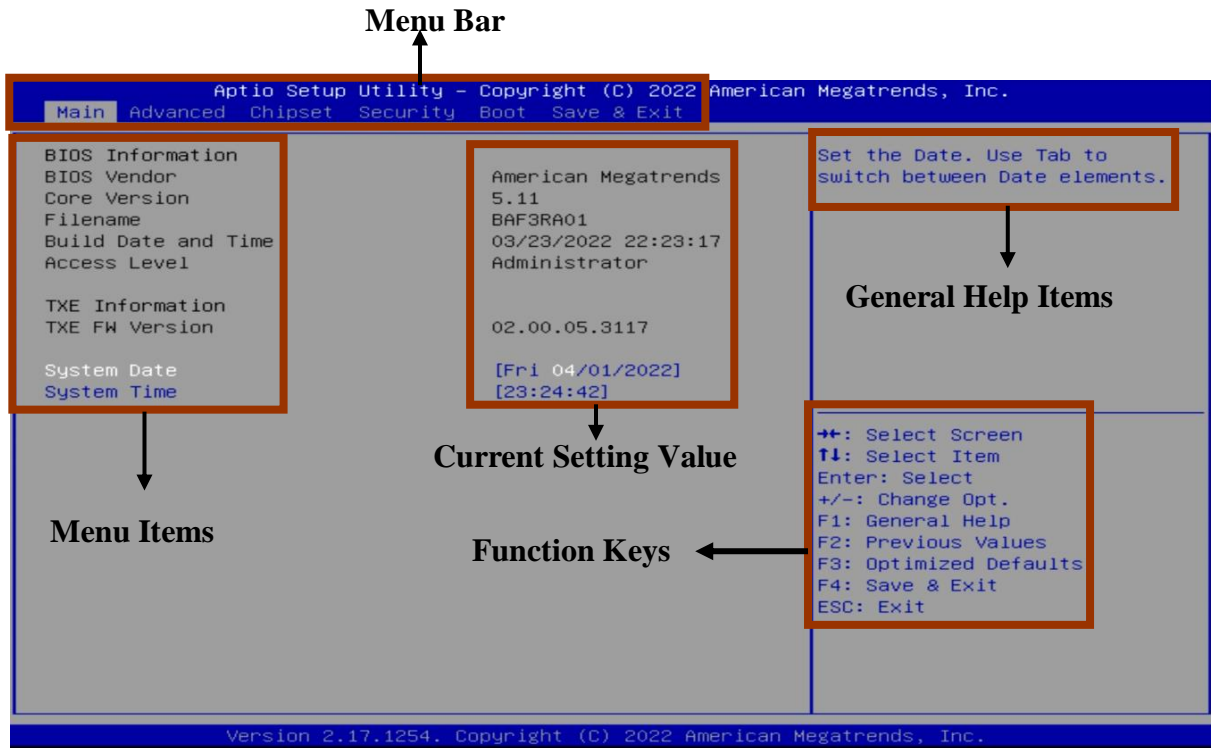

3-3 Function Keys

In the above BIOS Setup main menu of, you can see several options. We will explain these options step by step in the following pages of this chapter, but let us first see a short description of the function keys you may use here:

- Press ←→ (left, right) to select screen;
- Press ↑↓ (up, down) to choose, in the main menu, the option you want to confirm or to modify.
- Press <Enter> to select.
- Press <+>/<-> keys when you want to modify the BIOS parameters for the active option.
- [F1]: General help.
- [F2]: Previous value.
- [F3]: Optimized defaults.
- [F4]: Save & Exit.
- [F7]: To enter pop-up boot menu to select boot device.
- Press <Esc> to quit the BIOS Setup.

3-4 Getting Help

Main Menu

The on-line description of the highlighted setup function is displayed at the top right corner the screen.

Status Page Setup Menu/Option Page Setup Menu

Press [F1] to pop up a small help window that describes the appropriate keys to use and the possible selections for the highlighted item. To exit the Help Window, press <Esc>.

3-5 Menu Bars

There are six menu bars on top of BIOS screen:

| | |
|------------------------|---|
| Main | To change system basic configuration |
| Advanced | To change system advanced configuration |
| Chipset | To change chipset configuration |
| Security | Password settings |
| Boot | To change boot settings |
| Save & Exit | Save setting, loading and exit options. |

User can press the right or left arrow key on the keyboard to switch from menu bar. The selected one is highlighted.

3-6 Main Menu

Main menu screen includes some basic system information. Highlight the item and then use the <+> or <-> and numerical keyboard keys to select the value you want in each item.

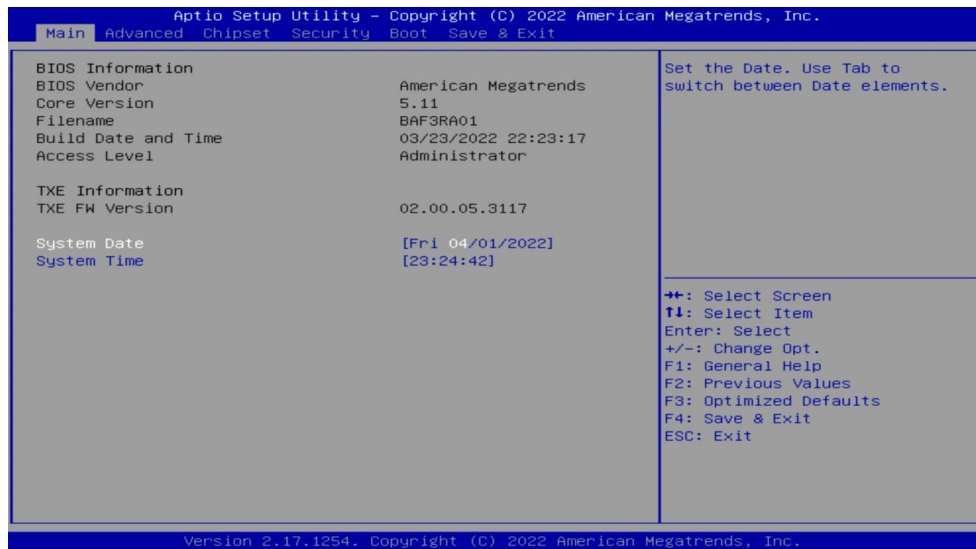

System Date

Set the date. Please use [Tab] to switch between date elements.

System Time

Set the time. Please use [Tab] to switch between time elements.

3-7 Advanced Menu

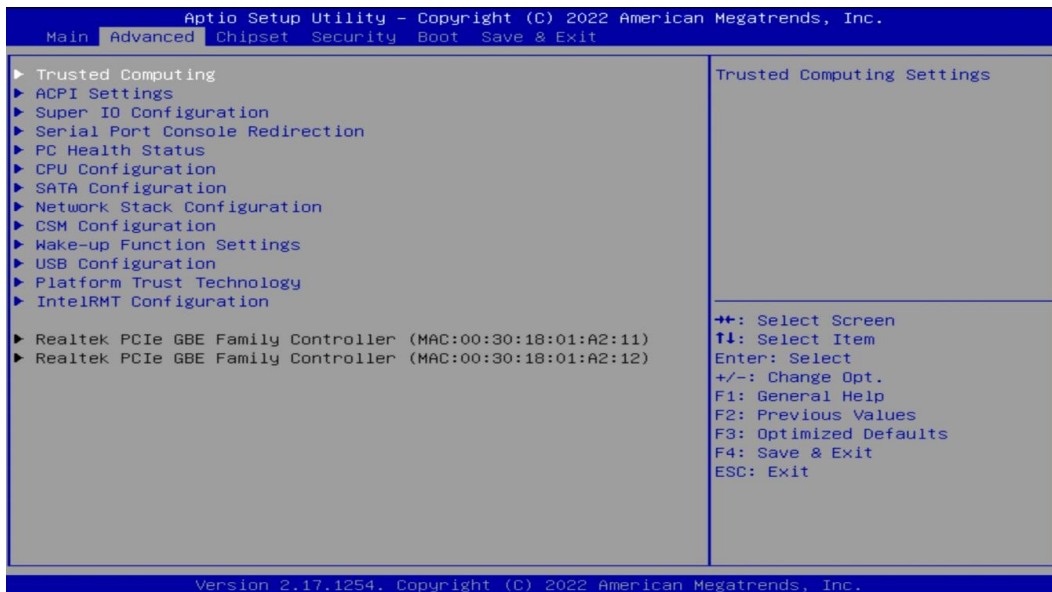

▶ Trusted Computing

Press [Enter] to enable or disable Security Device Support.

TPM20 Device Found

Security Device Support

Use this item to enable or disable BIOS support for security device. 0.S will not show Security device. TCG EFI protocol and INT1A interface will not be available. The optional settings: [Disabled]; [Enabled].

Press [Enter] to make settings for the following sub-items:

Active PCR Banks

Available PCR Banks

SHA-1 PCR Bank

Use this item to enable or disable SHA-1 PCR Bank

The optional settings: [Disabled]; [Enabled].

SHA256 PCR Bank

Use this item to enable or disable SHA256 PCR Bank

The optional settings: [Disabled]; [Enabled].

Pending Operation

Use this item to Schedule an Operation for the security device.

**Note: Your computer will reboot during restart in order to change state of security device.*

The optional settings: [None]; [TPM Clear].

TPM2.0 UEFI Spec Version

Use this item to select the TCG2 spec. version supported.

The optional settings: [1.0]; [1.x].

[1.0]: compatible mode for Win8/Win10.

[1.x]: for TCG2 newer spec. compatible mode for Win10.

▶ **ACPI Settings**

Press [Enter] to make settings for the following sub-item:

ACPI Settings

ACPI Sleep State

Use this item to select the highest ACPI sleep state the system will enter when the suspend button is pressed.

The optional settings are: [Suspend Disabled]; [S3 (Suspend to RAM)].

▶ **Super I/O Configuration**

Press [Enter] to make settings for the following sub-items:

Super IO Configuration

▶ **Serial Port 1 Configuration**

Press [Enter] to make settings for the following items:

Serial Port

Use this item to enable or disable serial port (COM).

The optional settings: [Disabled]; [Enabled].

Press [Enter] to make settings for the following items:

Device Settings

Change Settings

Use this item to select an optimal setting for super IO device.

The optional settings are: [Auto]; [IO= 3F8h; IRQ=4]; [IO= 2F8h; IRQ=3]; [IO= 3E8h; IRQ=4]; [IO= 2E8h; IRQ=3].

Serial Port FIFO Mode

The optional settings are: [16-Byte FIFO]; [32-Byte FIFO]; [64-Byte FIFO]; [128-Byte FIFO].

▶ **Serial Port 2 Configuration**

Press [Enter] to make settings for the following items:

Serial Port

Use this item to enable or disable serial port (COM).

The optional settings: [Disabled]; [Enabled].

Press [Enter] to make settings for the following items:

Device Settings

Change Settings

Use this item to select an optimal setting for super IO device.

The optional settings are: [Auto]; [IO= 3F8h; IRQ=4]; [IO= 2F8h; IRQ=3]; [IO= 3E8h; IRQ=4]; [IO= 2E8h; IRQ=3].

Transmission Mode Select

The optional settings are: [RS422]; [RS232]; [RS485].

Mode Speed Select

The optional settings are: [RS232/RS422/RS485=250kbps]; [RS232=1Mbps, RS422/RS485=10Mbps].

Serial Port FIFO Mode

The optional settings are: [16-Byte FIFO]; [32-Byte FIFO]; [64-Byte FIFO];

[128-Byte FIFO].

▶ **Serial Port 3 Configuration / Serial Port 4 Configuration**

Press [Enter] to make settings for the following items:

Serial Port

Use this item to enable or disable serial port (COM).

The optional settings: [Disabled]; [Enabled].

Press [Enter] to make settings for the following items:

Device Settings

Change Settings

Use this item to select an optimal setting for super IO device.

The optional settings are: [Auto]; [IO= 3F8h; IRQ=10]; [IO= 2F8h; IRQ=10]; [IO= 3E8h; IRQ=10]; [IO= 2E8h; IRQ=10]; [IO= 2F0h; IRQ=10]; [IO= 2E0h; IRQ=10]

Serial Port FIFO Mode

The optional settings are: [16-Byte FIFO]; [32-Byte FIFO]; [64-Byte FIFO]; [128-Byte FIFO].

▶ **Serial Port 5 Configuration / Serial Port 6 Configuration**

Press [Enter] to make settings for the following items:

Serial Port

Use this item to enable or disable serial port (COM).

The optional settings: [Disabled]; [Enabled].

Press [Enter] to make settings for the following items:

Change Settings

Use this item to select an optimal setting for super IO device.

The optional settings are: [Auto]; [IO= 3F8h; IRQ=11]; [IO= 2F8h; IRQ=11]; [IO= 3E8h; IRQ=11]; [IO= 2E8h; IRQ=11]; [IO= 2F0h; IRQ=11]; [IO= 2E0h; IRQ=11]

Serial Port FIFO Mode

The optional settings are: [16-Byte FIFO]; [32-Byte FIFO]; [64-Byte FIFO]; [128-Byte FIFO].

OS Select for Serial Port

Use this item to serial port support for Windows or Linux
The optional settings: [Windows]; [LINUX].

ERP Support

Use this item to Energy-Related Products function.

The optional settings: [Disabled]; [Enabled].

This item should be set as **[Disabled]** if you wish to have all active wake-up functions.

Case Open Detect

Use this item to detect if case have ever been opened. Show message in POST.

The optional settings: [Disabled]; [Enabled].

When set as [Enabled], system will detect if COPEN has been short or not (refer to [Page-11](#)); if Pin 1&2 of COPEN are short, system will show Case Open Message during POST.

WatchDog Reset Timer

Use this item to enable or disable WatchDog Timer reset function. When set as [Enabled], the following sub-items shall appear:

WatchDog Reset Timer Value

User can set a value in the range of [10] to [255].

WatchDog Reset Timer Unit

The optional settings are: [Sec.]; [Min.].

WatchDog Wake-up Timer

This item support WDT wake-up while ERP function is set as [Enabled].

The optional settings: [Disabled]; [Enabled].

When set as [Enabled], the following sub-items shall appear:

WatchDog Wake-up Timer Value

The setting range is [10] ~ [4095] seconds, or [1] ~ [4095] minutes.

WatchDog Wake-up Timer Unit

The optional settings are: [Sec.]; [Min.].

ATX Power Emulate AT Power

This item support Emulate AT power function, MB power On/Off control by power supply. Use needs to select 'AT or ATX Mode' on MB jumper at first (refer to AT_MODE jumper setting Pin 1&2 of for ATX Mode & Pin 2&3 of AT Mode Select).

▶ **Serial Port Console Redirection**

Press [Enter] to make settings for the following sub-items:

COM1

Console Redirection

Use this item to console redirection enable or disable.

The optional settings are: [Disabled]; [Enabled].

When set as [Enabled], user can make further settings in the 'Console Redirection Settings' screen:

▶ **Console Redirection Settings**

The settings specify how the host computer and the remote computer (which the user is using) will exchange data. Both computers should have the same or compatible settings.

Press [Enter] to make settings for the following sub-items.

COM1

Console Redirection Settings

Terminal Type

The optional settings are: [VT100]; [VT100+]; [VT-UTF8]; [ANSI].

[ANSI]: Extended ASCII char set.

[VT100]: ASCII char set

[VT100+]: Extends VT100 to support color, function keys, etc

[VT-UTF8]: Uses UTF8 encoding to map Unicode chars onto 1 or more bytes

Bits per second

Use this item to selects serial port transmission speed. The speed must be matched on the other side. Long or noisy lines may require lower speeds.

The optional settings are: [9600]; [19200]; [38400]; [57600]; [115200].

Data Bits

The optional settings are: [7]; [8].

Parity

A parity bit can be sent with the data bits to detect some transmission errors.

The optional settings are: [None]; [Even]; [Odd];[Mark]; [Space].

[Even]: Parity bit is 0 if the num of 1 in the data bits is even

[Odd]: Parity bit is 0 if num of 1 in the data bits is odd

[Mark]: parity bit is always 1

[Space]: Parity bit is always 0. Allow for error detection

Stop Bits

Use this item to stop bits indicate the end of a serial data packet.(A start bit indicates the beginning). The standard setting is 1 stop bit. Communication with slow devices may require more than 1 stop bit.

The optional settings are: [1]; [2].

Flow Control

Use this item to flow control can prevent data loss from buffer overflow.

When sending data, if the receiving buffers are full, a 'stop' signal can be sent to stop the data flow. Once the buffers are empty, a 'start' signal can be sent to re-start the flow. Hardware flow control uses two wires to send start/stop signals.

The optional settings are: [None]; [Hardware RTS/CTS].

VT-UTF8 Combo Key Support

Use this item to enable VT-UTF8 combination key support for ANSI/VT100 terminals.

The optional settings are: [Disabled]; [Enabled].

Recorder Mode

Use this item to with this mode enabled only text will be sent. This is to capture Terminal data.

The optional settings are: [Disabled]; [Enabled].

Resolution 100x31

Use this item to enables or disables extended terminal resolution.

The optional settings are: [Disabled]; [Enabled].

Legacy OS Redirection Resolution

Use this item to on Legacy OS, the number of rows and columns supported redirection.

The optional settings are: [80x24]; [80x25].

Putty Keypad

Use this item to select functionkey and KeyPad on Putty.

The optional settings are: [VT100]; [LINUX]; [XTERMR6]; [SCO]; [ESCN]; [VT400].

Redirection After BIOS POST

Use this item to the settings specify if BootLoader is selected then Legacy console redirection is disabled before booting to Legacy OS, Default value is always enable which means Legaacy console Redirection is enabled for Legacy OS.

The optional settings are: [Always Enable]; [BootLoader].

Serial Port for Out-of-Band Management/ Windows Emergency Management Services (EMS)

Console Redirection

The optional settings: [Disabled]; [Enabled].

When set as [Enabled], user can make further settings in ‘Console Redirection Settings’:

▶ **Console Redirection Settings**

The settings specify how the host computer and the remote computer (which the user is using) will exchange data. Both computers should have the same or compatible settings.

Press [Enter] to make settings for the following sub-items.

Out-of-Band Mgmt Port

The default setting is: [COM1].

Terminal Type

Use this item to VT-UTF8 is the preferred terminal type for out-of-band

management. The next best choice is VT100+ and then VT100. See above, in Console Redirection Settings page, for more Help with Terminal Type/Emulation.

The optional settings are: [VT100]; [VT100+]; [VT-UTF8]; [ANSI].

Bits per second

Use this item to Selects serial port transmission speed. The speed must be matched on the other sside. Long or noisy lines may require lower speeds.

The optional settings are: [9600]; [19200]; [57600]; [115200].

Flow Control

Flow control can prevent data loss from buffer overflow When sending data, if the receiving buffers are full, a 'stop' signal can be sent to stop the data flow, Once the buffers are empty, a 'start' signal can be sent to re-start the flow. Hardware flow control uses two wires to send start/stop signals.

The optional settings are: [None]; [Hardware RTS/CTS]; [Software Xon/Xoff].

Data Bits

The default setting is: [8].

**This item may or may not show up, depending on different configuration.*

Parity

The default setting is: [None].

**This item may or may not show up, depending on different configuration.*

Stop Bits

The default setting is: [1].

**This item may or may not show up, depending on different configuration.*

▶ **PC Health Status**

Press [Enter] to view current hardware health status, set shutdown temperature, or make further settings in '**SmartFAN Configuration**'.

▶ **SmartFAN Configuration**

Press [Enter] to make settings for SmartFAN Configuration:

CPUFAN Smart Mode

The optional settings: [Disabled]; [Enabled].

When set as [Enabled], the following sub-items shall appear:

CPUFAN Full-Speed Temperature

Use this item to set CPUFAN full speed temperature. Fan will run at full speed when above the preset temperature.

CPUFAN Full-Speed Duty

Use this item to set CPUFAN full speed duty. Fan will run at full speed when above the pre-set duty.

CPUFAN Idle-Speed Temperature

Use this item to set CPUFAN idle speed temperature. Fan will run at idle speed when below the pre-set temperature.

CPUFAN Idle-Speed Duty

Use this item to set CPUFAN idle speed duty. Fan will run at idle speed when below the pre-set duty.

Shutdown Temperature

Use this item to select system shutdown temperature.

The optional settings are: [Disabled]; [65°C/148°F]; [70°C/156°F]; [75°C/164°F]; [80°C/172°F]; [85°C/180°F].

▶ **CPU Configuration**

Press [Enter] to view current CPU configuration and make settings for the following sub-items:

Limit CPUID Maximum

The optional settings: [Disabled]; [Enabled].

This item should be set as [Disabled] for Windows XP.

Intel Virtualization Technology

The optional settings: [Enabled]; [Disabled].

When set as [Enabled], a VMM can utilize the additional hardware capabilities provided by Vanderpool Technology.

EIST

The optional settings: [Disabled]; [Enabled].

Use this item to enable or disable Intel SpeedStep.

When set as [Enabled], the following item shall appear:

Turbo Mode

The optional settings: [Disabled]; [Enabled].

CPU C State Report

Use this item to enable or disable CPU C state report to OS.

The optional settings: [Disabled]; [Enabled].

When set as [Enabled], the following item shall appear:

Max CPU C State

This item controls Max C state that the processor will support.

The optional settings: [C7]; [C6]; [C1].

▶ **SATA Configuration**

Press [Enter] to make settings for the following sub-items:

SATA Configuration

SATA Controller

The optional settings are: [Enabled]; [Disabled].

When set as [Enabled], the following items shall appear:

SATA Mode Selection

The default setting is: [AHCI].

Use this item to determines how SATA controller operate.

SATA Interface Speed

Use this item to select SATA Interface Speed, CHV A1 always with Gen1 Speed.

The optional settings are: [Gen1]; [Gen2]; [Gen3].

SATA Port / M.2 SATA

Port

The optional settings are: [Enabled]; [Disabled].

▶ **Network Stack Configuration**

Press [Enter] to go to '**Network Stack**' screen to make further settings.

Network Stack

The optional settings are: [Enabled]; [Disabled].

Use this item to enable/disable UEFI Network stack.

When set as [Enabled], the following sub-items shall appear:

Ipv4 PXE Support

The optional settings are: [Disabled]; [Enabled].

Use this item to enable Ipv4 PXE Boot Support. When set as [Disabled], Ipv4 boot optional will not be created.

Ipv6 PXE Support

The optional settings are: [Disabled]; [Enabled].

Use this item to enable Ipv6 PXE Boot Support. When set as [Disabled], Ipv6 boot optional will not be created.

PXE boot wait time

Use this item to set wait time to press [ESC] key to abort the PXE boot.

Media Detect Count

Use this item to set number of times presence of media will be checked.

The optional settings range from [1] to [50].

▶ **CSM Configuration**

Use this item to enable/disable, option ROM execution settings, etc.

Press [Enter] to make settings for the following sub-items:

Compatibility Support Module Configuration

Boot Option Filter

This item controls Legacy/UEFI ROMs priority.

The optional settings are: [UEFI and Legacy]; [Legacy only]; [UEFI only].

Network

This item controls the execution of UEFI and legacy PXE OpROM.

The optional settings are: [Do not launch]; [UEFI]; [Legacy].

Storage

This item controls the execution of UEFI and Legacy Storage OpROM.

The optional settings are: [Do not launch]; [UEFI]; [Legacy].

Other PCI devices

This item determines OpROM execution policy for devices other than Network, storage or video.

The optional settings are: [Do not launch]; [UEFI]; [Legacy].

▶ **Wake-up Function Settings**

Press [Enter] to make settings for the following sub-items:

Wake-up System with Fixed Time

Use this item to enable or disable system wake-up by RTC alarm.

The optional settings: [Disabled]; [Enabled].

When set as [Enabled], system will wake on the hour/min/sec specified.

Wake-up Hour

Use this item to 0-23. For example, 3 for 3am and 15 for 3pm.

Wake-up Minute

Use this item to 0-59.

Wake-up Second

Use this item to 0-59.

Wake-up System with Dynamic Time

Use this item to enable or disable system wake-up by RTC alarm.

The optional settings: [Disabled]; [Enabled].

When set as [Enabled], system will wake on the current time + increased minute(s). The settings range is from [1] ~ [60] minute(s).

Wake-up Time Increase

Use this item to 1-60 minute(s)

USB Wake-up from S3-S4

Use this item to enable or disable USB Wake-up from S3-S4 state.

The optional settings: [Disabled]; [Enabled].

**This item is only supported when 'ERP Support' is set as [Disabled]. Please disable ERP before activating this function in S4 state.*

▶ **USB Configuration**

Press [Enter] to make settings for the following sub-items:

USB Configuration

Legacy USB Support

The optional settings are: [Enabled]; [Disabled]; [Auto].

[Enabled]: To enable legacy USB support.

[Disabled]: To keep USB devices available only for EFI specification,

[Auto]: To disable legacy support if no USB devices are connected.

XHCI Hand-off

This is a workaround for OSES without XHCI hand-off support. The XHCI ownership change should be claimed by XHCI driver.

The optional settings are: [Enabled]; [Disabled].

USB Mass Storage Driver Support

Use this item to enable or disable USB Mass storage driver support

The optional settings are: [Disabled]; [Enabled].

USB Hardware Delays and Time-outs:

USB Transfer Time-out

Use this item to set the time-out value for control, bulk, and interrupt transfers.

The optional settings are: [1 sec]; [5 sec]; [10 sec]; [20 sec].

Device Reset Time-out

Use this item to set USB mass storage device start unit command time-out.

The optional settings are: [10 sec]; [20 sec]; [30 sec]; [40 sec].

Device Power-up Delay

Use this item to set maximum time the device will take before it properly reports itself to the host controller.

The optional settings are: [Auto]; [Manual].

'Auto' uses default value: for a root port it is 100 ms, for a hub port the delay is taken from hub descriptor.

Select [Manual] you can set value for the following sub-item: '**Device Power-up Delay in Seconds**'.

Device Power-up Delay in Seconds

The delay range is from [1] to [40] seconds, in one second increments.

▶ **Platform Trust Technology**

Press [Enter] to make settings for the following sub-item:

TPM Configuration

fTPM

The optional settings are: [Enabled]; [Disabled].

▶ **IntelRMT Configuration**

Press [Enter] to make settings for the following sub-item:

IntelRMT Configuration

Intel RMT Support

The optional settings are: [Enabled]; [Disabled].

Intel RMT(Ready Mode Technology) SSDT table will be loaded if it is set as [Enabled].

When set as **[Enabled]**, user can make further settings in the following item:

HW Notification

This item is for user to select hardware notification enabling status.

The optional settings are: [Disabled]; [Enabled].

▶ Realtek PCIe GBE Family Controller (MAC:XX:XX:XX:XX:XX:XX)

▶ Realtek PCIe GBE Family Controller (MAC:XX:XX:XX:XX:XX:XX)

This item gives Intel gigabit ethernet controller basic driver information.

3-8 Chipset Menu

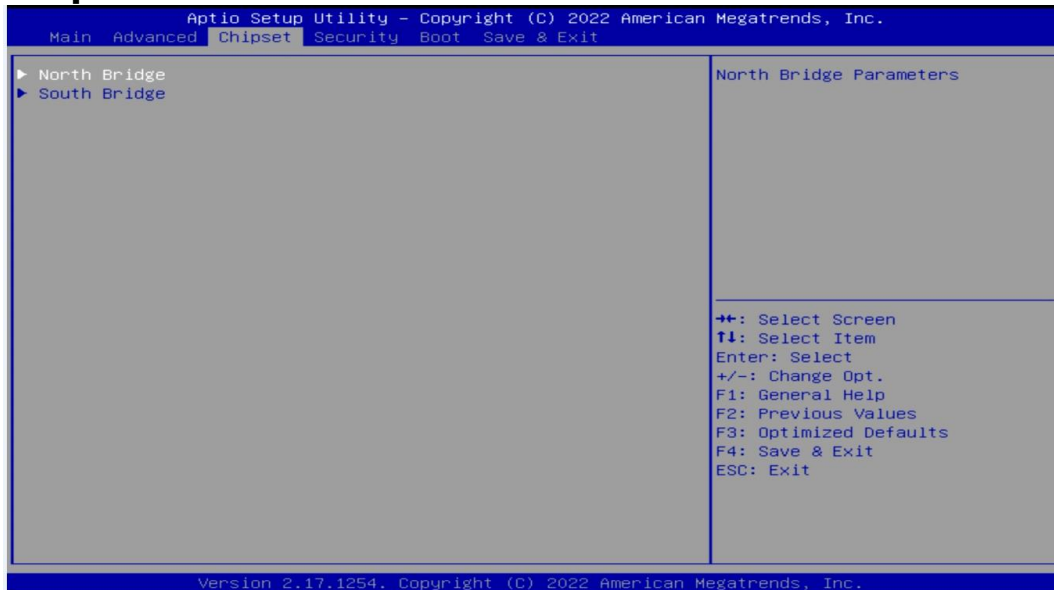

▶ North Bridge

Press [Enter] to view memory configurations or make settings for the following

sub-items:

PAVC

Use this item to enable or disable protected audio video control.

The optional settings are: [Disabled]; [Enabled].

DVMT Pre-Allocated

Use this item to select DVMT 5.0 pre-allocated (fixed) graphics memory size used by the internal graphics device.

The optional settings are: [32M]; [64M]; [96M]; [128M]; [160M]; [192M]; [224M]; [256M]; [288M]; [320M]; [352M]; [384M]; [416M]; [448M]; [480M]; [512M].

DVMT Total Gfx Mem

Use this item to select DVMT 5.0 total graphics memory size used by the internal graphics device.

The optional settings are: [128MB]; [256MB]; [MAX].

Aperture Size

Use this item to select the GTT size

The optional settings are: [128MB]; [256MB]; [512MB].

GTT Size

Use this item to select the Aperture size

The optional settings are: [2MB]; [4MB]; [8MB].

Primary IGFX Boot Display

Use this item to select the video device which will be activated during POST. This has no effect if external graphics present. Secondary boot display selection will appear based on your selection. VGA modes will be supported only on primary display.

The optional settings are: [Auto]; [Display Port]; [HDMI]

Secondary IGFX Boot Display

Use this item to select secondary display device

The optional settings are: [Disabled]; [Display Port]; [HDMI].

Active LFP

The optional settings are: [Disabled]; [Enabled].

** **Note:** When set as 'Enabled', user can make further settings in 'LCD Panel Type'; 'Backlight Control'*

LCD Panel Type

Use this item to manually select LCD panel used by internal graphics device by selecting the appropriate setup item.

The optional setting are: [800x 480 1ch 18-bit]; [800x 600 1ch 18-bit]; [800x 600 1ch 24-bit]; [1024 x 600 1ch 18-bit]; [1024 x 768 1ch 18-bit]; [1024 x 768 1ch 24-bit]; [1280 x 768 1ch 24-bit]; [1280 x 800 1ch 18-bit]; [1280 x 800 1ch 24-bit]; [1366 x 768 1ch 18-bit]; [1366 x 768 1ch 24-bit]; [1440 x 900 2ch 18-bit]; [1440 x 900 2ch 24-bit]; [1280 x 1024 2ch 24-bit]; [1680 x 1050 2ch 24-bit]; [1920 x 1080 2ch 24-bit]; [eDP].

Banklight Control

Use this item to Back light control setting

The optional settings are: [PWM Inverted]; [PWM Normal]

LVDS FW Protect

The optional settings are: [Enabled]; [Disabled].

Memory Information

Total Memory

Memory Sloto

Max TOLUD

Use this item to Maximum value of TOLUD.

he optional settings are: [2GB]; [2.25GB]; [2.5GB]; [2.75GB]; [3GB]

▶ **South Bridge**

Press [Enter] to further setting USB device configuration.

Mini PCIE

The default setting is: [Enabled].

Mini PCIE Speed

The optional settings are: [Auto]; [Gen 2]; [Gen 1].

Onboard PCIE LAN1

The optional settings are: [Enabled]; [Disabled].

Onboard PCIE LAN2

The optional settings are: [Enabled]; [Disabled].

Audio Controller

Use this item to control detection of the Azalia device.

The optional settings are: [Disabled]; [Enabled].

[Disabled]: Azalia will be unconditionally disabled;

[Enabled]: Azalia will be unconditionally enabled.

Azalia HDMI Codec

Use this item to enable or disable internal HDMI codec for Azalia.

The optional settings are: [Disabled]; [Enabled].

System State after Power Failure

Use this item to select the system state when AC power is re-applied after a power loss.

The optional settings are: [Always Off]; [Always On]; [Former State].

***Note:** *The option [Always On] and [Former State] are affected by ERP function. Please disable ERP to support [Always On] and [Former State] function.*

3-9 Security Menu

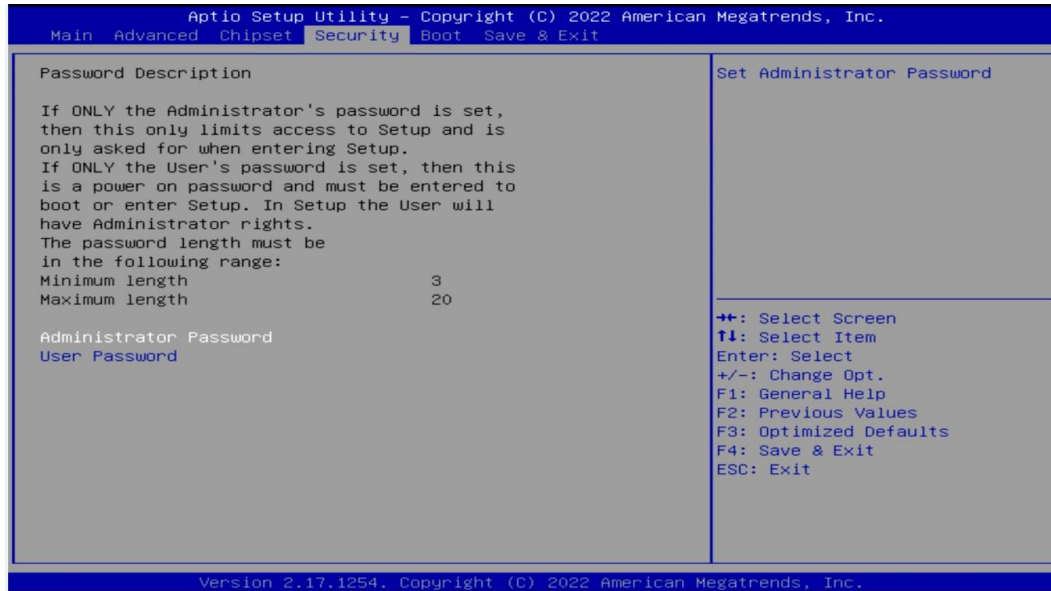

Security menu allow users to change administrator password and user password settings.

Administrator Password

If there is no password present on system, please press [Enter] to create new administrator password. If password is present on system, please press [Enter] to verify old password then to clear/change password. Press again to confirm the new administrator password.

User Password

If there is no password present on system, please press [Enter] to create new user password. If password is present on system, please press [Enter] to verify old password then to clear/change password. Press again to confirm the new user password.

3-10 Boot Menu



Setup Prompt Timeout

Use this item to Number of seconds to wait for setup activation key. 65535(0xFFFF) means indefinite waiting.

Bootup Numlock State

Use this item to select keyboard numlock state.

The optional settings are: [On]; [Off].

Quiet Boot

Use this item to enables or disables quiet boot option

The optional settings are: [Disabled]; [Enabled].

Boot Option Priorities

Boot Option #1

Use this item to decide system boot order from available options.

he optional settings are: [UEFI: Built-in EFI Shell]; [Disabled].

New Boot Option Policy

This item controls the placement of newly detected UEFI boot options.
The optional settings are: [Default]; [Place First]; [Place Last].

3-11 Save & Exit Menu

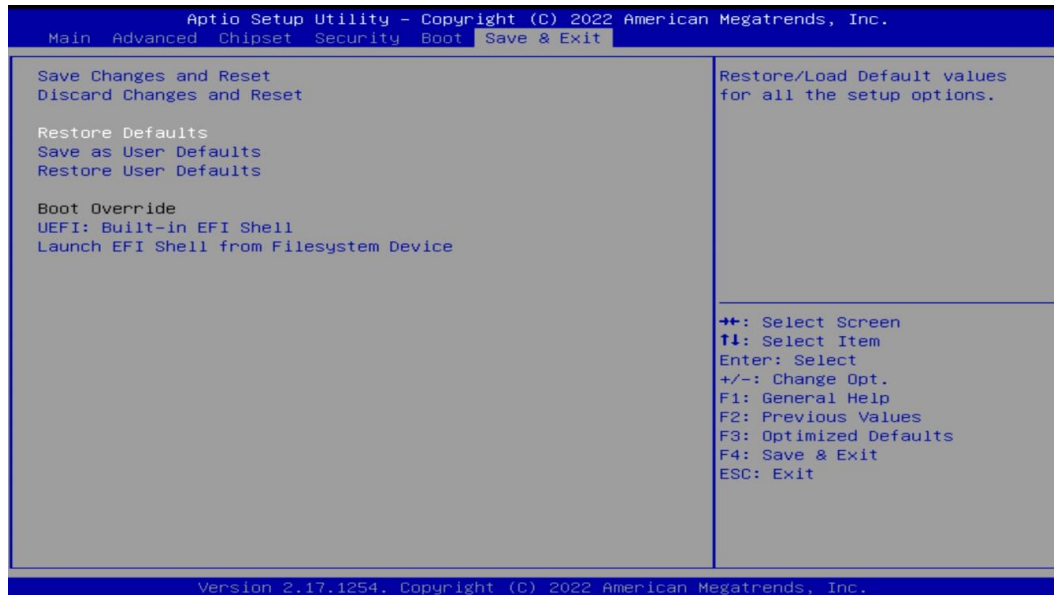

Save Changes and Reset

This item allows user to reset the system after saving the changes.

Discard Changes and Reset

This item allows user to reset the system without saving any changes.

Restore Defaults

Use this item to restore /load default values for all the setup options.

Save as User Defaults

Use this item to save the changes done so far as user defaults.

Restore User Defaults

Use this item to restore the user defaults to all the setup options.

Boot Override

UEFI: Built-in EFI Shell

Press this item to select the device as boot disk after save configuration and reset.

Launch EFI Shell from filesystem device

This item is used for attempts to launch EFI shell application from one of the available file system devices.