

NF692S6 Series

User's Manual

NO. G03-NF692S-F

Revision: 1.0

Release date: November 17, 2021

Trademark:

* Specifications and Information contained in this documentation are furnished for information use only, and are subject to change at any time without notice, and should not be construed as a commitment by manufacturer.

Environmental Protection Announcement

Do not dispose this electronic device into the trash while discarding. To minimize pollution and ensure environment protection of mother earth, please recycle.



TABLE OF CONTENT

ENVIRONMENTAL SAFETY INSTRUCTION.....	iii
USER'S NOTICE.....	iv
MANUAL REVISION INFORMATION.....	iv
ITEM CHECKLIST.....	iv
CHAPTER 1 INTRODUCTION OF THE MOTHERBOARD	
1-1 FEATURE OF MOTHERBOARD.....	1
1-2 SPECIFICATION.....	2
1-3 LAYOUT DIAGRAM.....	3
CHAPTER 2 HARDWARE INSTALLATION	
2-1 JUMPER SETTING.....	6
2-2 CONNECTORS, HEADERS AND WAFERS.....	8
2-2-1 CONNECTORS.....	8
2-2-2 HEADERS & WAFERS.....	11
CHAPTER 3 INTRODUCING BIOS	
3-1 ENTERING SETUP.....	17
3-2 BIOS MENU SCREEN.....	18
3-3 FUNCTION KEYS.....	19
3-4 GETTING HELP.....	19
3-5 MEMU BARS.....	19
3-6 MAIN MENU.....	20
3-7 ADVANCED MENU.....	21
3-8 CHIPSET MENU.....	33
3-9 SECURITY MENU.....	36
3-10 BOOT MENU.....	38
3-11 SAVE & EXIT MENU.....	39



Environmental Safety Instruction

- Avoid the dusty, humidity and temperature extremes. Do not place the product in any area where it may become wet.
- 0 to 60 centigrade is the suitable temperature. (The figure comes from the request of the main chipset)
- Generally speaking, dramatic changes in temperature may lead to contact malfunction and crackles due to constant thermal expansion and contraction from the welding spots' that connect components and PCB. Computer should go through an adaptive phase before it boots when it is moved from a cold environment to a warmer one to avoid condensation phenomenon. These water drops attached on PCB or the surface of the components can bring about phenomena as minor as computer instability resulted from corrosion and oxidation from components and PCB or as major as short circuit that can burn the components. Suggest starting the computer until the temperature goes up.
- The increasing temperature of the capacitor may decrease the life of computer. Using the close case may decrease the life of other device because the higher temperature in the inner of the case.
- Attention to the heat sink when you over-clocking. The higher temperature may decrease the life of the device and burned the capacitor.

USER'S NOTICE

COPYRIGHT OF THIS MANUAL BELONGS TO THE MANUFACTURER. NO PART OF THIS MANUAL, INCLUDING THE PRODUCTS AND SOFTWARE DESCRIBED IN IT MAY BE REPRODUCED, TRANSMITTED OR TRANSLATED INTO ANY LANGUAGE IN ANY FORM OR BY ANY MEANS WITHOUT WRITTEN PERMISSION OF THE MANUFACTURER.

THIS MANUAL CONTAINS ALL INFORMATION REQUIRED TO USE THIS MOTHER-BOARD SERIES AND WE DO ASSURE THIS MANUAL MEETS USER'S REQUIREMENT BUT WILL CHANGE, CORRECT ANY TIME WITHOUT NOTICE. MANUFACTURER PROVIDES THIS MANUAL "AS IS" WITHOUT WARRANTY OF ANY KIND, AND WILL NOT BE LIABLE FOR ANY INDIRECT, SPECIAL, INCIDENTAL OR CONSEQUENTIAL DAMAGES (INCLUDING DAMAGES FOR LOSS OF PROFIT, LOSS OF BUSINESS, LOSS OF USE OF DATA, INTERRUPTION OF BUSINESS AND THE LIKE).

PRODUCTS AND CORPORATE NAMES APPEARING IN THIS MANUAL MAY OR MAY NOT BE REGISTERED TRADEMARKS OR COPYRIGHTS OF THEIR RESPECTIVE COMPANIES, AND THEY ARE USED ONLY FOR IDENTIFICATION OR EXPLANATION AND TO THE OWNER'S BENEFIT, WITHOUT INTENT TO INFRINGE.

Manual Revision Information

Reversion	Revision History	Date
1.0	First Edition	November 17, 2021

Item Checklist

- Motherboard
- Cable(s)
- I/O Back panel shield

Chapter 1

Introduction of the Motherboard

1-1 Feature of Motherboard

- Onboard Intel® Apollo Lake Series Processor, with low power consumption and high performance
- Support 1* DDR3L 1866 MHz SO-DIMM, up to 8GB
- Support 1* PCIE 2.0 x1 sideways slot & 1* full-size Mini-PCIe slot
- Support 1 * SATAIII (6Gb) port & 1* full-size m-SATA slot
- Support 6* 10/100/1000 Base-TX Ethernet Ports
- support Bypass GbE (*optional for **NF692S6-345B1** Series*)
- Support USB 3.0 data transport demand
- Supports ACPI S3 Function
- Compliance with EuP Standard
- Support CPU Smart FAN
- Support Watchdog Technology

1-2 Specification

Spec	Description
Design	<ul style="list-style-type: none"> ● Mini-ITX form factor 6 layers; PCB size: 17.0x17.0cm
Embedded CPU	<ul style="list-style-type: none"> ● Intel® Apollo Lake series CPU <p><i>* for detailed CPU support information please visit our website</i></p>
Memory Socket	<ul style="list-style-type: none"> ● 1*DDR3L SO-DIMM slot ● Support DDR3L 1866 MHz SO-DIMM up to 8GB
Expansion Slot	<ul style="list-style-type: none"> ● 1* PCIE x1 slot by sideway(PCIE2) ● 1* Full-size Mini-PCle slot (MPE) only supports USB signal ● 1* SIM card slot (SIMCARD)
Storage	<ul style="list-style-type: none"> ● 1* SATA III 6G/s connector (SATA1) ● 1* Full-size mSATA slot (MSATA)
LAN Chip	<ul style="list-style-type: none"> ● Integrated with 6* Intel I211AT PCI-E Gigabit LAN chips ● Support Fast Ethernet LAN function of providing 10/100/1000Mbps Ethernet data transfer rate NF692S6-345B1 Series : support 1 pair (LAN3&LAN4) ByPass Gigabit LAN Ethernet
BIOS	<ul style="list-style-type: none"> ● AMI 128MB Flash ROM
Rear I/O	<ul style="list-style-type: none"> ● 1* RJ-45 COM port ● 2* USB 3.0 port ● 6* RJ-45 LAN port
Internal I/O	<ul style="list-style-type: none"> ● 1* 2-pin internal 12V DC-in power connector ● 1* SATA Power connector ● 1* CPU FAN connector ● 1* Front panel header ● 1* USB 2.0 header (Expansible to 2* USB 2.0 ports) ● 3* RS232 Serial port header ● 1* PS/2 keyboard & mouse header ● 1* HDMI port header ● 1* 8-pin LANLED header (LAN_LED1) ● 1* 4-pin LANLED header (LAN_LED2) ● 1* optional Bypass LED header (BYPASS1_LED) ● 1* SMBUS header ● 1* GPIO port header ● 1* SIM card wafer

1-3 Layout Diagram

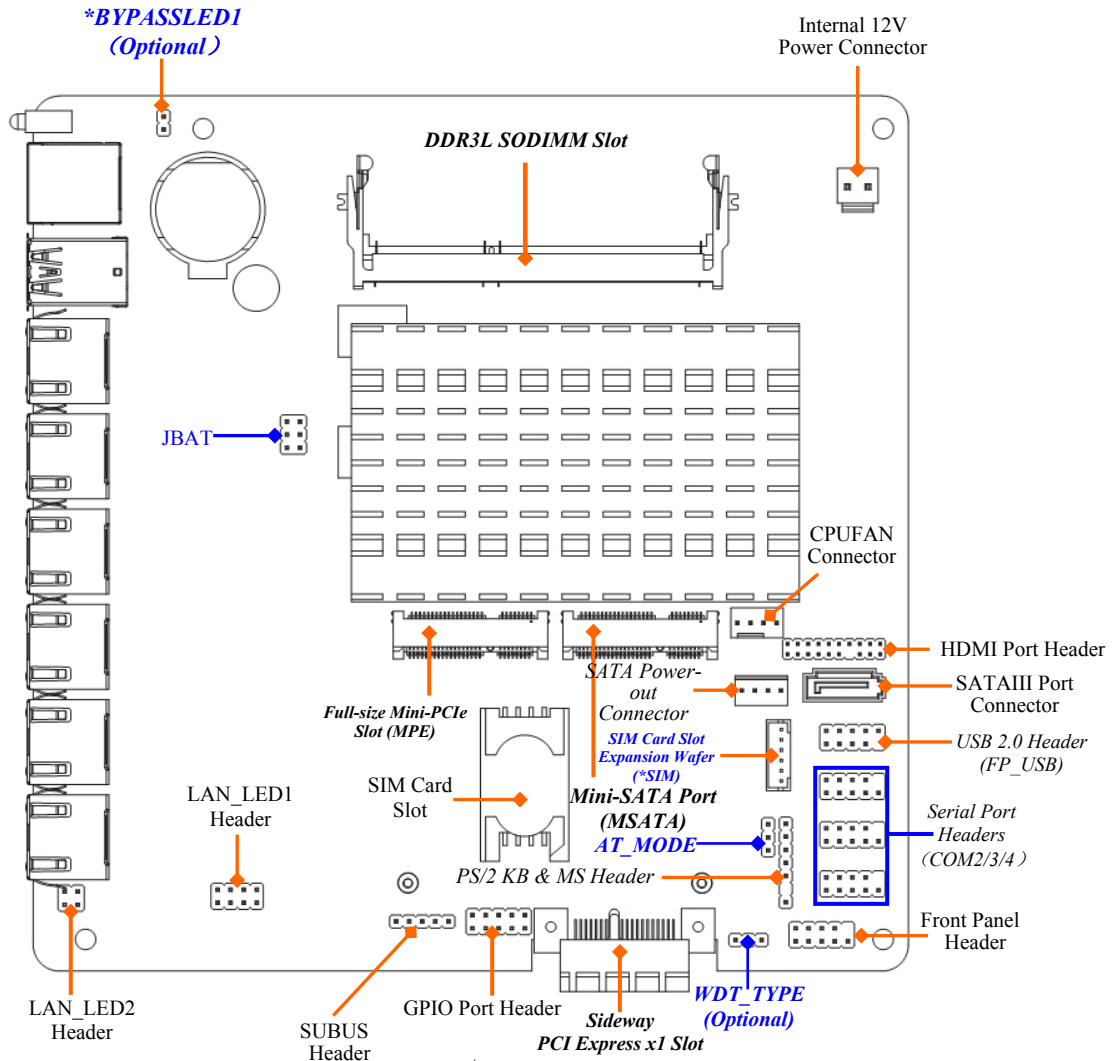

Motherboard Internal Diagram

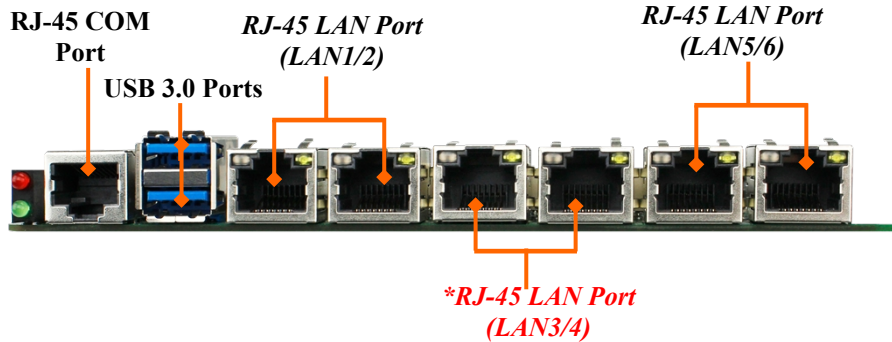

Note: 1. SIM card slot (BSIMCARD/expansion card from SIM wafer) only work when compatible SIM card installed & 3G LAN card installed in the full-size Mini-PCIE slot (MPE); 2. BSIMCARD and SIM wafer is optional, i.e., only one can work in the same time. 3. BYPASSLED1 header / WDT_TYPE header is optional. 4. The module should be DDR3L 1.35V SODIMM and not exceeding 8GB total capacity.

Rear IO Diagram



<i>Icon</i>	<i>Name</i>	<i>Function</i>
	RJ-45 LAN Port	This connector is standard RJ-45 LAN jack for Network connection.
	USB 3.0 Port	To connect USB keyboard, mouse or other devices compatible with USB specification. USB 3.0 ports supports up to 5Gbps data transfer rate.
	RJ-45 COM Port	Mainly for user to connect external MODEM or other devices that supports Serial Communications Interface.

Note: This manual serves as a common manual for **NF692S6-345B1/B2** & **NF692S6-345** series.

Their main differences are listed as below:

Model	BYPASS1_LED	Bypass LAN (on LAN3/LAN4)
NF692S6-345B1	Y	support
NF692S6-345	N	Not Support

***Note:** The pictures for illustration examples are mostly taken from the above layout diagram for **NF692S6-345B1** series, unless otherwise stated. Please refer to your actual product for specification reference.

Jumper

Jumper	Name	Description
JBAT	Pin (1-2): Clear CMOS RAM Settings Pin (3-4): Clear ME_RTC Pin (5-6): TXE Override	6-Pin Block (2.54 pitch)
AT_MODE	AT/ATX Mode Select	3-Pin Block (2.54 pitch)
WDT_TYPE (NF692S6-345B1)	WDT Type Select	3-Pin Block (2.54 pitch)

Connectors

Connector	Name
LAN1/2/3/4/5/6	RJ-45 LAN Connector X6
USB1	USB 3.0 Port Connector X2
RJ45_COM1	RJ45 COM Port Connector
DCIN	2-Pin Internal 12V DC-in Power Connector
SATA1	SATAIII Port Connector
SATAPW	SATA Power out Connector
CPUFAN1	CPU FAN Connector

Headers & Wafer

Header	Name	Description
FP	Front Panel Header(PWR LED/ HD LED /Power Button /Reset)	9-pin Block (2.54 pitch)
FP_USB	USB 2.0 Header	9-pin Block (2.54 pitch)
COM2	RS232/422/485 Serial Port Header	9-pin Block (2.54 pitch)
COM3/4	RS232 Serial Port Header	9-pin Block (2.54 pitch)
HDMI	HDMI Port Header	19-pin Block (2.0 pitch)
PS2KBMS	PS/2 Keyboard & Mouse Header	6-pin Block (2.54 pitch)
SMBUS	SMBUS Header	5-pin Block (2.54 pitch)
GPIO_CON	GPIO Header	10-pin Block (2.54 pitch)
LAN_LED1	LAN1/2/3/4 Activity LED Header	8-pin Block (2.54 pitch)
LAN_LED2	LAN5/6 Activity LED Header	4-pin Block (2.54 pitch)
SIM	SIM Card Slot Wafer	6-pin Block (2.0 pitch)
BYPASSLED1	LAN3&Lan4 Bypass Mode LED Header	2-pin Block (2.54 pitch)

***Note:** BYPASSLED1 & WDT_TYPE are optional to NF692S6-345B1 series.

Chapter 2

Hardware Installation

2-1 Jumper Setting

Pin 1&2 of JBAT (6-pin): Clear CMOS RAM Setting (2.54 pitch)

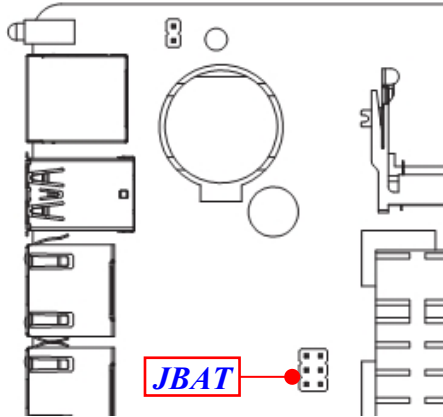

Pin (1&2) of JBAT → Clear CMOS

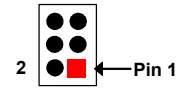

1-2 Open: Normal(Default);

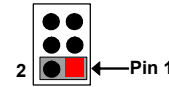

1-2 Closed: Clear CMOS(One Touch).

Pin 3&4 of JBAT (6-pin): Clear ME_RTC (2.54 pitch)

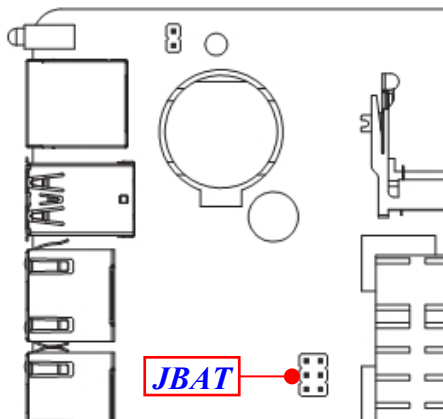

Pin (3&4) of JBAT → Clear ME_RTC

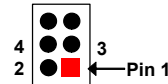

3-4 Open: Normal(Default);

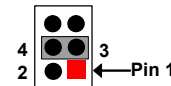

3-4 Closed: Clear ME_RTC (One Touch).

Pin 5&6 of JBAT (6-pin): TXE Override Function Select (2.54 pitch)

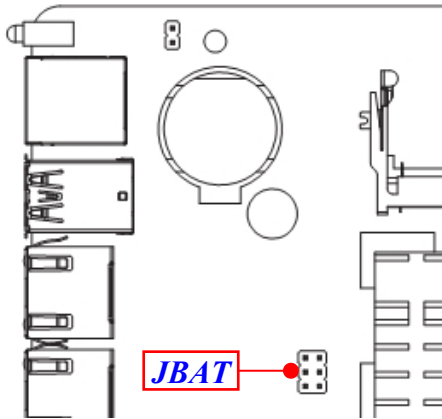

Pin (5&6) of JBAT → TXE Override

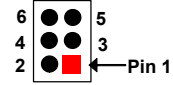

5-6 Open: Normal(Default);

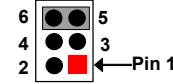

5-6 Closed: TXE Override(One Touch).

AT_MODE (3-pin): AT Mode/ATX Mode Select (2.54 pitch)

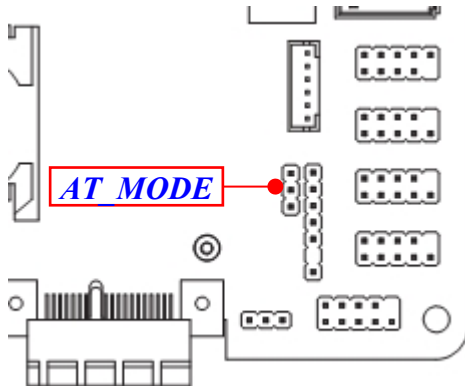

AT_MODE → ATX/AT Mode Select



1-2 Closed: ATX Mode Selected;



2-3 Closed: AT Mode Selected.

***ATX Mode Selected:** Press power button to power on after power input ready;
AT Mode Selected: Directly power on as power input ready.

WDT_TYPE (3-pin): WDT Type Select (2.54 pitch)

WDT_TYPE → WDT Type Select

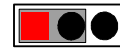
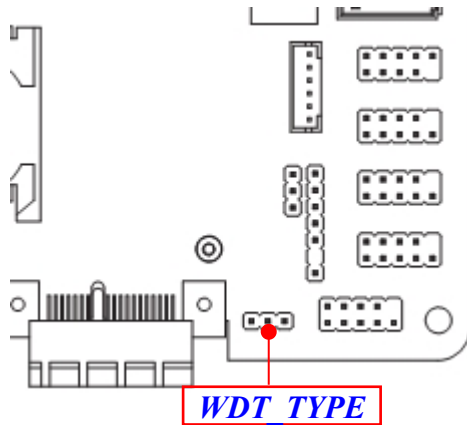

1 3

1-2 Close: WDT for Bypass;



1 3

2-3 Close: WDT for System Reset.

2-2 Connectors, Headers and Wafers

2-2-1 Connectors

(1) RJ45_COM1(8-pin block): RJ-45 COM Port Connector for Console

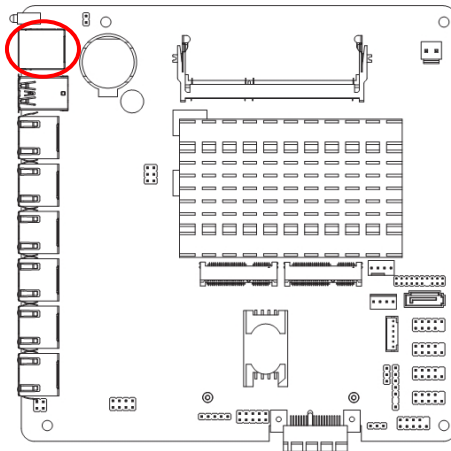

RJ45_COM1

Pin No.	Definition
1	RTS
2	DTR
3	TXD
4	GND
5	NC
6	RXD
7	DSR
8	CTS

(2) DCIN1(2-pin) : Internal 12V DC-in power connector

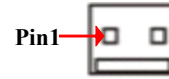
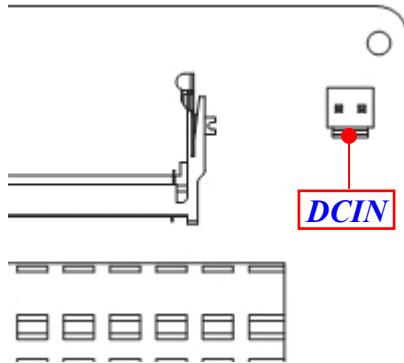

Pin No.	Definition
1	+12V DC_IN
2	GND

(3) SATA1 (7-pin): SATA III Port Connector

SATA1 is a high-speed SATAIII port that supports 6GB/s transfer rate.

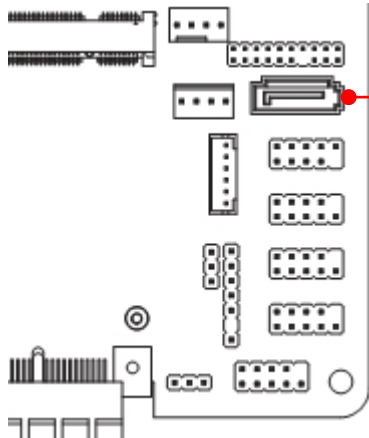

SATA1

Pin No.	Definition
1	GND
2	TXP
3	TXN
4	GND
5	RXN
6	RXP
7	GND

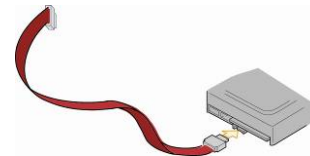

(4) SATAPW(4-pin): SATA Power Out Connector (2.54 pitch)

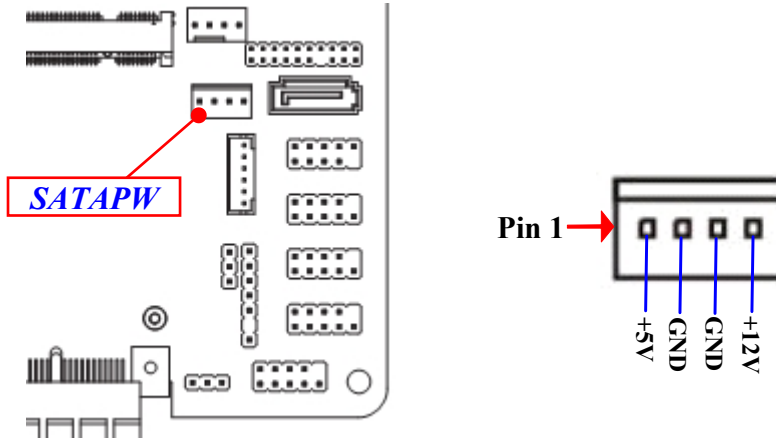

Warning: Make sure that Pin-1 of compatible SATA Power connector is inserted into corresponding Pin-1 of SATAPW connector to avoid possible damage to the board and hard disk driver!

(5) CPUFAN1 (4-pin): CPU Fan Connector (2.54 pitch)

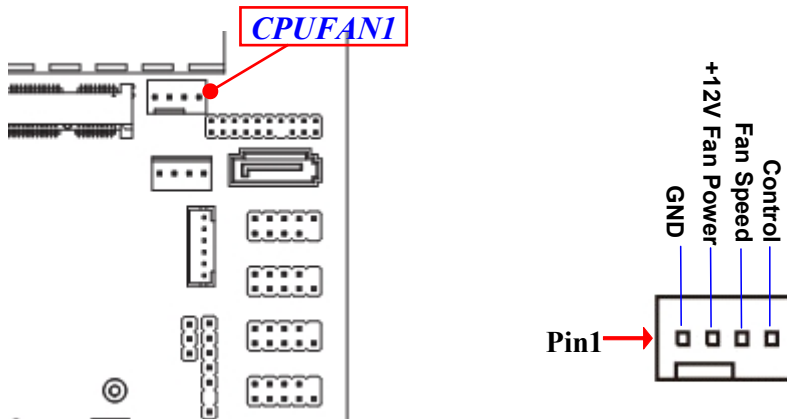

2-2-2 Headers & Wafers

(1) FP (9-pin): Front Panel Header (2.54 pitch)

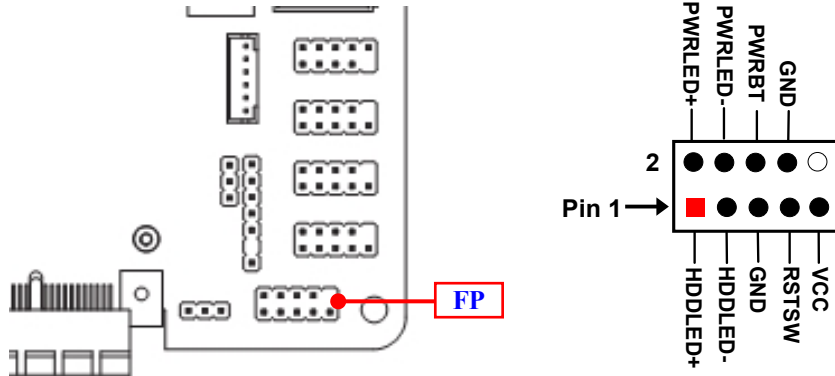

(2) FP_USB (9-pin): USB 2.0 Port Header (2.54 pitch)

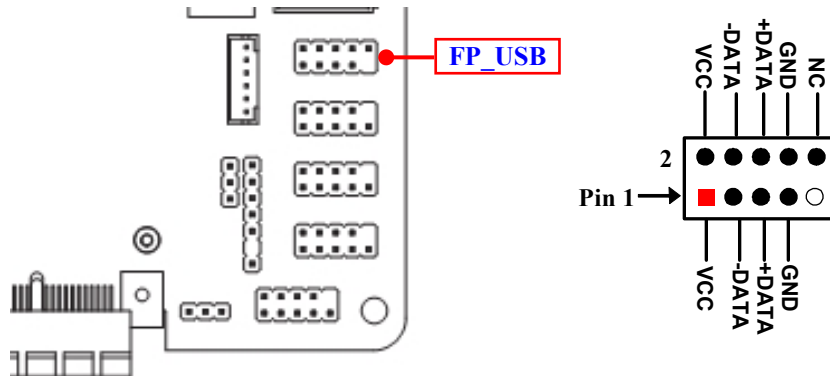

(3) COM2/3/4 (9-pin): Serial Port Headers (2.54 pitch)

COM2: RS232/422/485 Serial Port Header;
COM1/3/4: RS232 Serial Port Header.

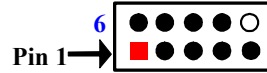
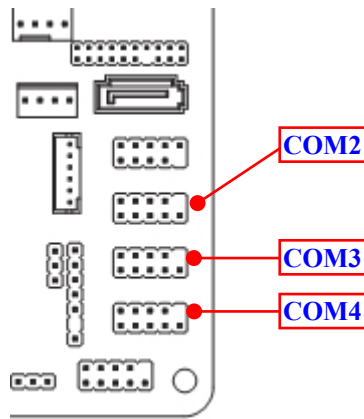

Pin NO.	RS232	*RS422	*RS485
Pin 1	DCD	TX-	DATA-
Pin 2	RXD	TX+	DATA+
Pin 3	TXD	RX+	NC
Pin 4	DTR	RX-	NC
Pin 5	GND	GND	GND
Pin 6	DSR	NC	NC
Pin 7	RTS	NC	NC
Pin 8	CTS	NC	NC
Pin 9	RI	NC	NC

***Notice:** RS422, RS485 function is supported by COM2 header only, with compatible COM cable for RS422 or RS 485 function. User also needs to go to BIOS to set 'Transmission Mode Select' for COM2 (refer to Page 23).

(4) PS2KBMS (6-pin): PS/2 Keyboard & Mouse Header (2.54 pitch)

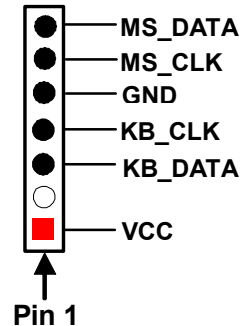
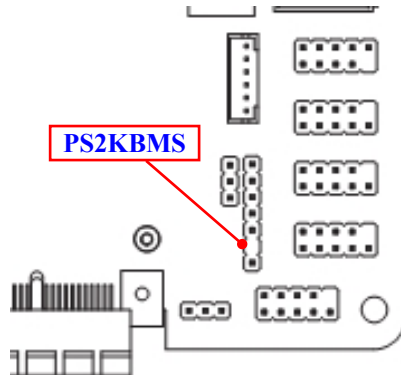

(5) SMBUS (5-Pin): SM BUS Header (2.54 pitch)

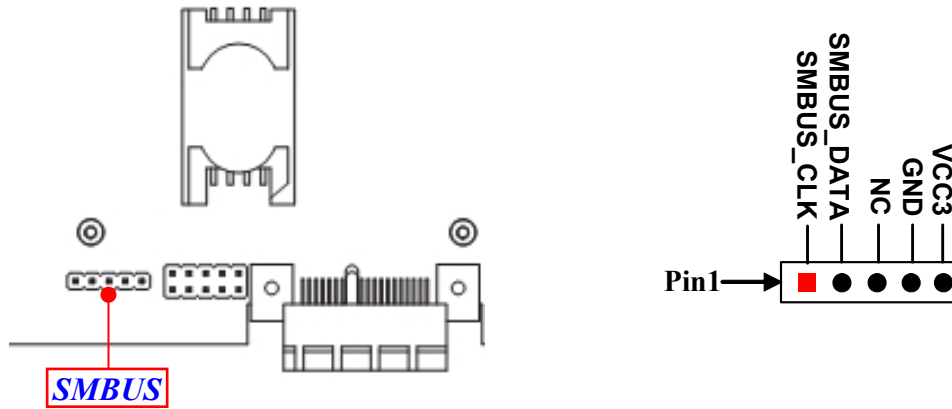

(6) GPIO_CON (10-pin): GPIO Port Header (2.54 pitch)

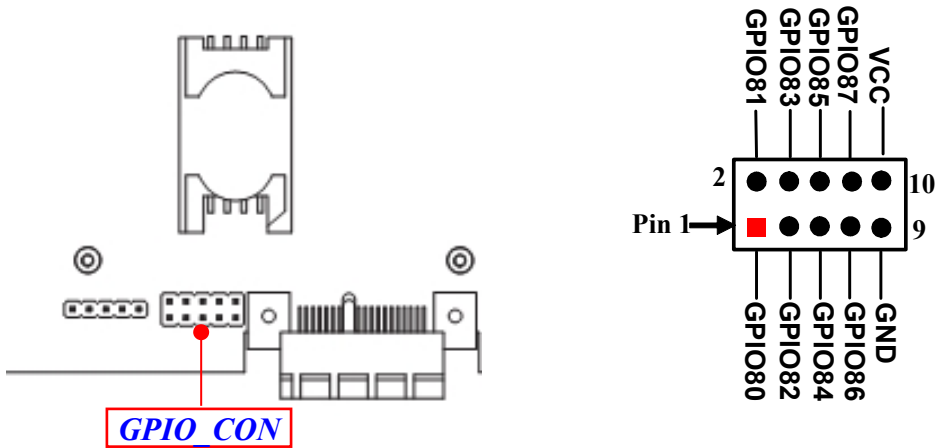

(7) LAN_LED2(4-pin): LAN5 & LAN6 Activity LED Header (2.54 pitch)

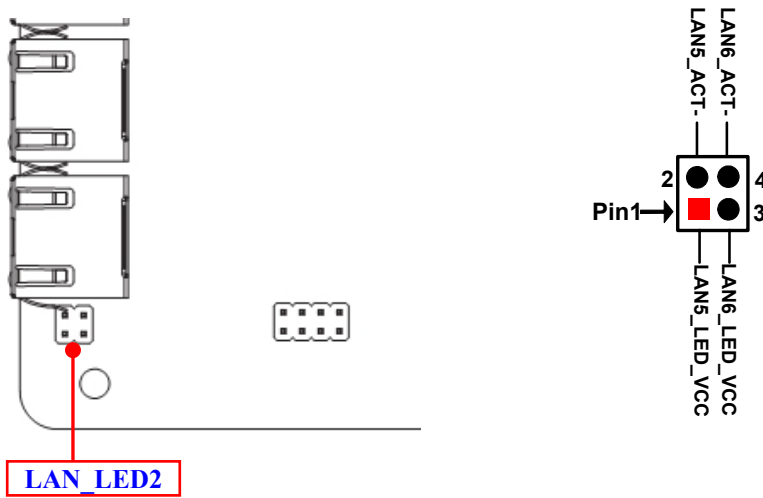

(8) LAN_LED1(8-pin): LAN1 & LAN2 & LAN3 & LAN4 Activity LED Header (2.54 pitch)

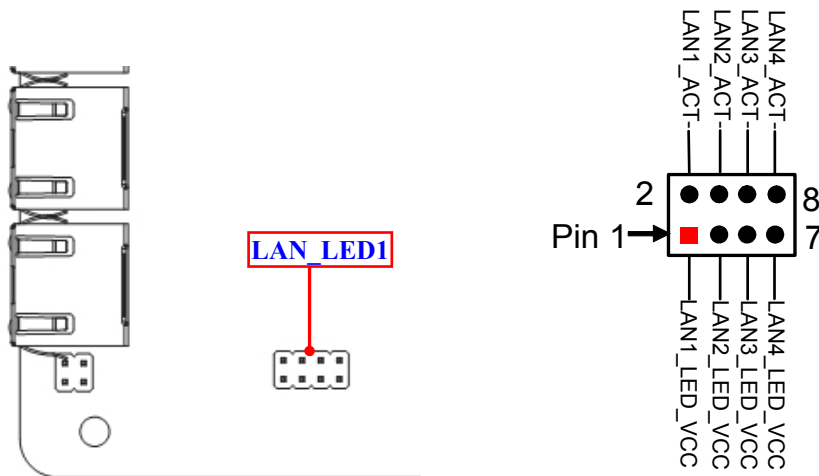

(9) BYPASSLED1(2-pin): LAN3 & LAN4 Bypass Mode LED Header (2.54 pitch)

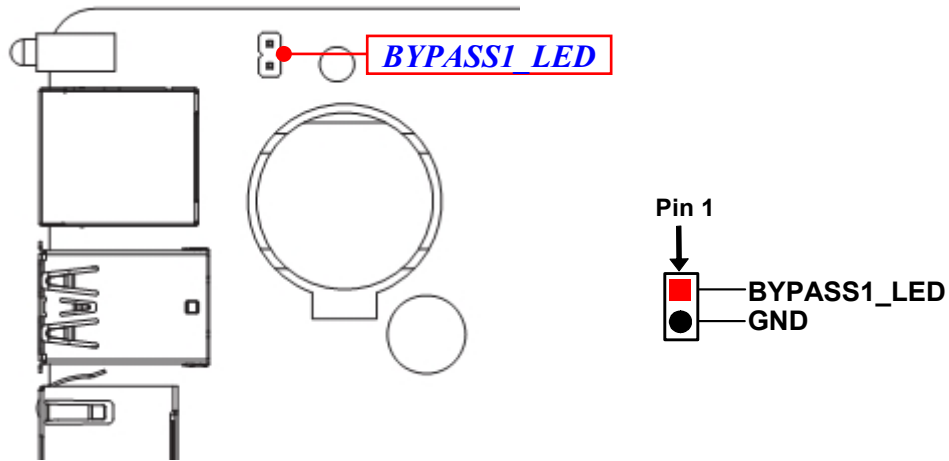

***Note:** BYPASSLED1 is only optional for **NF692S6-345B1** series that support Bypass Mode for external Bypass LED connection.

Bypass Led	On	Off
		<i>LAN3&LA4 Bypass</i>

(10) HDMI (19-pin): HDMI Port Header (2.0 pitch)

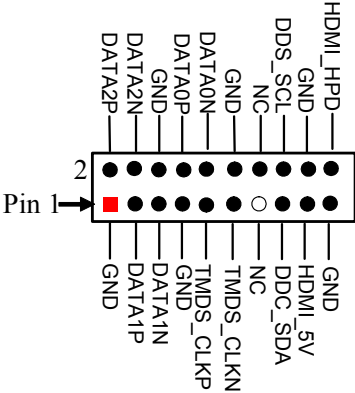
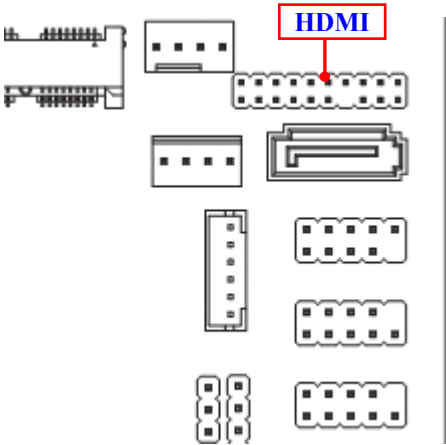

(11) SIM (6-pin): SIM Card Expansion Wafer (2.0 pitch)

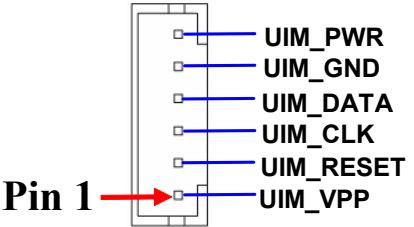
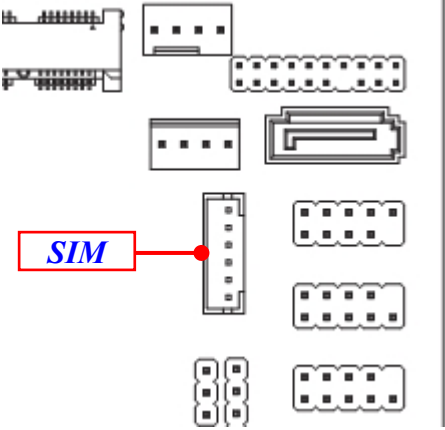

Chapter 3

Introducing BIOS

Notice! The BIOS options in this manual are for reference only. Different configurations may lead to difference in BIOS screen and BIOS screens in manuals are usually the first BIOS version when the board is released and may be different from your purchased motherboard. Users are welcome to download the latest BIOS version form our official website.

The BIOS is a program located on a Flash Memory on the motherboard. This program is a bridge between motherboard and operating system. When you start the computer, the BIOS program will gain control. The BIOS first operates an auto-diagnostic test called POST (power on self test) for all the necessary hardware, it detects the entire hardware device and configures the parameters of the hardware synchronization. Only when these tasks are completed done it gives up control of the computer to operating system (OS). Since the BIOS is the only channel for hardware and software to communicate, it is the key factor for system stability, and in ensuring that your system performance as its best.

3-1 Entering Setup

Power on the computer and by pressing immediately allows you to enter Setup. If the message disappears before your respond and you still wish to enter Setup, restart the system to try again by turning it OFF then ON or pressing the “RESET” button on the system case. You may also restart by simultaneously pressing <Ctrl>, <Alt> and <Delete> keys. If you do not press the keys at the correct time and the system does not boot, an error message will be displayed and you will again be asked to

Press **** to enter Setup; press **< F7>** for Pop Menu.

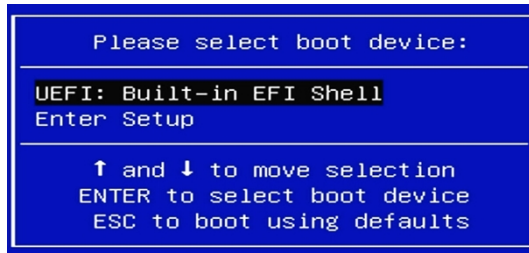

3-2 BIOS Menu Screen

The following diagram show a general BIOS menu screen:

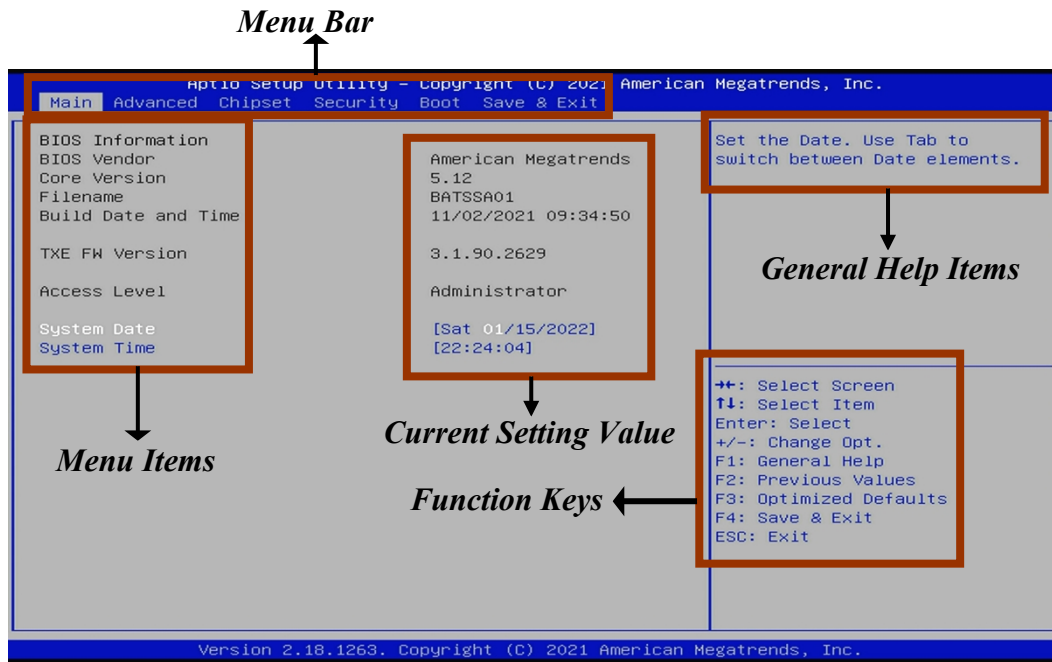

BIOS Menu Screen

3-3 Function Keys

In the above BIOS Setup main menu of, you can see several options. We will explain these options step by step in the following pages of this chapter, but let us first see a short description of the function keys you may use here:

- Press ←→ (left, right) to select screen;
- Press ↑↓ (up, down) to choose, in the main menu, the option you want to confirm or to modify.
- Press <Enter> to select.
- Press <+>/<-> keys when you want to modify the BIOS parameters for the active option.
- [F1]: General help.
- [F2]: Previous value.
- [F3]: Optimized defaults.
- [F4]: Save & Exit.
- Press <Esc> to quit the BIOS Setup.

3-4 Getting Help

Main Menu

The on-line description of the highlighted setup function is displayed at the top right corner the screen.

Status Page Setup Menu/Option Page Setup Menu

Press [F1] to pop up a small help window that describes the appropriate keys to use and the possible selections for the highlighted item. To exit the Help Window, press <Esc>.

3-5 Menu Bars

There are six menu bars on top of BIOS screen:

Main	To change system basic configuration
Advanced	To change system advanced configuration
Chipset	To change chipset configuration
Security	Password settings
Boot	To change boot settings
Save & Exit	Save setting, loading and exit options.

User can press the right or left arrow key on the keyboard to switch from menu bar. The selected one is highlighted.

3-6 Main Menu

Main menu screen includes some basic system information. Highlight the item and then use the <+> or <-> and numerical keyboard keys to select the value you want in each item.

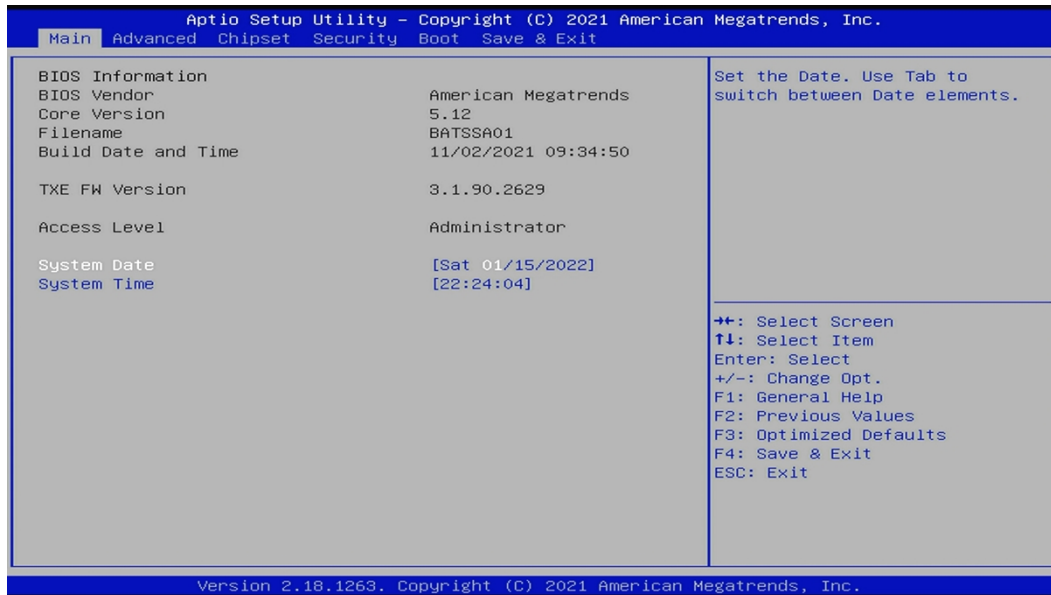

System Date

Set the date. Please use [Tab] to switch between data elements.

System Time

Set the time. Please use [Tab] to switch between time elements.

3-7 Advanced Menu

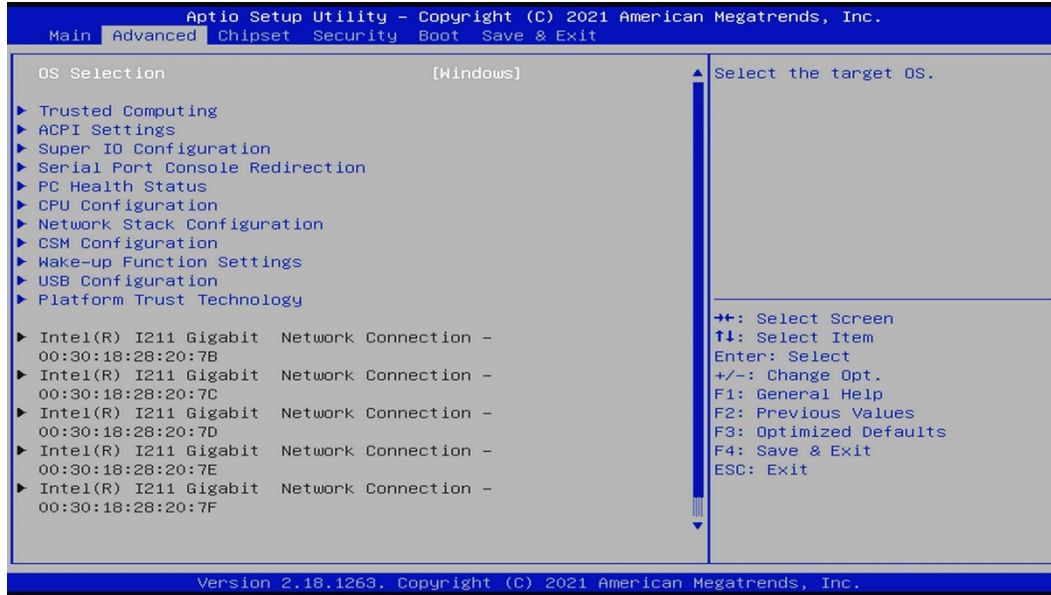

OS Selection

The optional settings: [Windows]; [Intel Linux]; [MSDOS].

*** Note:** User need to go to this item to select the OS mode before installing corresponding OS driver, otherwise problems will occur when installing the driver.

▶ Trusted Computing

Press [Enter] to enable or disable 'Security Device Support'.

Configuration

Security Device Support

Use this item to enable or disable BIOS support for security device.

*** Note:** O.S. will not show Security Device. TCG EFI protocol and INT1A interface

will not be available.

The optional settings: [Disabled]; [Enabled].

SHA-1 PCR Bank

Use this item to enable or disable SHA-1PCR Bank.

The optional settings: [Disabled]; [Enabled].

SHA256 PCR Bank

Use this item to enable or disable SHA256 PCR Bank.

The optional settings: [Disabled]; [Enabled].

SHA384 PCR Bank

Use this item to enable or disable SHA384 PCR Bank.

The optional settings: [Disabled]; [Enabled].

Pending Operation

Use this item to set an operation for the Security Device.

*Note: User's computer will reboot during restart in order to change State of Security Device.

The optional settings: [None]; [TPM Clear].

▶ **ACPI Settings**

Press [Enter] to make settings for the following sub-item:

ACPI Settings

ACPI Sleep State

Use this item to select the highest ACPI sleep state the system will enter when the suspend button is pressed.

The optional settings are: [Suspend Disabled]; [S3 (Suspend to RAM)].

▶ **Super I/O Configuration**

Press [Enter] to make settings for the following sub-items:

Super IO Configuration

▶ **Serial Port 1 Configuration/ Serial Port 3 Configuration/ Serial Port 4 Configuration**

Press [Enter] to make settings for the following items:

Serial Port

Use this item to enable or disable serial port (COM).

The optional settings are: [Disabled]; [Enabled].

When set as [Enabled], the following sub-items shall appear:

Change Settings

Use this item to select an optimal setting for super IO device.

The optional settings are: [Auto]; [IO=3F8h; IRQ=4]; [IO=2F8h; IRQ=3]; [IO=3E8h; IRQ=4]; [IO=2E8h; IRQ=3] for '**Serial Port 1 Configuration**'.

The optional settings are: [Auto]; [IO=3F8h; IRQ=10]; [IO=2F8h; IRQ=10]; [IO=3E8h; IRQ=10]; [IO=2E8h; IRQ=10]; [IO=2F0h; IRQ=10]; [IO=2E0h; IRQ=10] for '**Serial Port 3 Configuration**' & '**Serial Port 4 Configuration**'.

▶ **Serial Port 2 Configuration**

Press [Enter] to make settings for the following items:

Serial Port

Use this item to enable or disable serial port (COM).

The optional settings are: [Disabled]; [Enabled].

When set as [Enabled], the following sub-items shall appear:

Change Settings

Use this item to select an optimal settings fro Super IO Device.

The optional settings are: [Auto]; [IO=3F8h; IRQ=4]; [IO=2F8h; IRQ=3]; [IO=3E8h; IRQ=4]; [IO=2E8h; IRQ=3] for '**Serial Port 2 Configuration**'.

Transmission Mode Select

The optional settings are: [RS422]; [RS232]; [RS485].

Mode Speed Select

The optional settings are: [RS232/RS422/RS485=250kbps]; [RS232=1Mbps, RS422/RS485=10Mbps].

ERP Support

Use this item to enable or disable Energy-Related Products function.

The optional settings: [Enabled]; [Disabled].

This item should be set as [Disabled] if you wish to have all active wake-up functions.

PS2 KB/MS Connect

Use this item to set PS2 connect primary devices.

The optional settings are: [Keyboard First]; [Mouse First].

***Note:** This item should be set as [**Disabled**] if you wish to have all active wake-up functions.

WatchDog Reset Timer

Use this item to enable or disable WDT reset function. When set as [Enabled], the following sub-items shall appear:

WatchDog Reset Timer Value

User can set a value in the range of [10] to [255].

WatchDog Reset Timer Unit

The optional settings are: [Sec.]; [Min.].

WatchDog Wake-up Timer

This item support WDT wake-up.

The optional settings are: [Enabled]; [Disabled].

When set as [Enabled], the following sub-items shall appear:

WatchDog Wake-up Timer Value

User can select a value in the range of [10] to [4095] seconds when ‘**WatchDog Wake-up Timer Unit**’ set as [Sec]; or in the range of [1] to [4095] minutes when ‘**WatchDog Wake-up Timer Unit**’ set as [Min].

WatchDog Wake-up Timer Unit

The optional settings are: [Sec.]; [Min.].

ATX Power Emulate AT Power

This item displays current Emulate AT Power Status, motherboard power On/Off control by power supply. User needs to select ‘AT or ATX Mode’ on MB jumper at first (refer to **Page 7**, Jumper AT_MODE Pin1-2 of ATX Mode & Pin 2-3 of AT Mode Select).

▶ **Serial Port Console Redirection**

COM1

Console Redirection

The optional settings: [Disabled]; [Enabled]. When set as [Enabled], the following sub-items shall appear:

▶ **Console Redirection Settings**

The settings specify how the host computer and the remote computer (which the user is using) will exchange data. Both computers should have the same or compatible settings.

Press [Enter] to make settings for the following items:

Terminal Type

The optional settings: [VT100]; [VT100+]; [VT-UTF8]; [ANSI].

Emulation: [ANSI]: Extended ASCII char set; [VT100]: ASCII char set; [VT100+]: Extends VT100 to support color, function keys, etc.; [VT-UTF8]: Uses UTF8 encoding to map Unicode chars onto 1 or more bytes.

Bits per second

Use this item to select serial port transmission speed. The speed must be matched on the other side. Long or noisy lines may require lower speeds.

The optional settings: [9600]; [19200]; [38400]; [57600]; [115200].

Data Bits

The optional settings: [7]; [8].

Parity

A parity bit can be sent with the data bits to detect some transmission errors.

The optional settings: [None]; [Even]; [Odd]; [Mark]; [Space].

[Even]: parity bit is 0 if the num of 1's in the data bits is even; [Odd]: parity bit is 0 if num of 1's in the data bits is odd; [Mark]: parity bit is always 1; [Space]: Parity bit is always 0; [Mark] and [Space] Parity do not allow for error detection.

Stop Bits

Stop bits indicate the end of a serial data packet. (A start bit indicates the beginning). The standard setting is 1 stop bit. Communication with slow devices may require more than 1 stop bit.

The optional settings: [1]; [2].

Flow Control

Flow control can prevent data loss from buffer overflow. When sending data, if the receiving buffers are full, a "stop" signal can be sent to stop the data flow. Once the buffers are empty, a "start" signal can be sent to re-start the flow. Hardware flow control uses two wires to send start/stop signals.

The optional settings: [None]; [Hardware RTS/CTS].

VT-UTF8 Combo Key Support

Use this item to enable VT-UTF8 Combination Key Support for ANSI/VT100 terminals.

The optional settings: [Disabled]; [Enabled].

Recorder Mode

With this mode enable only text will be sent. This is to capture Terminal data.

The optional settings: [Disabled]; [Enabled].

Resolution 100x31

Use this item to enable or disable extended terminal resolution.

The optional settings: [Disabled]; [Enabled].

Legacy OS Redirection Resolution

On Legacy OS, the Number of Rows and Columns supported redirection.

The optional settings: [80x24]; [80x25].

Putty KeyPad

Use this item to select FunctionKey and KeyPad on Putty.

The optional settings: [VT100]; [Intel Linux]; [XTERMR6]; [SCO]; [ESCN]; [VT400].

Redirection After BIOS POST

The optional settings are: [Always Enable]; [BootLoader].

When Bootloader is selected, then Legacy Console Redirection is disabled before booting to legacy OS. When Always Enable is selected, then Legacy Console is enabled for legacy OS. Default setting for this option is set to Always Enable.

Serial Port for Out-of-Band Management/

Windows Emergency Management Services (EMS)

Console Redirection

The optional settings: [Disabled]; [Enabled]. When set as [Enabled], the following sub-items shall appear:

► Console Redirection Settings

The settings specify how the host computer and the remote computer (which the user is using) will exchange data. Both computers should have the same or compatible settings.

Press [Enter] to make settings for the following items:

Out-of-Band Mgmt Port

The optional setting is: [COM1].

Terminal Type

The optional settings: [VT100]; [VT100+]; [VT-UTF8]; [ANSI].

[VT-UTF8] is the preferred terminal type for out-of-band management. The next best choice is [VT100+] and then [VT100]. See above, in Console Redirection

Settings page, for more help with Terminal Type/Emulation.

Bits per second

Use this item to select serial port transmission speed. The speed must be matched on the other side. Long or noisy lines may require lower speeds.

The optional settings: [9600]; [19200]; [57600]; [115200].

Flow Control

Flow control can prevent data loss from buffer overflow. When sending data, if the receiving buffers are full, a “stop” signal can be sent to stop the data flow.

Once the buffers are empty, a “start” signal can be sent to re-start the flow.

Hardware flow control uses two wires to send start/stop signals.

The optional settings: [None]; [Hardware RTS/CTS]; [Software Xon/Xoff].

Data Bits

The default setting is: [8].

**This item may or may not show up, depending on different configuration.*

Parity

The default setting is: [None].

**This item may or may not show up, depending on different configuration.*

Stop Bits

The default setting is: [1].

**This item may or may not show up, depending on different configuration.*

▶ **PC Health Status**

Press [Enter] to view current hardware health status, set shutdown temperature, or make further settings in ‘**Smart Fan Configuration**’.

▶ **SmartFan Configuration**

Press [Enter] to make settings for SmartFan Configuration:

SmartFAN Configuration

CPUFAN Smart Mode

Use this item to enable or disable CPUFAN smart mode.

The optional settings are: [Disabled]; [Enabled].

When set as [Enabled], the following sub-items shall appear:

CPUFAN Full-Speed Temperature

Use this item to set CPUFAN full speed temperature. Fan will run at full speed when above this temperature.

CPUFAN Full-Speed Duty

Use this item to set CPUFAN full speed duty. Fan will run at full speed when above the pre-set duty.

CPUFAN Idle-Speed Temperature

Use this item to set CPUFAN idle speed temperature. Fan will run at idle speed when below this temperature.

CPUFAN Idle-Speed Duty

Use this item to set CPUFAN idle speed duty. Fan will run at idle speed when below the pre-set duty.

▶ **CPU Configuration**

Press [Enter] to view current CPU configuration and make settings for the following sub-items:

VT-d

Use this item to enable or disable CPU VT-d.

The optional settings: [Enabled]; [Disabled].

EIST

Use this item to enable or disable Intel SpeedStep.

The optional settings: [Disabled]; [Enabled].

Turbo Mode

Use this item to enable or disable Turbo Mode.

The optional settings: [Disabled]; [Enabled].

C States

Use this item to enable or disable CPU C states. The optional settings: [Disabled]; [Enabled].

When set as [Enabled], users can make more settings for the following sub-items:

Enhanced C-states

Use this item to enable or disable C1E. When set as [Enabled], CPU will switch to minimum speed when all cores enter C-state.

The optional settings: [Disabled]; [Enabled].

Max Package C State

This item controls Max Package C state that the processor will support.

The optional settings: [PC2]; [PC1]; [C0].

Max Core C State Limit

This item controls the max Core C State that cores will support.

The optional settings: [Fused Value]; [Core C10]; [Core C9] [Core C8]; [Core C 7]; [Core C 6]; [Core C1]; [Unlimited].

▶ **Network Stack Configuration**

Press [Enter] to go to '**Network Stack**' screen to make further settings.

Network Stack

Use this item to enable or disable UEFI Network Stack.

The optional settings are: [Enabled]; [Disabled].

When set as [Enabled], the following sub-items shall appear:

Ipv4 PXE Support

Use this item to enable Ipv4 PXE Boot Support. When set as [Disabled], Ipv4 boot option will not be created.

The optional settings are: [Disabled]; [Enabled].

Ipv6 PXE Support

Use this item to enable Ipv6 PXE Boot Support. When set as [Disabled], Ipv6 boot option will not be created.

The optional settings are: [Disabled]; [Enabled].

PXE boot wait time

Use this item to set wait time to press [ESC] key to abort the PXE boot.

The optional setting range is from [0] to [5].

Media Detect Count

Use this item to set number of times presence of media will be checked.

The optional setting range is from [1] to [50].

▶ **CSM Configuration**

Press [Enter] to make settings for the following sub-items:

Compatibility Support Module Configuraton

Boot option filter

This item controls Legacy/UEFI ROMs priority.

The optional settings are: [UEFI and Legacy]; [Legacy only]; [UEFI only].

Network

This item controls the execution of UEFI and Legacy PXE OpROM.

The optional settings are: [Do not launch]; [UEFI]; [Legacy].

Storage

This item controls the execution of UEFI and Legacy Storage OpROM.

The optional settings are: [Do not launch]; [UEFI]; [Legacy].

Video

This item controls the execution of UEFI and Legacy Video OpROM.

The optional settings are: [UEFI]; [Legacy].

Other PCI devices

This item determines OpROM execution policy for devices other than Network, storage or video.

The optional settings are: [Do not launch]; [UEFI]; [Legacy].

▶ **Wake-up Function Settings**

Press [Enter] to make settings for the following sub-items:

Wake-up System with Fixed Time

Use this item to enable or disable system wake-up by RTC alarm.

The optional settings are: [Disabled]; [Enabled].

When set as [Enabled], the following items shall appear:

Wake-up Hour

Use this item to select 0-23. For example enter 3 for 3am and 15 for 3pm.

Wake-up Minute

Use this item to select 0-59.

Wake-up Second

Use this item to select 0-59.

Wake-up System with Dynamic Time

Use this item to enable or disable system wake on alarm event.

System will wake on the current time + Increase minutes.

The optional settings are: [Disabled]; [Enabled].

When set as [Enabled], the following items shall appear:

Wake-up Time Increase

Use this item to select 1-60 minute(s).

PS2 KB/MS Wake-Up from S3-S5

Use this item to enable or disable PS2 KB/MS device from S3-S5 Wake-up.

The optional settings: [Disabled]; [Enabled].

**Note: This item is only supported when 'ERP Support' is set as [Disabled].*

USB Wake-up from S4

Use this item to enable or disable USB device from S4 Wake-up.

The optional settings: [Enabled]; [Disabled].

**Note: USB Wake-up is affected by ERP function in S4. Please disable 'ERP*

Support' before activating this function in S4.

▶ **USB Configuration**

Press [Enter] to make settings for the following sub-items:

USB Configuration

Legacy USB Support

Use this item to enable Legacy USB support.

The optional settings are: [Enabled]; [Disabled]; [Auto].

[Enabled]: To enable legacy USB support.

[Disabled]: To keep USB devices available only for EFI specification,

[Auto]: To disable legacy support if no USB devices are connected.

XHCI Hand-off

This is a workaround for OSeS without XHCI hand-off support. The XHCI ownership change should be claimed by XHCI driver.

The optional settings are: [Enabled]; [Disabled].

USB Mass Storage Driver Support

Use this item to enable or disable USB mass storage driver support.

The optional settings are: [Disabled]; [Enabled].

USB Hardware Delays and Time-outs:

USB Transfer Time-out

Use this item to set the time-out value for control, bulk, and interrupt transfers.

The optional settings are: [1 sec]; [5 sec]; [10 sec]; [20 sec].

Device Reset Time-out

Use this item to set USB mass storage device start unit command time-out.

The optional settings are: [10 sec]; [20 sec]; [30 sec]; [40 sec].

Device Power-up Delay

Use this item to set maximum time the device will take before it properly reports itself to the host controller.

The optional settings: [Auto]; [Manual].

'Auto' uses default value: for a root port it is 100 ms, for a hub port the delay is taken from hub descriptor.

Select [Manual] you can set value for the following sub-item: '**Device Power-up Delay in Seconds**'.

Device Power-up Delay in Seconds

The delay range is from [1] to [40] seconds, in one second increments.

▶ **Platform Trust Technology**

Press [Enter] to make settings for the following sub-items:

TPM configuration

fTPM

Use this item to enable or disable fTPM.

The optional settings are: [Disabled]; [Enabled].

▶ **Intel(R) I211 Gigabit Network Connection-:XX:XX:XX:XX:XX:XX/...**

Use this item to get driver information and configure Intel(R) I211 gigabit network connections.

▶ **Intel(R) I211 Gigabit Network Connection-:XX:XX:XX:XX:XX:XX/...**

Use this item to get driver information and configure Intel(R) I211 gigabit network connections.

▶ **Intel(R) I211 Gigabit Network Connection-:XX:XX:XX:XX:XX:XX/...**

Use this item to get driver information and configure Intel(R) I211 gigabit network connections.

▶ **Intel(R) I211 Gigabit Network Connection-:XX:XX:XX:XX:XX:XX/...**

Use this item to get driver information and configure Intel(R) I211 gigabit network connections.

▶ **Intel(R) I211 Gigabit Network Connection-:XX:XX:XX:XX:XX:XX/...**

Use this item to get driver information and configure Intel(R) I211 gigabit network connections.

▶ **Intel(R) I211 Gigabit Network Connection-:XX:XX:XX:XX:XX:XX/...**

Use this item to get driver information and configure Intel(R) I211 gigabit network connections.

3-8 Chipset Menu

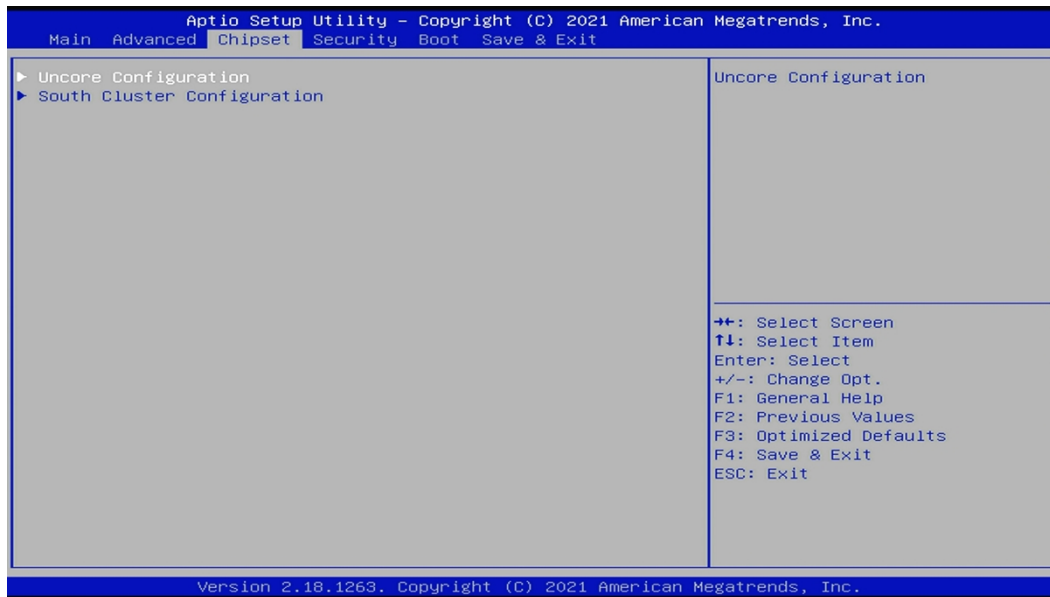

▶ **Uncore Configuration**

Press [Enter] to make settings for the following sub-items:

GTT Size

The optional settings are: [2MB]; [4MB]; [8MB].

DVMT Pre-Allocated

Use this item to select DVMT 5.0 pre-allocated (fixed) graphics memory size used by the internal graphics device.

The optional settings are: [64M]; [96M]; [128M]; [160M]; [192M]; [224M]; [256M]; [288M]; [320M]; [352M]; [384M]; [416M]; [448M]; [480M]; [512M].

DVMT Total Gfx Mem

Use this item to select DVMT 5.0 total graphics memory size used by the internal graphics device.

The optional settings are: [256M]; [128M]; [MAX].

Memory Configuration

The working memory information will be on display.

▶ **South Cluster Configuration**

▶ **PCI Express Configuration**

Press [Enter] to make settings for PCI Express Configuration Settings:

PCI Express Configuration

Peer Memory Write Enable

Use this item to enable or disable Peer memory write.

The optional settings are: [Disabled]; [Enabled].

Compliance Mode

Use this item to enable or disable Compliance Mode.

The optional settings are: [Disabled]; [Enabled].

**Note: The optional settings for the following sub-items are only for NF692S6-345B1.*

LAN3&4 Bypass State @ PowerOn

Use this item to set bypass state at power on.

The optional settings are: [Bypass]; [Passthrough].

LAN3&4 Bypass State @ PowerOff

Use this item to set bypass state at power off.

The optional settings are: [Bypass]; [Passthrough].

**Note: The optional settings for the following sub-items are only for NF692S6-345B2.*

LAN5&6 Bypass State @ PowerOn

Use this item to set bypass state at power on.

The optional settings are: [Bypass]; [Passthrough].

LAN5&6 Bypass State @ PowerOff

Use this item to set bypass state at power off.

The optional settings are: [Bypass]; [Passthrough].

▶ **SATA Configuration**

Press [Enter] to make settings for the following sub-items:

SATA Controller(s)

Use this item to enable or disable the chipset SATA controller. The chipset SATA controller supports the 2 black internal SATA ports (up to 3Gb/s supported per port).

The optional settings are: [Enabled]; [Disabled].

When set as [Enabled], users can make more settings for the following sub-items:

SATA Mode Selection

This item determines SATA controller(s) operation.
The default setting is: [AHCI].

SATA Port

SATA Port

Use this item to enable or disable SATA port.
The optional settings are: [Disabled]; [Enabled].

mSATA

mSATA

Use this item to enable or disable mSATA port.
The optional settings are: [Disabled]; [Enabled].

SCC eMMC Support

Use this item to enable or disable SCC eMMC Support.
The optional settings are: [Disabled]; [Enabled]

When set as [Enabled], the following item shall appears:

eMMC Max Speed

Use this item to select the eMMC max speed allowed.
The optional settings are: [HS400]; [HS200]; [DDR50].

System State after Power Failure

Use this item to select AC power state when power is re-applied after a power failure.

The optional settings are: [Always On]; [Always Off]; [Former State].

** The option [Always On] and [Former State] are affected by ERP function. Please disable ERP to support [Always On] and [Former State] function.*

3-9 Security Menu

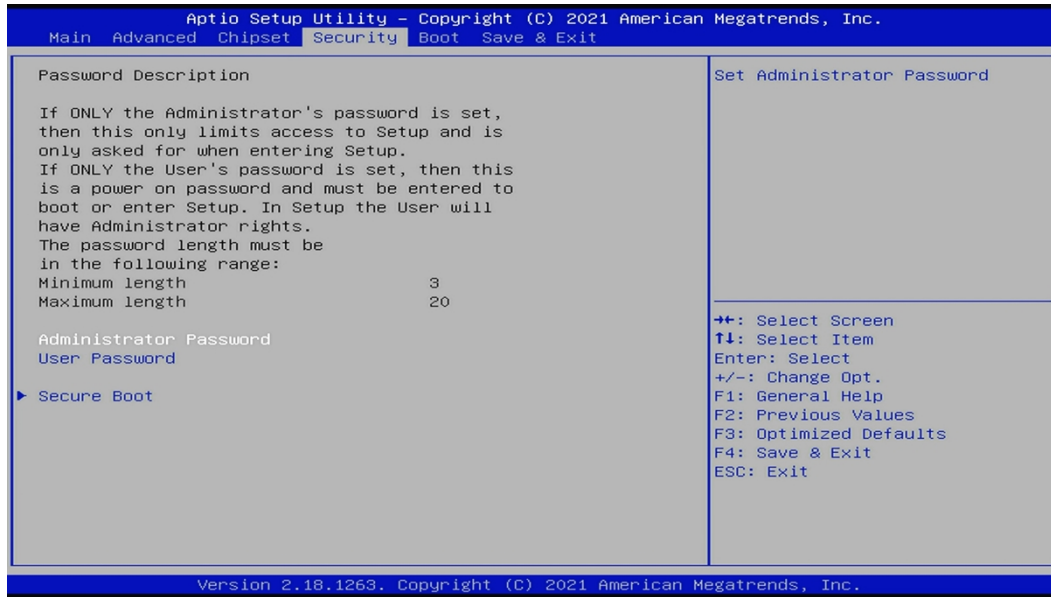

Security menu allow users to change administrator password and user password settings.

Administrator Password

If there is no password present on system, please press [Enter] to create new administrator password. If password is present on system, please press [Enter] to verify old password then to clear/change password. Press again to confirm the new administrator password.

User Password

If there is no password present on system, please press [Enter] to create new administrator password. If password is present on system, please press [Enter] to verify old password then to clear/change password. Press again to confirm the new administrator password.

▶ Secure Boot

Press [Enter] to make customized secure settings:

Secure Boot Control

Secure Boot can be enabled if 1. System running in user mode with enrolled

Platform Key (PK); 2. CSM function is disabled.
The optional settings are: [Disabled]; [Enabled].

Secure Boot Mode

Set UEFI Secure Boot Mode to Standard mode or Custom mode. This change is effective after save. After reset, this mode will return to Standard mode.

The optional settings are: [Standard]; [Custom].

**When set as [Custom], user can make further settings in 'Key Management'.*

▶ **Key Management**

This item enables experienced users to modify Secure Boot variables, which includes the following items:

Provision Factory Default Keys

This item is for user to install factory default secure boot keys when system is in Setup Mode.

The optional settings are: [Disabled]; [Enabled].

▶ **Enroll all Factory Default Keys**

This item forces system to User Mode-install all Factory Default keys.

▶ **Save all Secure Boot Variables**

This item will save all secure boot variables made by user.

▶ **Platform Key (PK)/Key Exchange Keys/Authorized Signature/Forbidden Signature/ Authorized TimeStamps/OS Recovery Signatures**

Use this item to enroll Factory Defaults or load the keys from a file with:

1. Public Key Certificate in:

- a) EFI_SIGNATURE_LIST
- b) EFI_CERT_X509 (DER encoded)
- c) EFI_CERT_RSA2048 (bin)
- d) EFI_CERT_SHA256 (bin)

2. Authenticated UEFI Variable

3-10 Boot Menu



Setup Prompt Timeout

Use this item to set number of seconds to wait for setup activation key.

Bootup Numlock State

Use this item to select keyboard numlock state.

The optional settings are: [On]; [Off].

Quiet Boot

Use this item to enable or disable Quit Boot option.

The optional settings are: [Disabled]; [Enabled].

Boot Option Priorities

Boot Option #1

Use this item to set the system boot order.

The optional settings are: [UEFI: Built-in EFI Shell]; [Disabled].

3-11 Save & Exit Menu

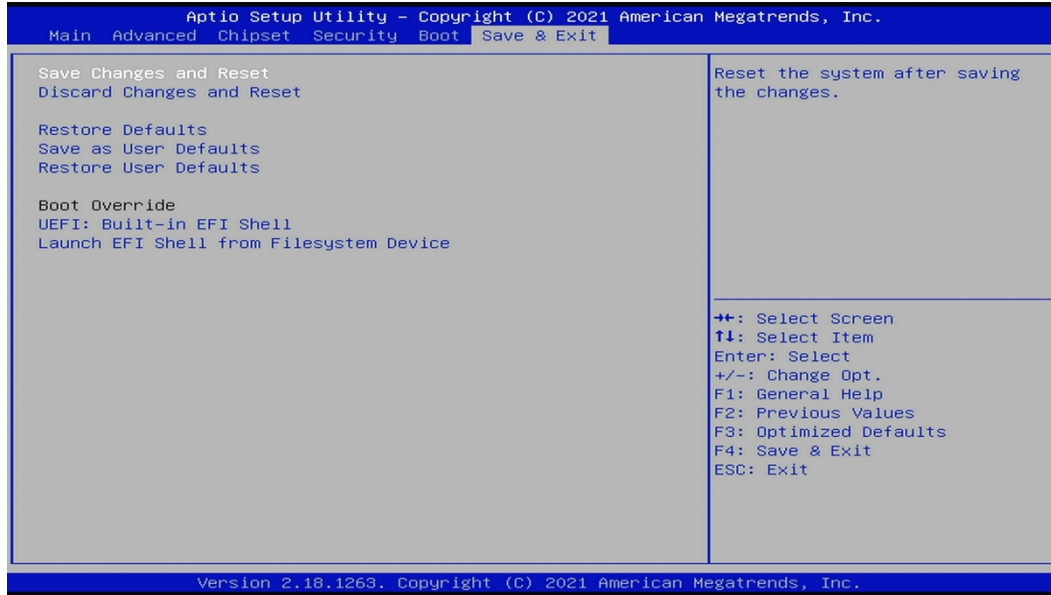

Save Changes and Reset

This item allows user to reset the system after saving the changes.

Discard Changes and Reset

This item allows user to reset the system without saving any changes.

Restore Defaults

Use this item to restore /load default values for all the setup options.

Save as User Defaults

Use this item to save the changes done so far as user defaults.

Restore User Defaults

Use this item to restore defaults to all the setup options.

Boot Override

The available options here are dynamically updated and make system boot to any boot option selected.

UEFI: Built-in EFI Shell

Launch EFI Shell from filesystem device

Use this item to launch EFI shell application (Shell.efi) from one of the available

filesystem devices.