

***TECHNICAL MANUAL***  
***Of***  
***Intel Pine Trail-D & ICH8M Chipset***  
***Based***  
***Mini-ITX M/B***

**NO.G03-NF9H-F**

**Revision: 2.0**

**Release date: May 14th, 2013**

**Trademark:**

- \* Specifications and Information contained in this documentation are furnished for information use only, and are subject to change at any time without notice, and should not be construed as a commitment by manufacturer.

# Environmental Protection Announcement

Do not dispose this electronic device into the trash while discarding. To minimize pollution and ensure environment protection of mother earth, please recycle.



# **TABLE OF CONTENT**

ENVIRONMENTAL SAFETY INSTRUCTION.....	iii
USER'S NOTICE .....	iv
MANUAL REVISION INFORMATION.....	iv
ITEM CHECKLIST .....	iv
<b>CHAPTER 1 INTRODUCTION OF THE MOTHERBOARD</b>	
1-1 FEATURE OF MOTHERBOARD.....	1
1-2 SPECIFICATION .....	2
1-3 LAYOUT DIAGRAM.....	3
<b>CHAPTER 2 HARDWARE INSTALLATION</b>	
2-1 JUMPER SETTING .....	7
2-2 CONNECTORS AND HEADERS.....	10
2-2-1 CONNECTORS .....	10
2-2-2 HEADERS .....	13
<b>CHAPTER 3 INTRODUCING BIOS</b>	
3-1 ENTERNING SETUP.....	19
3-2 GETTING HELP .....	19
3-3 THE MAIN MENU.....	19
3-4 STANDARD BIOS FEATURES .....	21
3-5 ADVANCED BIOS FEATURES .....	23
3-5-1 CPU FEATURE .....	25
3-6 ADVANCED CHIPSET FEATURES .....	25
3-7 INTEGRATED PHERIPHRALS .....	27
3-7-1 ONBOARD SATA FUNCTION .....	28
3-7-2 ONBOARD DEVICE FUNCTION.....	29
3-7-3 ONBOARD SUPER IO FUNCTION.....	30
3-8 POWER MANAGEMENT SETUP.....	31
3-9 PNP/PCI CONFIGURATIONS.....	33
3-10 PC HEALTH STATUS.....	34
3-11 MISCELLANEOUS CONTROL.....	36
3-12 PASSWORD SETTING .....	37
3-13 LOAD OPTIMIZED /STANDARDDEFAULTS .....	38
3-14 SAVE AND EXIT SETUP/EXIT WITHOUT SAVING .....	39



## Environmental Safety Instruction

---

- Avoid the dusty, humidity and temperature extremes. Do not place the product in any area where it may become wet.
- 0 to 60 centigrade is the suitable temperature. (The figure comes from the request of the main chipset)
- Generally speaking, dramatic changes in temperature may lead to contact malfunction and crackles due to constant thermal expansion and contraction from the welding spots' that connect components and PCB. Computer should go through an adaptive phase before it boots when it is moved from a cold environment to a warmer one to avoid condensation phenomenon. These water drops attached on PCB or the surface of the components can bring about phenomena as minor as computer instability resulted from corrosion and oxidation from components and PCB or as major as short circuit that can burn the components. Suggest starting the computer until the temperature goes up.
- The increasing temperature of the capacitor may decrease the life of computer. Using the close case may decrease the life of other device because the higher temperature in the inner of the case.
- Attention to the heat sink when you over-clocking. The higher temperature may decrease the life of the device and burned the capacitor.

## USER'S NOTICE

COPYRIGHT OF THIS MANUAL BELONGS TO THE MANUFACTURER. NO PART OF THIS MANUAL, INCLUDING THE PRODUCTS AND SOFTWARE DESCRIBED IN IT MAY BE REPRODUCED, TRANSMITTED OR TRANSLATED INTO ANY LANGUAGE IN ANY FORM OR BY ANY MEANS WITHOUT WRITTEN PERMISSION OF THE MANUFACTURER.

THIS MANUAL CONTAINS ALL INFORMATION REQUIRED TO USE THIS MOTHER-BOARD SERIES AND WE DO ASSURE THIS MANUAL MEETS USER'S REQUIREMENT BUT WILL CHANGE, CORRECT ANY TIME WITHOUT NOTICE. MANUFACTURER PROVIDES THIS MANUAL "AS IS" WITHOUT WARRANTY OF ANY KIND, AND WILL NOT BE LIABLE FOR ANY INDIRECT, SPECIAL, INCIDENTAL OR CONSEQUENTIAL DAMAGES (INCLUDING DAMAGES FOR LOSS OF PROFIT, LOSS OF BUSINESS, LOSS OF USE OF DATA, INTERRUPTION OF BUSINESS AND THE LIKE).

PRODUCTS AND CORPORATE NAMES APPEARING IN THIS MANUAL MAY OR MAY NOT BE REGISTERED TRADEMARKS OR COPYRIGHTS OF THEIR RESPECTIVE COMPANIES, AND THEY ARE USED ONLY FOR IDENTIFICATION OR EXPLANATION AND TO THE OWNER'S BENEFIT, WITHOUT INTENT TO INFRINGE.

## Manual Revision Information

Reversion	Revision History	Date
2.0	Second Edition	May 14 <sup>th</sup> , 2013

## Item Checklist

- Motherboard
- Motherboard User's Manual
- DVD for motherboard utilities
- Cable(s)
- I/O Back panel shield

# Chapter 1

## Introduction of the Motherboard

### 1-1 Feature of Motherboard

- Intel Pine Trail-D and ICH8M chipset.
- Onboard Intel Atom dual core CPU, with low power consumption never denies high performance.
- Support 2 \* DDRIII 800MHz Single CH SO-DIMM up to 4GB
- Support PCI Express x1 slot and MINI-PCIE slot
- Onboard 4 \* RJ-45 gigabit Ethernet LAN ports
- Integrated with 18-bit single channel LVDS
- Support USB 2.0 data transport demands
- Support 2\* SATAII ports
- Supports ACPI S3 Function
- Compliance with EuP Standard
- Support CPU Smart FAN
- Support Watchdog Technology

## 1-2 Specification

Spec	Description
<b>Design</b>	<ul style="list-style-type: none"> <li>● Mini-ITX form factor; PCB size: 17.0x17.0cm</li> </ul>
<b>Chipset</b>	<ul style="list-style-type: none"> <li>● Intel Pine Trail-D+ICH8M Chipset</li> </ul>
<b>Embedded CPU</b>	<ul style="list-style-type: none"> <li>● ATOM CPU</li> </ul>
<b>Memory Socket</b>	<ul style="list-style-type: none"> <li>● DDRIII SODIMM slot x2</li> <li>● Support two un-buffered Single Channel DDRIII 800 MHz SO-DIMM with memory capacity expandable to 4GB</li> </ul>
<b>Expansion Slot</b>	<ul style="list-style-type: none"> <li>● 1 pcs of PCI Express x1 slot</li> <li>● 1 pcs of full-size Mini-PCIE /Mini-SATA slot</li> <li>● 1 pcs of CF card slot</li> </ul>
<b>LAN Chip</b>	<ul style="list-style-type: none"> <li>● Integrated with four Realtek RTL8111EVL PCI-E Gigabit LAN chips</li> <li>● Support Fast Ethernet LAN function of providing 10/100/1000Mbps Ethernet data transfer rate</li> </ul>
<b>BIOS</b>	<ul style="list-style-type: none"> <li>● AMI 8MB DIP Flash ROM</li> </ul>
<b>Multi I/O</b>	<ul style="list-style-type: none"> <li>● Serial port connector x1</li> <li>● USB 2.0 port connector x2</li> <li>● RJ-45 LAN connector x4</li> <li>● SATAII Connector x2</li> <li>● Serial port header x1</li> <li>● USB 2.0 header x2 (support four expansion USB 2.0 ports)</li> <li>● Front panel header x1</li> <li>● 3-pin Power LED header x1</li> <li>● Speaker header x1</li> <li>● LANLED header x1</li> <li>● VGA header x1</li> <li>● GPIO header x1</li> <li>● LVDS header x1</li> <li>● LVDS Inverter x1</li> </ul>

# 1-3 Layout Diagram

## Rear IO Diagram

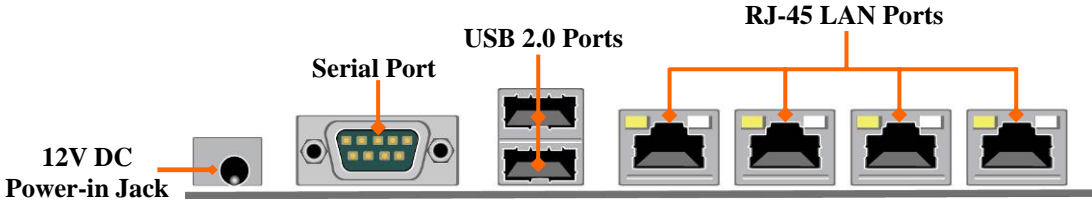



# Motherboard Internal Diagram

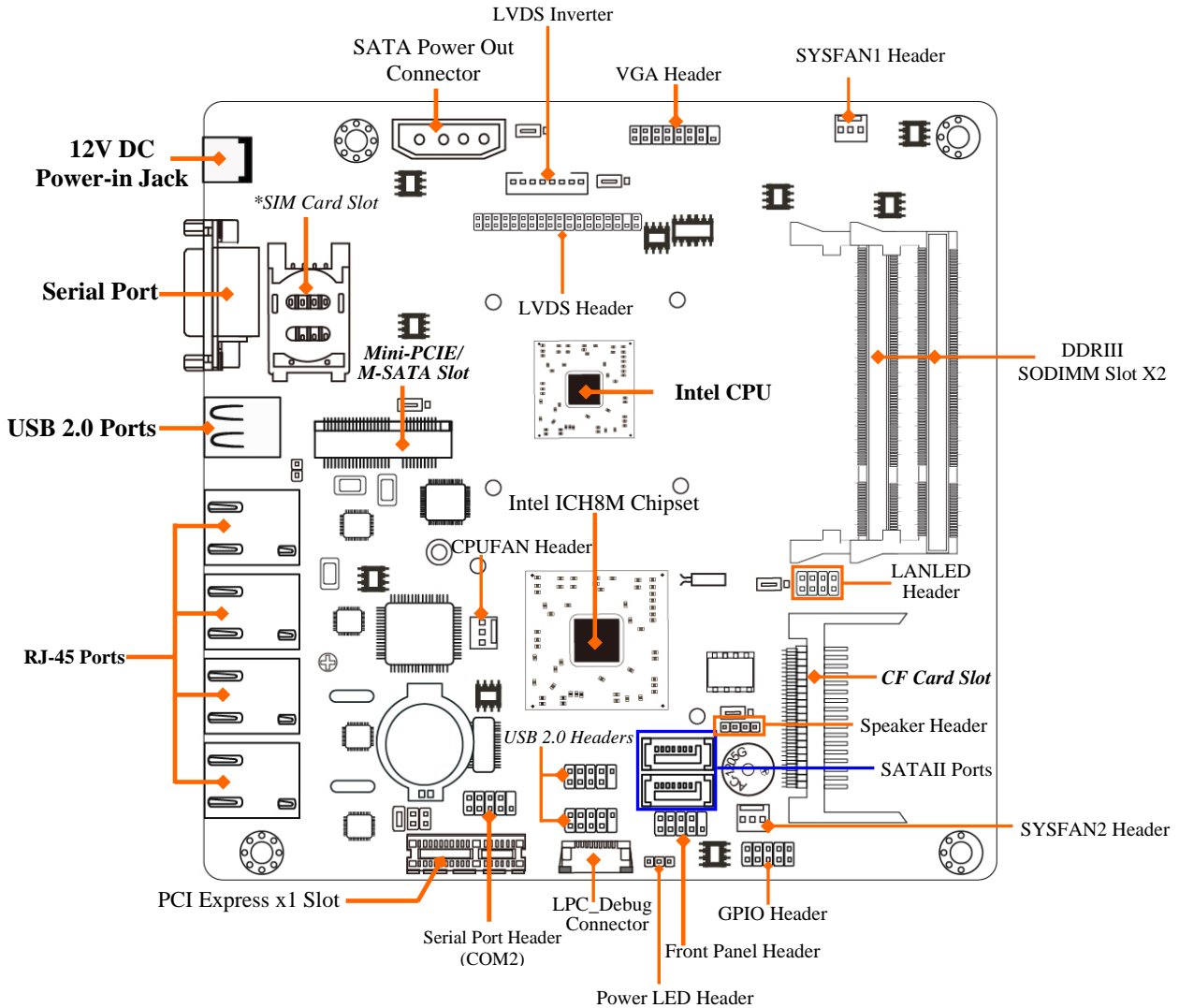

**\*Note:** SIM card slot is optional, depending on the model you purchase.

# Motherboard Jumper Position

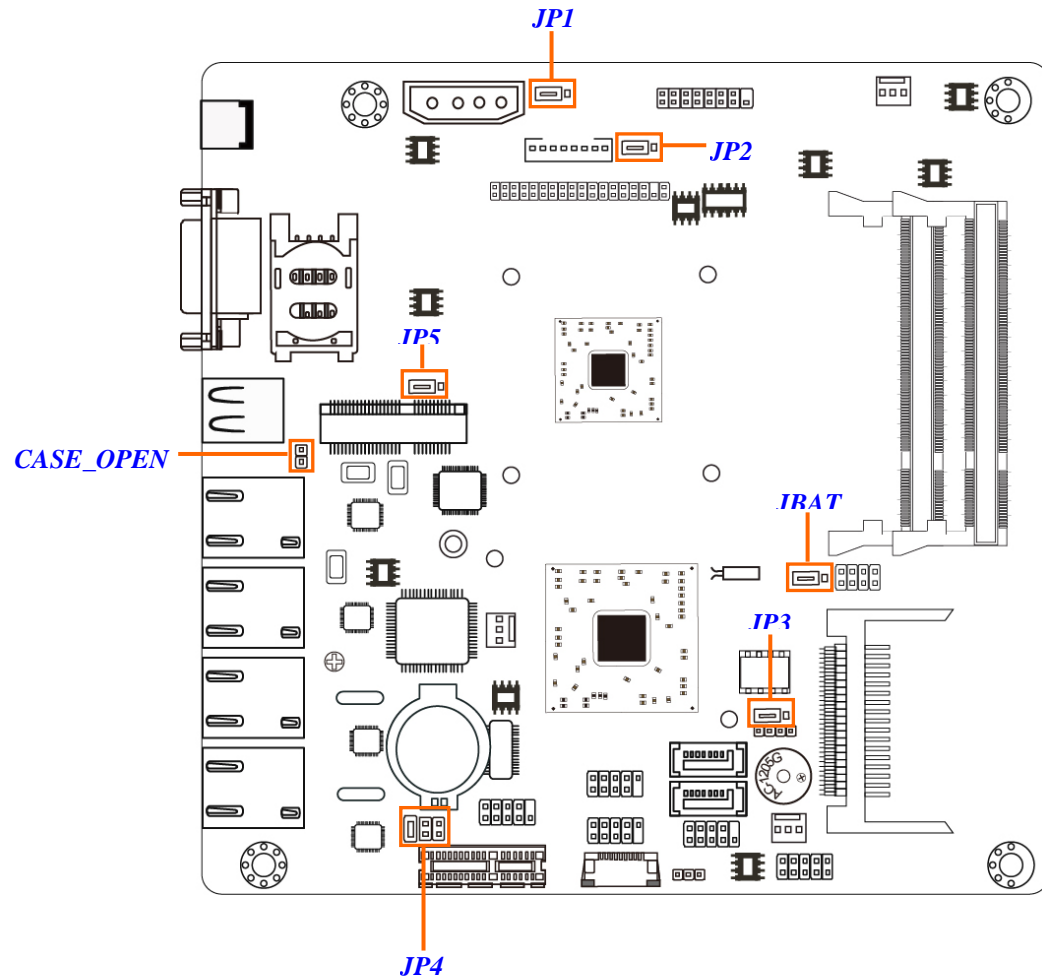

## ***Jumper***

<b>Jumper</b>	<b>Name</b>	<b>Description</b>
JBAT	CMOS RAM Clear Function Setting	3-pin Block
JP1	Inverter12V/5V Select	3-pin Block
JP2	LVDS PVCC 5V/3.3V Select	3-pin Block
JP3	CF Card Mode Select	3-pin Block
JP4	COM2 Pin9 Function Select	6-pin Block
JP5	Mini PCI-E Power VCC3.3V /3VSB Select	3-Pin Block
CASE_OPEN	Case Open Message Display Function	2-pin Block

## ***Connectors***

<b>Connector</b>	<b>Name</b>
J1	DC 12V Power –in Connector
COM1	Serial Port COM Connector
USB1	USB 2.0 Port Connectors
LAN1/2/3/4	RJ-45 LAN Connectors
PWOUT	SATA Power out Connector
SATA1/2	SATAII Connector
INVERTER	LVDS Inverter Connector
CPUFAN1,SYSFAN1/2	FAN Headers

## ***Headers***

<b>Header</b>	<b>Name</b>	<b>Description</b>
COM2	Serial Port Header	9-pin Block
USB2/3	USB 2.0 Header	9-pin Block
JW_FP1	Front Panel Header(PWR LED/ HD LED /Power Button /Reset)	9-pin Block
PWR LED	Power LED	3-pin Block
SPEAK	Speaker Header	4-pin Block
GPIO	GPIO Header	10-pin Block
LANLED	LANLED Header	8-pin Block
LVDS	LVDS Header	35-pin Block
VGA	VGA Header	15-pin Block

# Chapter 2 Hardware Installation

## 2-1 Jumper Setting

### (1) JBAT (3-pin): Clear CMOS

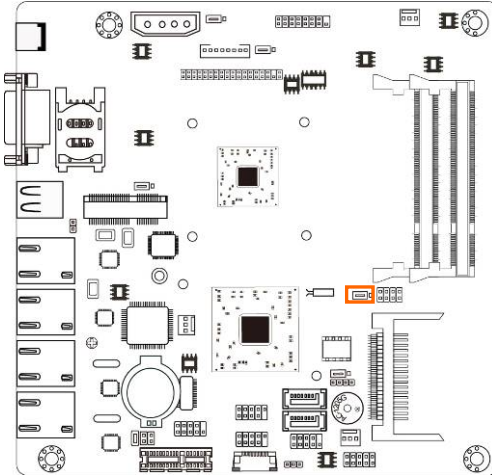

JBAT

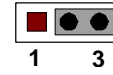
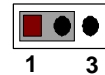

1-2 Closed: Normal; 2-3 Closed: Clear CMOS

CMOS Clear Setting

### (2) JP1 (3-pin): Inverter 5V/12V Select

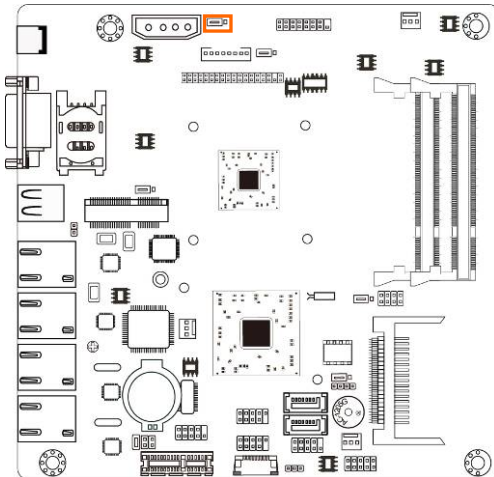

JP1



1-2 Closed: Inverter 12V Selected; 2-3 Closed: Inverter 5V Select

### (3) JP2 (3-pin): LVDS PVCC 5V / 3.3V Select

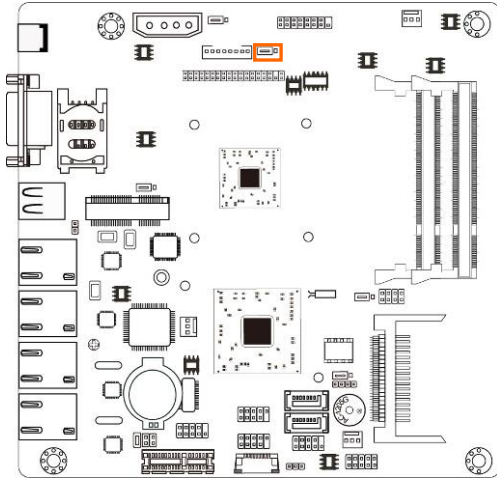

JP2



JP2



1-2 closed: LVDS PVCC= 5V;    2-3 closed : LVDS PVCC= 3.3V

### (4) JP3 (3-pin): CF Card Master /Slave Mode Select

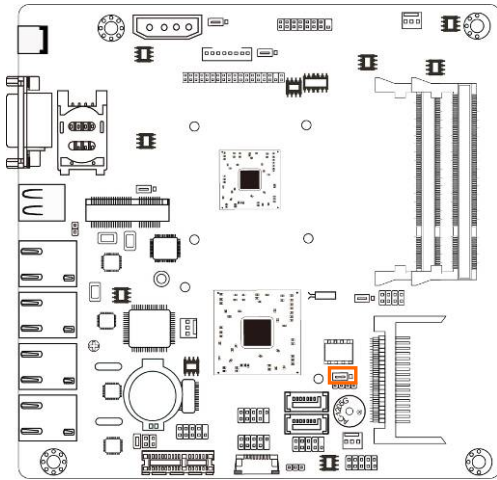

JP3

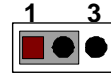

1-2 Closed: CF Card Slave Mode;

JP3

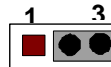

2-3 Closed: CF Card Master Mode;

### (5) JP4 (6-pin): COM2 Pin9 Function Select

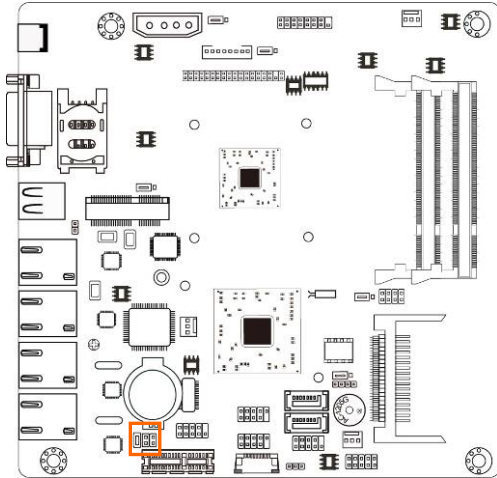

JP4



1



1



1

1-2 closed: RS232; 3-4 closed : +12V; 5-6 closed : +5V

### (6) JP5 (3-pin): Mini PCI-E Power VCC3.3V/ 3VSB Function Select

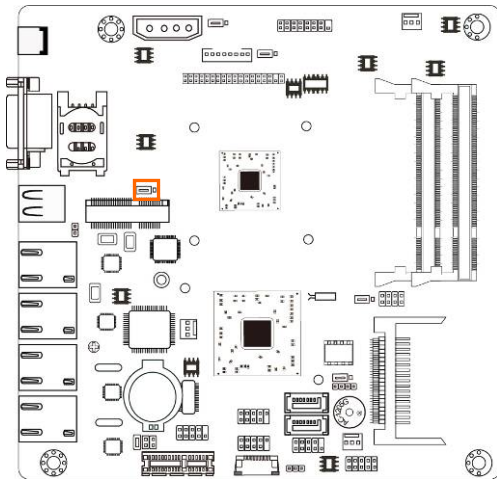

JP5

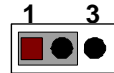

1-2 Closed: MINI PCI-E VCC= 3.3V;

JP5

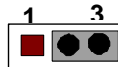

2-3 Closed: MINI PCI-E VCC=3VSB

## (7)CASE\_OPEN(2-pin): Case Open Message Display Function Select

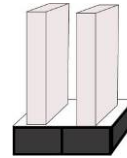
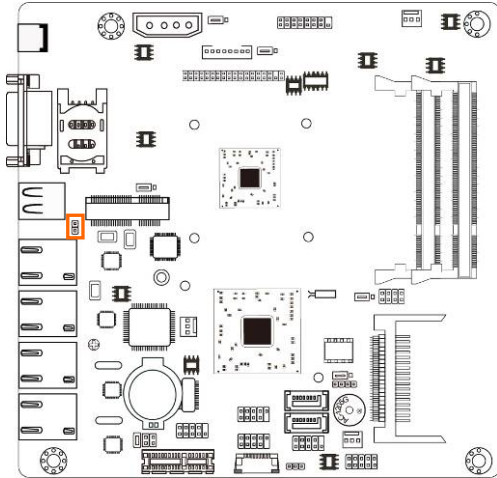

*Pin 1-2 shorted: Case open display function enabled. Use needs to enter BIOS and enable 'Case Open Detect' function. In this case if you case is removed, next time when you restart your computer a message will be displayed onscreen to inform you of this.*

## 2-2 Connectors and Headers

### 2-2-1 Connectors

(1) I/O Panel Connector:

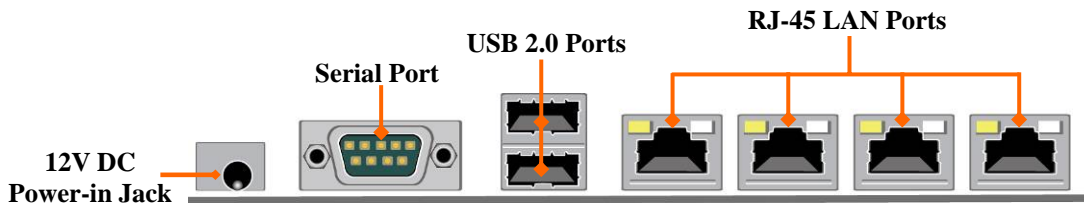

## (2) PWOUT (4-pin): SATA Power Out Connector

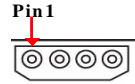
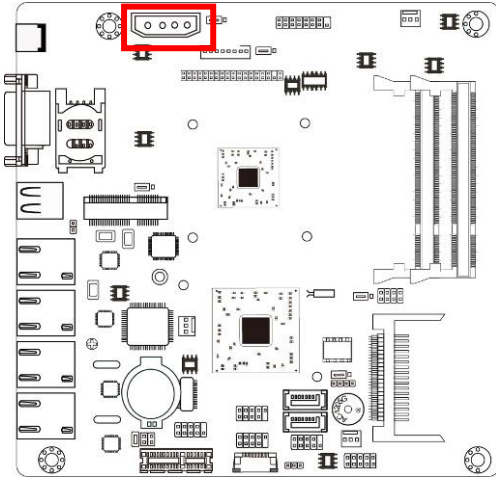

Pin No.	Definition
1	+12V
2	GND
3	GND
4	VCC

## (3) SATA1/SATA2(7-pin): SATA II Port Connector

These connectors are high-speed SATAII ports that support 3 GB/s transfer rate.

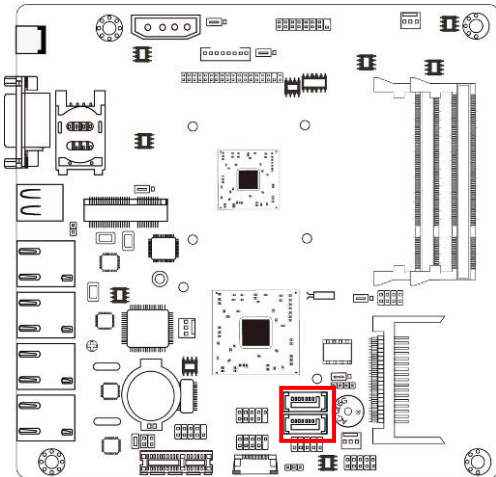

Pin No.	Definition
1	GND
2	TXP
3	TXN
4	GND
5	RXN
6	RXP
7	GND

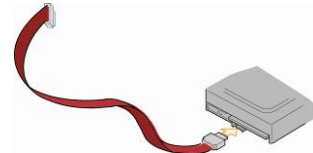



#### (4) INVERTER (8-pin): LVDS Inverter Connector

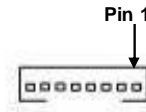
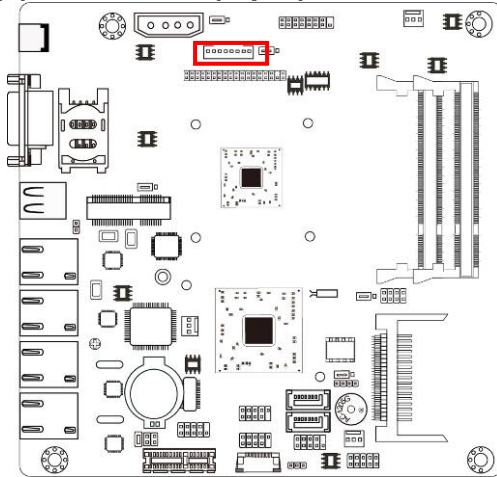

Pin No.	Definition
1	Backlight Enable
2	Backlight Duty
3	PVCC
4	PVCC
5	GND
6	GND
7	NC
8	NC

#### (5) CPUFAN, SYSFAN1, SYSFAN2 (3-pin): FAN Speed Headers

Pin1: GND

Pin2: +12V fan power

Pin3: Fan Speed

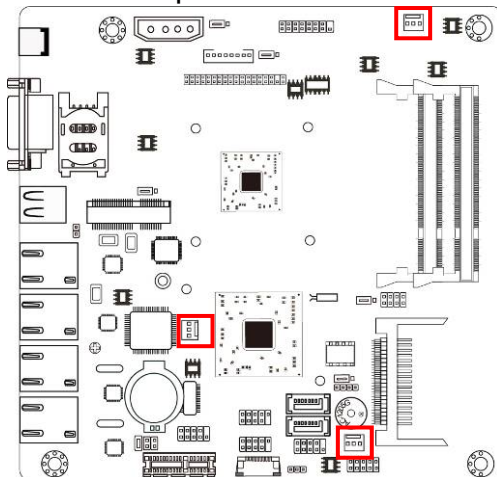

SYSFAN1/SYSFAN2



CPUFAN



## 2-2-2 Headers

### (1) COM2 (9-Pin): Serial Port Header

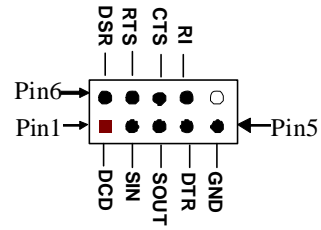
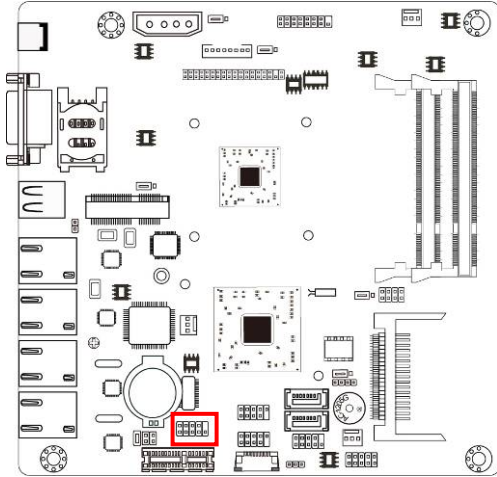

Serial Port Header

### (2) USB2/USB3 (9-pin): USB 2.0 Port Header

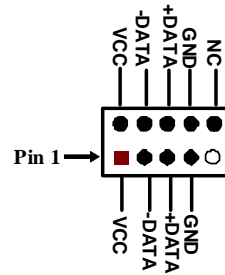
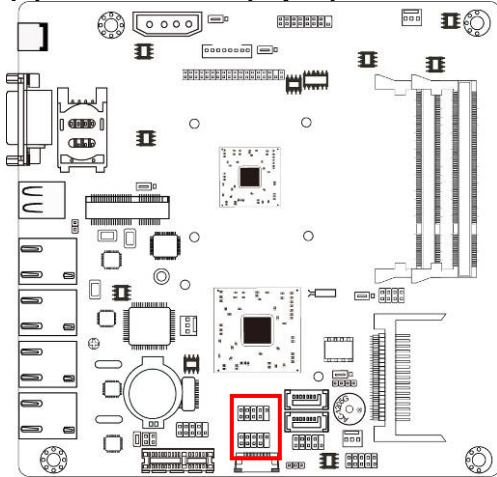

### (3) JW-FP (9-pin): Front Panel Header

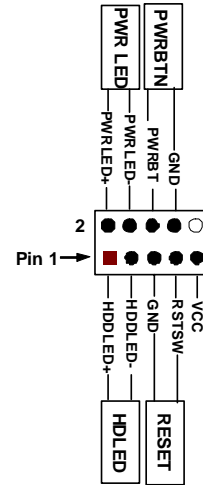
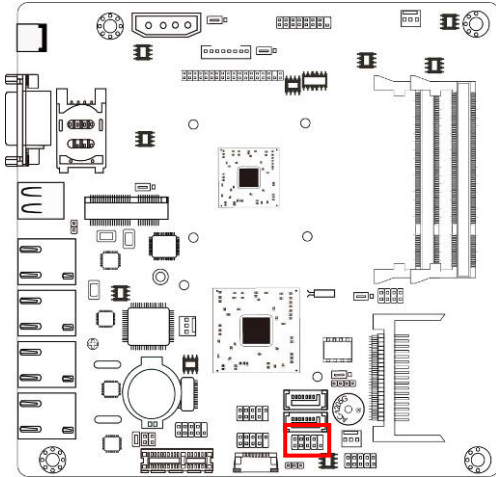

### (4) PWR LED (3-pin): PWR LED Header

The Power LED is light on while the system power is on. Connect the Power LED from the system case to this pin header.

### (5) SPEAK (4-pin): Speaker Header

This 4-pin header connects to the case-mounted speaker. See the figure below.

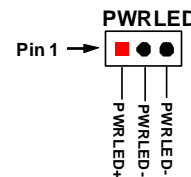
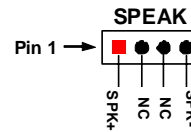
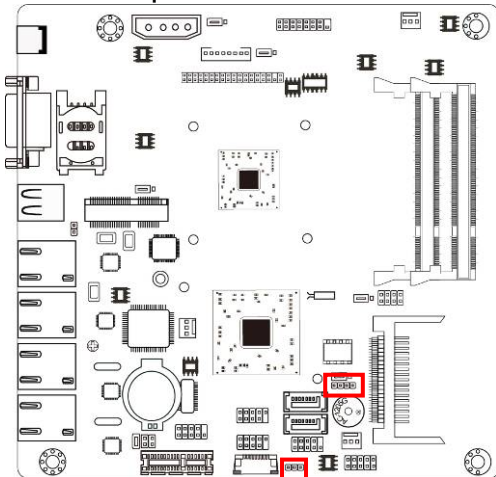

## (6) GPIO (10-pin): GPIO Header

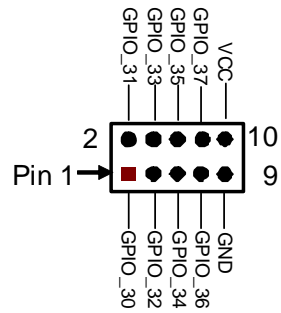
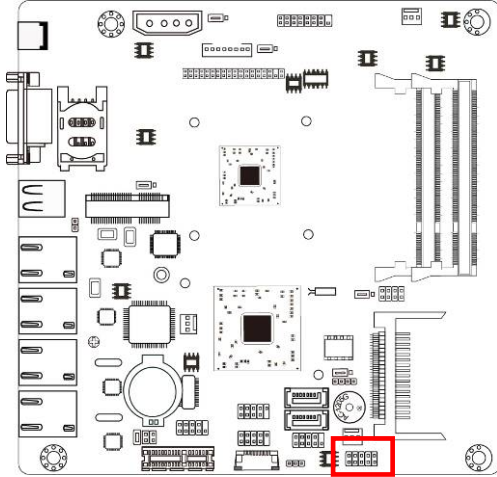

## (7) LANLED (8-pin): LANLED Header

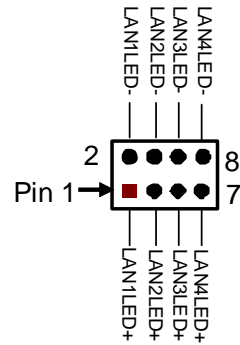
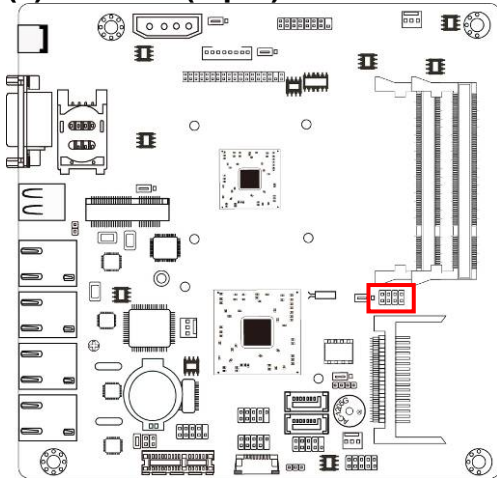

## (8) LVDS (35-pin): 18-bit single channel LVDS Header

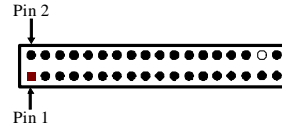
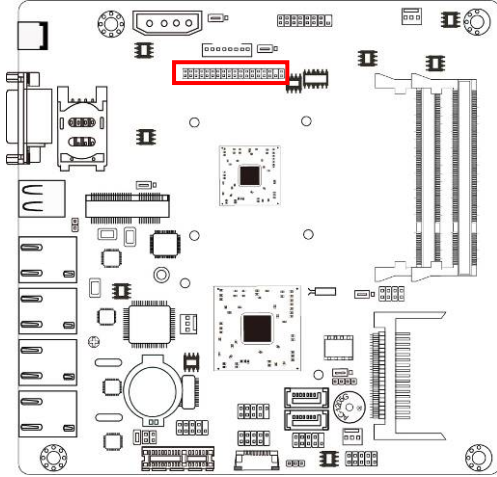

Pin NO.	Pin Define	Pin NO.	Pin Define
Pin 1	NC	Pin 2	NC
Pin 3	NC	Pin 4	NC
Pin 5	NC	Pin 6	NC
Pin 7	NC	Pin 8	NC
Pin 9	NC	Pin 10	NC
Pin 11	LVDS_DDC_DATA	Pin 12	LVDS_DDC_CLK
Pin 13	GND	Pin 14	GND
Pin 15	GND	Pin 16	GND
Pin 17	NC	Pin 18	NC
Pin 19	LVDS_CLKAP	Pin 20	LVDS_CLKAN
Pin 21	LVDSA_DATAP2	Pin 22	LVDSA_DATAN2
Pin 23	LVDSA_DATAP1	Pin 24	LVDSA_DATAN1
Pin 25	LVDSA_DATAP0	Pin 26	LVDSA_DATAN0
Pin 27	PVDD	Pin 28	PVDD
Pin 29	PVDD	Pin 30	PVDD
Pin 31	GND	Pin 32	GND
Pin 33	+5V	Pin 34	N/A
Pin 35	+12V (Reserved)	Pin 36	+3V

### (9) VGA (15-pin): VGA Header

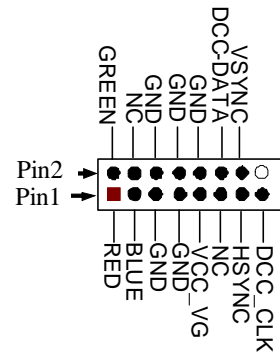
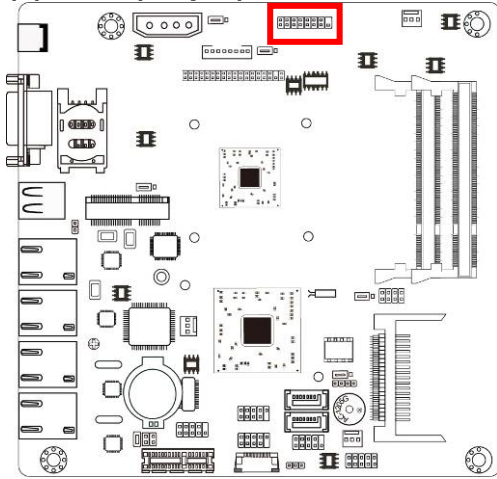

# Chapter 3

## Introducing BIOS

**Notice!** The BIOS options in this manual are for reference only. Different configurations may lead to difference in BIOS screen and BIOS screens in manuals are usually the first BIOS version when the board is released and may be different from your purchased motherboard. Users are welcome to download the latest BIOS version form our official website.

The BIOS is a program located on a Flash Memory on the motherboard. This program is a bridge between motherboard and operating system. When you start the computer, the BIOS program will gain control. The BIOS first operates an auto-diagnostic test called POST (power on self test) for all the necessary hardware, it detects the entire hardware device and configures the parameters of the hardware synchronization. Only when these tasks are completed done it gives up control of the computer to operating system (OS). Since the BIOS is the only channel for hardware and software to communicate, it is the key factor for system stability, and in ensuring that your system performance as its best.

In the BIOS Setup main menu of Figure 3-1, you can see several options. We will explain these options step by step in the following pages of this chapter, but let us first see a short description of the function keys you may use here:

- Press <Esc> to quit the BIOS Setup.
- Press ↑↓←→ (up, down, left, right) to choose, in the main menu, the option you want to confirm or to modify.
- Press <F10> when you have completed the setup of BIOS parameters to save these parameters and to exit the BIOS Setup menu.
- Press +/- keys when you want to modify the BIOS parameters for the active option.

### **3-1 Entering Setup**

Power on the computer and by pressing <Del> immediately allows you to enter Setup. If the message disappears before you respond and you still wish to enter Setup, restart the system to try again by turning it OFF then ON or pressing the "RESET" button on the system case. You may also restart by simultaneously pressing <Ctrl>, <Alt> and <Delete> keys. If you do not press the keys at the correct time and the system does not boot, an error message will be displayed and you will again be asked to

**Press <Del> to enter Setup**

### **3-2 Getting Help**

#### **Main Menu**

The on-line description of the highlighted setup function is displayed at the bottom of the screen.

#### **Status Page Setup Menu/Option Page Setup Menu**

Press F1 to pop up a small help window that describes the appropriate keys to use and the possible selections for the highlighted item. To exit the Help Window, press <Esc>.

### **3-3 The Main Menu**

Once you enter AMI ® BIOS CMOS Setup Utility, the Main Menu (Figure 3-1) will appear on the screen. The Main Menu allows you to select from fourteen setup functions and two exit choices. Use arrow keys to select among the items and press <Enter> to accept or enter the sub-menu.





Figure 3-1

### **Standard BIOS Features**

Use this Menu for basic system configurations.

### **Advanced BIOS Features**

Use this menu to set the Advanced Features available on your system.

### **Advanced Chipset Features**

Use this menu to change the values in the chipset registers and optimize your system's performance.

### **Integrated Peripherals**

Use this menu to specify your settings for integrated peripherals.

### **Power Management Setup**

Use this menu to specify your settings for power management.

### **PnP/PCI Configurations**

Use this menu to specify your settings for PnP and PCI configurations.

**PC Health Status**

This entry shows your PC health status.

**Miscellaneous Control**

Use this menu to specify your settings for Miscellaneous Control.

**Load Optimized Defaults**

Use this menu to load the BIOS default values these are setting for optimal performances system operations for performance use.

**Load Standard Defaults**

Use this menu to load the BIOS default values for the minimal/stable performance system operation

**Set Supervisor Password**

Use this menu to set supervisor password.

**Set User Password**

Use this menu to set user password.

**Save & Exit Setup**

Save CMOS value changes to CMOS and exit setup.

**Exit Without Saving**

Abandon all CMOS value changes and exit setup.

### **3-4 Standard BIOS Features**

The items in Standard CMOS Setup Menu are divided into several categories. Each category includes no, one or more than one setup items. Use the arrow keys to highlight the item and then use the <PgUp> or <PgDn> keys to select the value you want in each item.



### System Date

Use [Enter], [TAB] or [SHIFT+TAB] to select setting field. Then use [+] or [-] to configure system date.

The date format is <day><month><date><year>.

**Day** Day of the week is from Sun to Sat, determined by BIOS. Read-only.

**Month** The month is from Jan. through Dec.

**Date** The date from 1 to 31 can be keyed by numeric function keys.

**Year** The year depends on the year of the BIOS.

### System Time

Use [Enter], [TAB] or [SHIFT+TAB] to select setting field. Then use [+] or [-] to configure system time.

The time format is <hour><minute><second>.

### SATA Channel 1/SATA Channel 2/mSATA/CF Card Master/CF Card Slave

While entering setup, BIOS auto detects the presence of hard disk devices. This displays the status of auto detection of hard disk devices.

**Type:** The optional settings are: [Not Installed]; [Auto]; [CD/DVD] and [ARMD].

**LBA/Large Mode:** The optional settings are [Auto]; [Disabled].

Disabled: disables LBA mode.

Auto: enables LBA Mode if the devices support it and the device is not already formatted with LBA Mode disabled.

**Block (Multi-Sector Transfer):** The optional settings are: [Disabled] and [Auto].

Disabled: The Data transfer from and to the device occurs one sector at a time.

Auto: The Data transfer from and to the device occurs multiple sectors at a time if the device supports it.

**32 Bit Data Transfer:** the optional settings are: [Disabled] and [Enabled].

### 3-5 Advanced BIOS Features

Copyright (C) 1985-2009, American Megatrends, Inc. Advanced BIOS Features		Help Item
Virus Warning	Disabled	
▶ CPU Feature	Press Enter	
Quick Power On Self Test	Enabled	Enable/Disable
Boot Up NumLock Status	Off	Boot Sector Virus
APIC Mode	Enabled	Protection.
MPS Version Control for OS	1.4	

F4: Move Enter: Select +/-: Value F10: Save ESC: Exit F1: General Help  
F5: Previous Values F6: Optimized Defaults F7: Standard Defaults

## **Virus Warning**

The selection Allow you to choose the VIRUS Warning feature for Hard Disk boot sector protection. If this function is enabled and someone attempt to write data into this area, BIOS will show a warning message on screen and alarm beep.

**Disabled** (default) No warning message to appear when anything attempts to access the boot sector or hard disk partition table.

**Enabled** Activates automatically when the system boots up causing a warning message to appear when anything attempts to access the boot sector of hard disk partition table.

## **Quick Power On Self Test**

This item allows BIOS to skip certain tests while booting. This will decrease the time needed to boot the system. The optional settings: [Disabled]; [Enabled].

## **Boot Up NumLock Status**

Use this item to select power-on state for Numlock key.

## **APIC Mode**

Use this item to include ACPI APIC table pointer to ESDT pointer list. The optional settings: [Disabled]; [Enabled].

## **MPS Version Control for OS**

This option is only valid for multiprocessor motherboards as it specifies the version of The Multiprocessor Specification (MPS) that the motherboard will use. The optional settings: [1.1]; [1.4].

## 3-5-1 CPU Feature

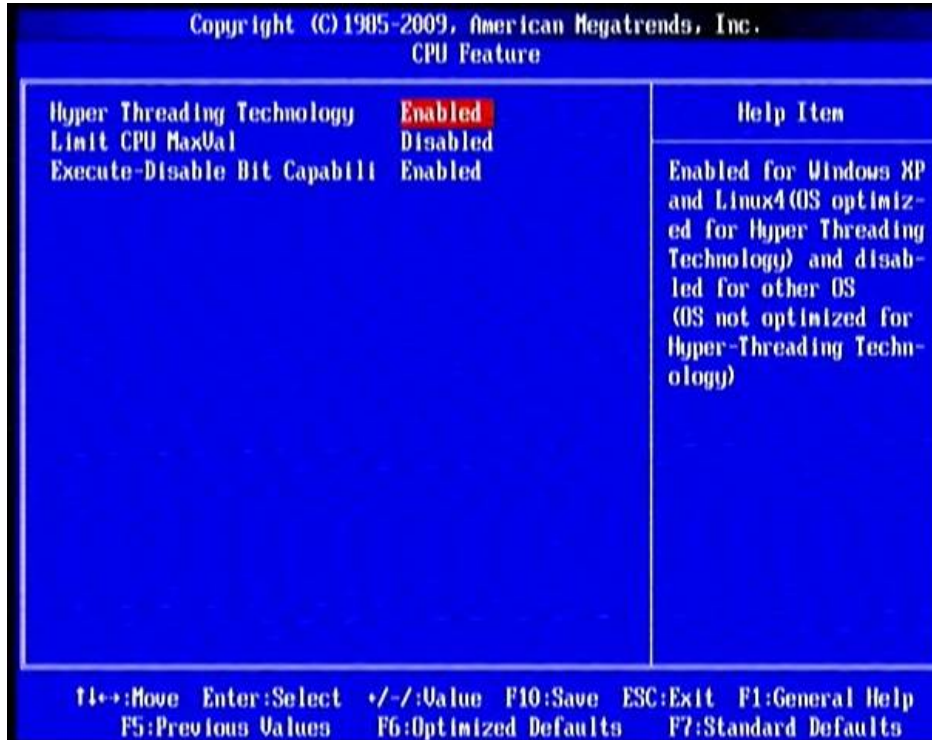

### Hyper Threading Technology

Enabled for Windows XP and Linux4 (OS optimized for Hyper Threading Technology) and disabled for other OS (OS not optimized for Hyper –Threading Technology).

### Limit CPU MaxVal

The optional settings are: [Disabled]; [Enabled].

### Execute Disable Bit Capability

The optional settings are: [Disabled]; [Enabled]. When disabled, force the XD feature Flag to always return 0.

## 3-6 Advanced Chipset Features

The Advanced Chipset Features Setup option is used to change the values of the chipset registers. These registers control most of the system options in the computer.

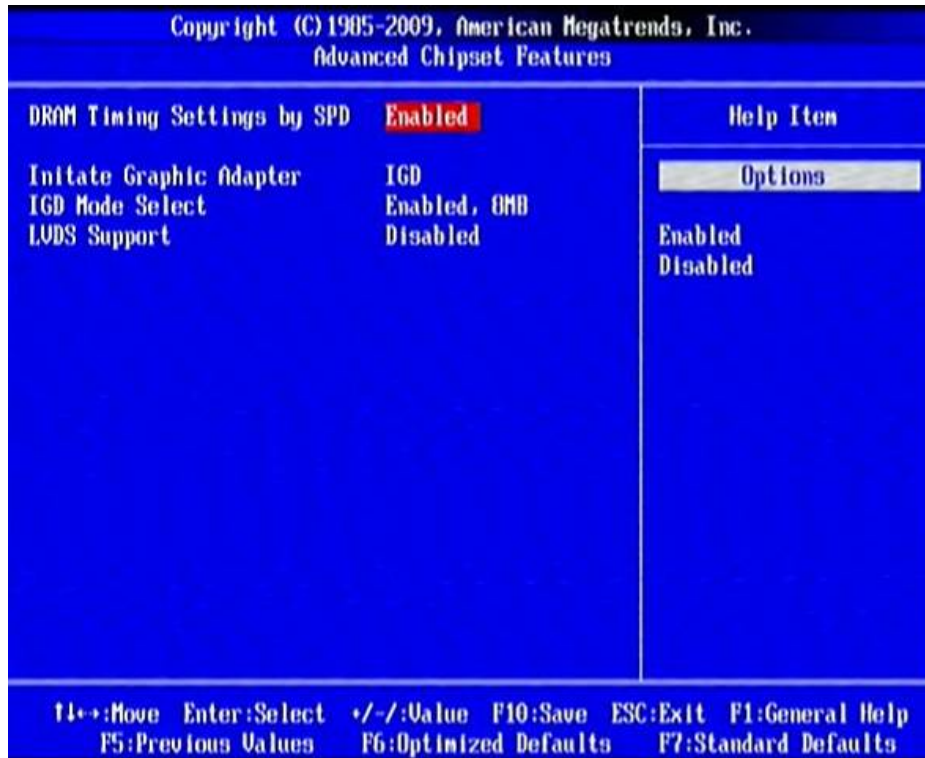

### DRAM Timing Settings by SPD

The optional settings are: [Disabled]; [Enabled].

### Initate Graphic Adapter

The optional settings are: [IGD]; [PCI/IGD]. Select which graphic controller to use as the primary boot device.

### IGD Mode Select

Use this item to select the amount of system memory used by the internal graphics device. The optional settings: [Disabled]; [Enabled, 8MB].

### LVDS Support

The optional settings are: [Enabled]; [Disabled].

***When set as [Enabled], the following setting items will appear:***

### Boot Display Device

The optional settings are: [VBIOS Default]; [CRT]; [LVDS]; [CRT+LVDS].



## Flat Panel Type

Use this item to select flat panel resolution type.

The optional settings are: [640X 480]; [800X 600]; [1024X768]; [800X480]; [1024X600]; [1366X768]; [1280X768]; [1280X800];[1280X600].

## Backlight Control Support

The optional settings are: [VBIOS Default];[Both BLC & BIA Disabled];[BLC Enabled].

## 3-7 Integrated Peripherals





## 3-7-1 Onboard SATA Function

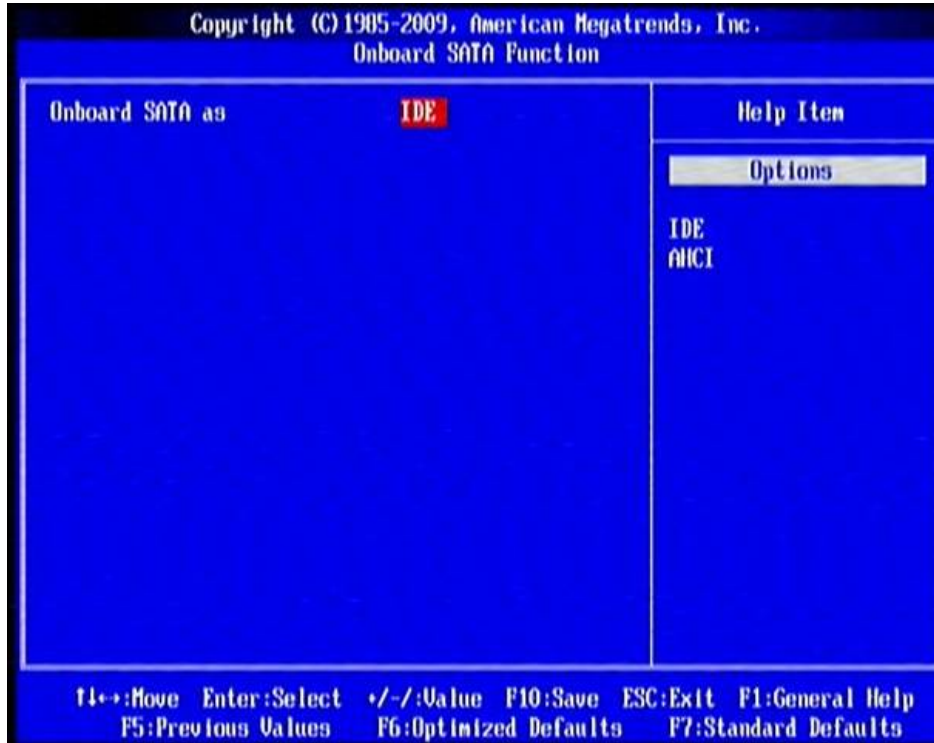

### Configure SATA as

The optional settings are: [IDE]; [AHCI].

## 3-7-2 Onboard Device Function

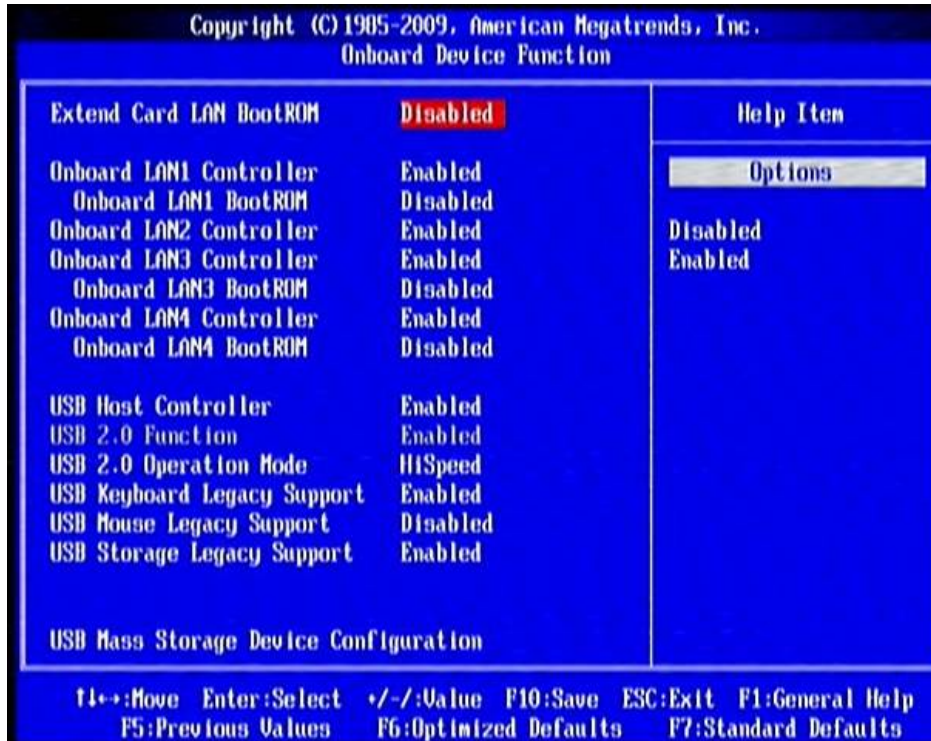

### Extend Card LAN Boot ROM

The optional settings are: [Enabled]; [Disabled].

### Onboard LAN1 Controller/ Onboard LAN2 Controller/Onboard LAN3 Controller/ Onboard LAN4 Controller

The optional settings are: [Enabled]; [Disabled].

### Onboard LAN1BootROM/ Onboard LAN3BootROM/Onboard LAN4BootROM

The optional settings are: [Enabled]; [Disabled].

### USB Host Controller

The optional settings: [Enabled]; [Disabled].

### USB 2.0 Function

The optional settings: [Enabled]; [Disabled].

### USB 2.0 Operation Mode

Use this item to configure the USB 2.0 controller in HiSpeed(480Mbps) or FullSpeed(12Mbps).

The settings are: [FullSpeed]; [HiSpeed].

### USB Keyboard Legacy/Mouse Legacy /Storage Legacy Support

Use these items to enable or disable legacy support for USB keyboard/mouse/ mass storage devices. The optional settings are: [Enabled], [Disabled].

## 3-7-3 Onboard Super IO Function



### Serial Port 1/2 Address

This item allows BIOS to select base addresses for serial port 1/2.

### Select RS232/RS422/RS485

The optional settings are: [RS422];[RS232]; [RS485].

### **Mode Speed Select**

The optional settings are:

[RS232=1Mbps,RS422/485=10Mbps];[RS232/422/485=250Kbps].

### **Watchdog Timer Control**

This item is used to activate the watchdog function. The optional settings are: [Enabled]; [Disabled].

***When set as Enabled, The following sub-items shall appear:***

#### **WatchDog Timer Val**

User can type a number in the range of 4 to 255.

#### **WatchDog Timer Unit**

The optional settings are: [Sec.]; [Min.].

## **3-8 Power Management Setup**

The Power Management Setup allows you to configure your system to most effectively save energy saving while operating in a manner consistent with your own style of computer use.



### Case Open Detect

The optional settings are: [Enabled]; [Disabled].

### ACPI Suspend Type

Users can select the ACPI state used for system suspend. The optional settings are: [S1(POS)]; [S3(STR)].

### Video Power Down Mode

The optional settings: [Disabled]; [Standby]; [Suspend].

### Suspend Time Out

Use this item to select the specified time for system to go into suspend.

### Power Button Mode

Use this item to go into [On/Off] or [Delay 4 Sec] when power button is pressed.

### ERP Function

The optional settings are: [Enabled]; [Disabled]. When set as [Disabled], the following sub-items shall appear:

### PWR Status after PWR Failure

The optional settings: [Always Off]; [Always On]; [Former Status].

### Wake-Up by Ring;

Use this item to enable or disable the function to wake up system from an ACPI sleep state by a wake-up signal from modem that supports this function,.

### Wake-Up by LAN from S3-S5;

When set as [Enabled], system will wake up from S3-S5 by LAN PME.

### Wake Up by USB from S3(S4);

Use this item to enable or disable the USB device wake up function from S3(S4) state.

### Resume On RTC Alarm.

When set as [Enable], the system will automatically resume at a fixed time based on system RTC clock.

## 3-9 PnP/PCI Configurations





## IRQ Resources

Press [Enter] to view IRQ availability.

[Available]: Specified IRQ is available to be used by PCI/PnP devices.

[Reserved]: Specified IRQ is reserved for use by legacy ISA devices.

## 3-10 PC Health Status

This section shows the Status of you CPU, Fan, and Warning for overall system status.

This is only available if there is Hardware Monitor onboard.

Copyright (C) 1985-2009, American Megatrends, Inc. PC Health Status		
Shutdown Temperature	Disabled	Help Item
CPU Thermal-Throttling	Disabled	
▶ Smart FAN Configurations	Press Enter	Options
CPU Temperature	37°C/98°F	Disabled
System Temperature	38°C/100°F	60°C/140°F
		65°C/149°F
CPUFAN Speed	N/A	70°C/158°F
SYSFAN1 Speed	4792 RPM	75°C/167°F
SYSFAN2 Speed	N/A	
Vcore	1.152 V	
NB 1.05V	1.040 V	
5VSB	5.002 V	
VDIMM	1.505 V	
+ 5V	4.972 V	
+ 12V	12.144 V	
Vcc3V	3.296 V	
3VSB	3.296 V	

F1: Move Enter: Select +/-: Value F10: Save ESC: Exit F1: General Help  
F5: Previous Values F6: Optimized Defaults F7: Standard Defaults

### Shutdown Temperature

This item can let users set the Shutdown temperature, when CPU temperature over this setting the system will auto shutdown to protect CPU.

### CPU Thermal Throttling

The optional settings are: [Disabled]; [Enabled].

***When it is set as [Enabled], use can make settings for the following items that show up:***

**CPU Thermal-Throttling Temp.;**

Use can select specific temperature for CPU Thermal Throttling function.

**CPU Thermal-Throttling Duty**

The optional settings are: [87.50%]; [75.00%]; [62.50%]; [50.00%]; [37.50%]; [25.00%]; [12.50%].

**CPU Thermal-Throttling Beep.**

The optional settings are: [Disabled]; [Enabled].

**Smart Fan Configurations**

**CPUFAN / SYSFAN1/ SYSFAN2 Smart Mode**

When set as [Enabled], the following sub-items shall appear:

**CPUFAN / SYSFAN1/ SYSFAN2 Full Speed Temp**

Use this item to set a degree for CPUFAN/SYSFAN1/SYSFAN2. FAN will run at full speed when above this temperature.

**CPUFAN / SYSFAN1/ SYSFAN2 Idle Speed Temp**

Use this item to set a degree for CPUFAN/SYSFAN1/SYSFAN2. FAN will idle speed when below this temperature.

**CPUFAN / SYSFAN1/ SYSFAN2 Idle Speed Duty**

Use this item to set idle speed duty for CPUFAN/SYSFAN1/SYSFAN2.

**CPU Temperature/ System Temperature /CPUFAN Speed / SYSFAN1 Speed /SYSFAN2 Speed/ Vcore/ /NB1.05V/5VSB/VDIMM/ +5V/+12V/Vcc3V/3VSB/VBat**

This will show the CPU/FAN/System voltage chart and FAN Speed, etc.



## 3-11 Miscellaneous Control

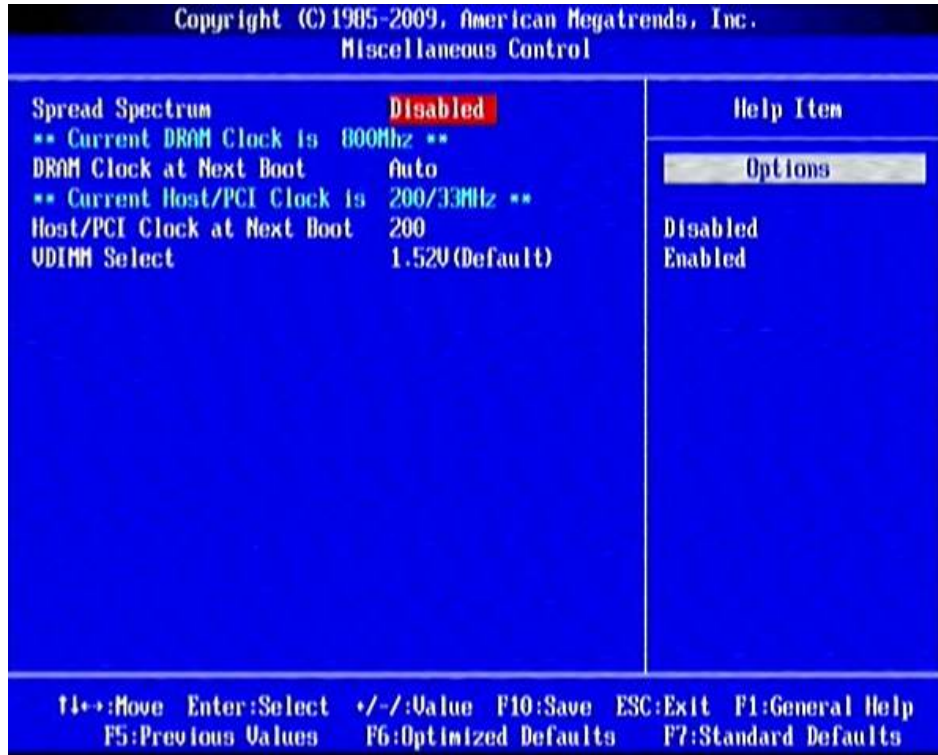

### Spread Spectrum

The optional settings are: [Enabled]; [Disabled].

### DRAM Clock at Next Boot

This item allows you to set DRAM clock. The optional settings are: [Auto]; [667MHz]; [800MHz].

### Host/PCI Clock at Next Boot

The optional settings are from 200 to 300.

### VDIMM Select

The optional settings are: [1.52V (Default)]; [1.55V]; [1.60V]; [1.65V].

## 3-12 Password Setting

You can set either supervisor or user password, or both of them. The differences are:

**Supervisor password:** Can enter and change the options of the setup menus.

**User password:** Can only enter but do not have the right to change the options of the setup menus. When you select this function, the following message will appear at the center of the screen to assist you in creating a password.

### **ENTER PASSWORD:**

Type the password, up to eight characters in length, and press <Enter>. The password typed now will clear any previously entered password from CMOS memory. You will be asked to confirm the password. Type the password again and press <Enter>. You may also press <Esc> to abort the selection and not enter a password. To disable a password, just press <Enter> when you are prompted to enter the password. A message will confirm that the password will be disabled. Once the password is disabled, the system will boot and you can enter Setup freely.

### **PASSWORD DISABLED.**

When a password has been enabled, you will be prompted to enter it every time you try to enter Setup. This prevents an unauthorized person from changing any part of your system configuration.

Additionally, when a password is enabled, you can also require the BIOS to request a password every time your system is rebooted. This would prevent unauthorized use of your computer.

You determine when the password is required within the BIOS Features Setup Menu and its Security option. If the Security option is set to "System", the password will be required both at boot and at entry to Setup. If set to "Setup", prompting only occurs when trying to enter Setup.

### 3-13 Load Optimized /Standard Defaults

#### Load Optimized Defaults

When you press <Enter> on this item, you get a confirmation dialog box with a message similar to:



Pressing <OK> loads the default values that are factory settings for optimal performance system operations.

#### Load Standard Defaults

When you press <Enter> on this item, you get a confirmation dialog box with a message similar to:



Pressing <OK> loads the default values that are factory settings for stable performance system operations.

## 3-14 Save & Exit Setup/ Exit Without Saving

### Save and Exit Setup

When you press <Enter> on this item, you get a confirmation dialog box with a message similar to:



Pressing <OK> save the values you made previously and exit BIOS setup.

### Exit Without Saving

When you press <Enter> on this item, you get a confirmation dialog box with a message similar to:



Pressing <OK> to leave BIOS setting without saving previously set values.