

Technical Manual
Of
Intel Bay Trail Series CPU
Based Mini-ITX M/B

NO.G03-NF9W-F

Revision: 2.0

Release date: October 1, 2019

Trademark:

- * Specifications and Information contained in this documentation are furnished for information use only, and are subject to change at any time without notice, and should not be construed as a commitment by manufacturer.

Environmental Protection Announcement

Do not dispose this electronic device into the trash while discarding. To minimize pollution and ensure environment protection of mother earth, please recycle.



TABLE OF CONTENT

ENVIRONMENTAL SAFETY INSTRUCTION.....	iv
USER'S NOTICE	v
MANUAL REVISION INFORMATION	v
ITEM CHECKLIST	v
CHAPTER 1 INTRODUCTION OF THE MOTHERBOARD	
1-1 FEATURE OF MOTHERBOARD	1
1-2 SPECIFICATION	2
1-3 LAYOUT DIAGRAM	3
CHAPTER 2 HARDWARE INSTALLATION	
2-1 JUMPER SETTING	8
2-2 CONNECTORS AND HEADERS.....	13
2-2-1 CONNECTORS	13
2-2-2 HEADERS	18
CHAPTER 3 INTRODUCING BIOS	
3-1 ENTERING SETUP	25
3-2 BIOS MENU SCREEN	26
3-3 FUNCTION KEYS	26
3-4 GETTING HELP	27
3-5 MEMU BARS.....	27
3-6 MAIN MENU	28
3-7 ADVANCED MENU	29
3-8 CHIPSET MENU.....	39
3-9 SECURITY MENU	42
3-10 BOOT MENU.....	43
3-11 SAVE & EXIT MENU	44



Environmental Safety Instruction

- Avoid the dusty, humidity and temperature extremes. Do not place the product in any area where it may become wet.
- 0 to 60 centigrade is the suitable temperature. (The figure comes from the request of the main chipset)
- Generally speaking, dramatic changes in temperature may lead to contact malfunction and crackles due to constant thermal expansion and contraction from the welding spots' that connect components and PCB. Computer should go through an adaptive phase before it boots when it is moved from a cold environment to a warmer one to avoid condensation phenomenon. These water drops attached on PCB or the surface of the components can bring about phenomena as minor as computer instability resulted from corrosion and oxidation from components and PCB or as major as short circuit that can burn the components. Suggest starting the computer until the temperature goes up.
- The increasing temperature of the capacitor may decrease the life of computer. Using the close case may decrease the life of other device because the higher temperature in the inner of the case.
- Attention to the heat sink when you over-clocking. The higher temperature may decrease the life of the device and burned the capacitor.

USER'S NOTICE

COPYRIGHT OF THIS MANUAL BELONGS TO THE MANUFACTURER. NO PART OF THIS MANUAL, INCLUDING THE PRODUCTS AND SOFTWARE DESCRIBED IN IT MAY BE REPRODUCED, TRANSMITTED OR TRANSLATED INTO ANY LANGUAGE IN ANY FORM OR BY ANY MEANS WITHOUT WRITTEN PERMISSION OF THE MANUFACTURER.

THIS MANUAL CONTAINS ALL INFORMATION REQUIRED TO USE THIS MOTHER-BOARD SERIES AND WE DO ASSURE THIS MANUAL MEETS USER'S REQUIREMENT BUT WILL CHANGE, CORRECT ANY TIME WITHOUT NOTICE. MANUFACTURER PROVIDES THIS MANUAL "AS IS" WITHOUT WARRANTY OF ANY KIND, AND WILL NOT BE LIABLE FOR ANY INDIRECT, SPECIAL, INCIDENTAL OR CONSEQUENTIAL DAMAGES (INCLUDING DAMAGES FOR LOSS OF PROFIT, LOSS OF BUSINESS, LOSS OF USE OF DATA, INTERRUPTION OF BUSINESS AND THE LIKE).

PRODUCTS AND CORPORATE NAMES APPEARING IN THIS MANUAL MAY OR MAY NOT BE REGISTERED TRADEMARKS OR COPYRIGHTS OF THEIR RESPECTIVE COMPANIES, AND THEY ARE USED ONLY FOR IDENTIFICATION OR EXPLANATION AND TO THE OWNER'S BENEFIT, WITHOUT INTENT TO INFRINGE.

Manual Revision Information

Reversion	Revision History	Date
2.0	Second Edition	October 1, 2019

Item Checklist

- Motherboard
- Cable(s)

Chapter 1

Introduction of the Motherboard

1-1 Feature of Motherboard

- Onboard Intel® Bay Trail Series Processor, with low power consumption never denies high performance
- Support 1* DDR3L 1066/1333 MHz SO-DIMM, up to 8GB
- Support full-size Mini-PCIE connector
- Support 2 * SATAII device & 2 * SATAIII device
- Support USB 3.0 data transport demand
- Support LVDS & DVI-I dual display output
- Support CPU Over-Temperature protection
- Support CPU Over-Current/Under Voltage protection
- Support DRAM Over-Current/Under Voltage protection
- Amplifier implement to support 3W Speaker
- Support CPU Smart FAN
- Compliance with ErP standard
- Support Watchdog function

1-2 Specification

Spec	Description
Design	<ul style="list-style-type: none">● 6 layers; PCB size: 17x 17 cm
Embedded CPU	<ul style="list-style-type: none">● Integrated with Intel[®] Bay Trail-D/M/I series CPU
Memory Slot	<ul style="list-style-type: none">● 1 * DDR3L SODIMM Slot for un-buffered DDR3L 1066/1333 MHz SDRAM, expandable to 8GB in total
Expansion Slot	<ul style="list-style-type: none">● 1* Full-size Mini-PCIE slot● 1* PCIE x1 slot
LAN Chip	<ul style="list-style-type: none">● Integrated with Realtek RTL8111G PCI-E Gigabit LAN chip● Support Fast Ethernet LAN function of providing 10/100/1000Mbps Ethernet data transfer rate
Storage	<ul style="list-style-type: none">● 2* SATAII port (SATA1/2)● 2* SATAIII port (SATA3/4)
BIOS	<ul style="list-style-type: none">● AMI 64MB Flash ROM
Rear I/O	<ul style="list-style-type: none">● 1* 12V system DC Jack power-in connector● 1* USB 3.0 port● 3* USB 2.0 port● 1* DVI-I port● 1* COM1 serial port(COM1 supports RS422/485 function)● 1* RJ-45 LAN port● Audio Line Out port x1
Internal I/O	<ul style="list-style-type: none">● 1* 2-Pin DC 12V system power-in connector● 1* 2-Pin DC 12V power-out connector● 2* SATA Power-out connector● 1* CPUFAN header● 2* SYSFAN header ● 1* Front panel audio header● 1* SPDIF Out header

	<ul style="list-style-type: none"> ● 1* SPEAK_CON header ● 1* 4-pin USB 2.0 header (Expansible to 1* USB 2.0 port) ● 2* 9-pin USB 2.0 header (Expansible to 4* USB 2.0 ports) ● 1* Front panel header ● 1* Power LED & speaker header ● 1* Serial port header ● 1* GPIO_CON header ● 1* SMBUS header ● 1* LAN LED activity header ● 1* LVDS header ● 1* LVDS inverter header
--	---

1-3 Layout Diagram

Rear IO Panel Diagram:

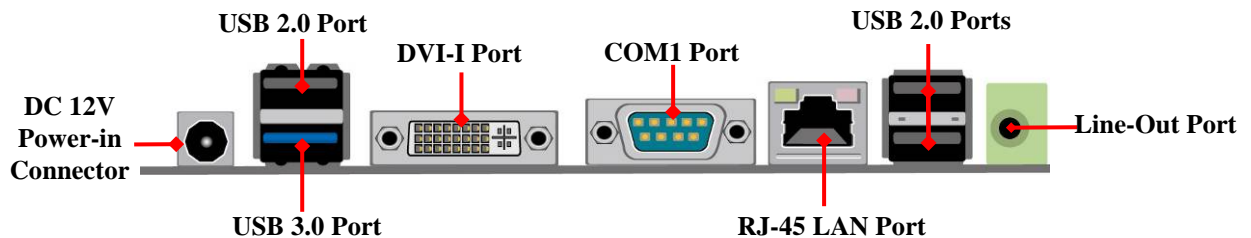

Warning!

The board has a DC 12V power connector (DCIN) in I/O back panel and an internal ATX12V (ATX2P) power connector. User can only connect one type of compatible power supply to one of them to power the system.

Motherboard Internal Diagram

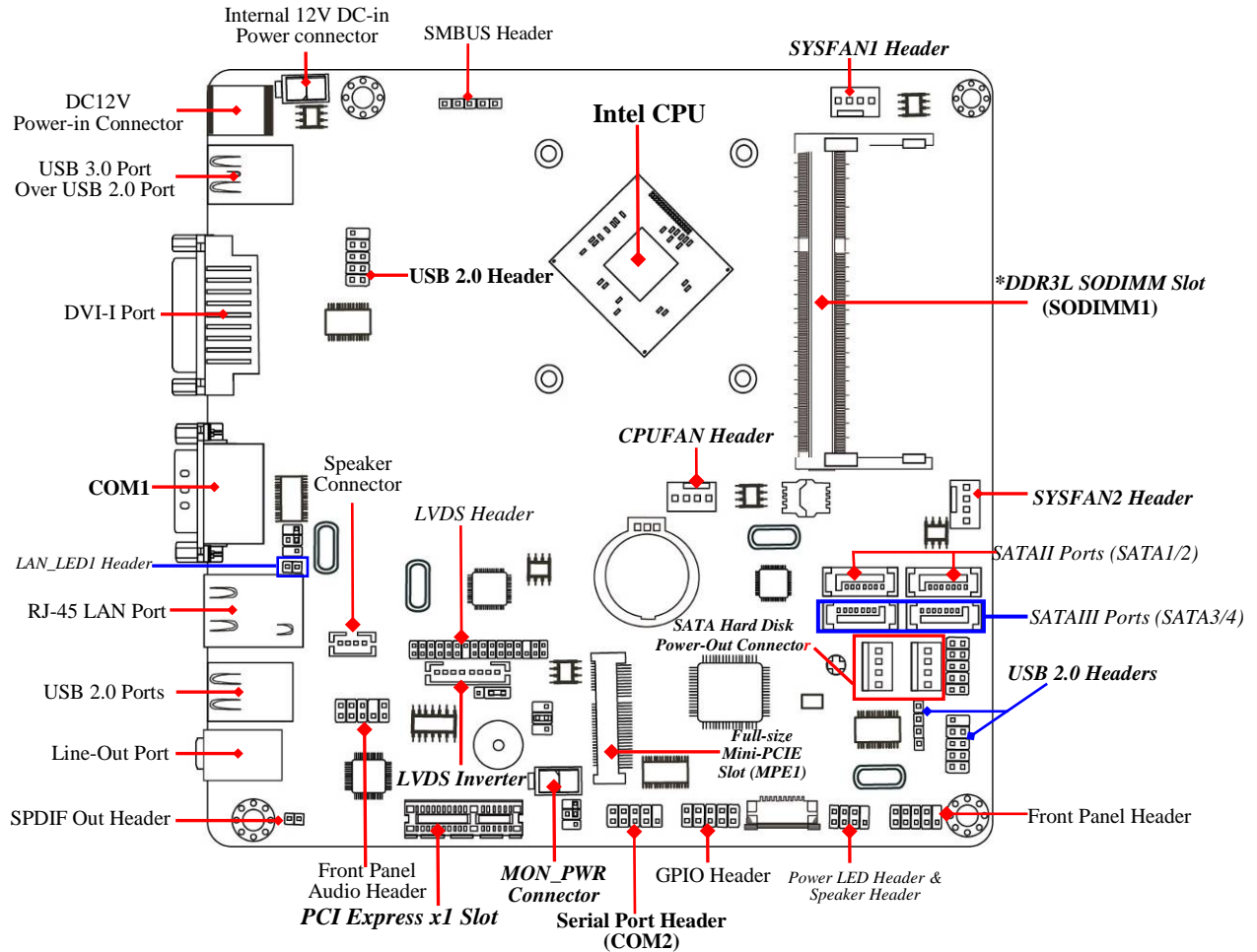

Note: The memory module should be **DDR3L 1.35V SODIMM** and **not exceeding 8GB total capacity**.

Jumper Position:

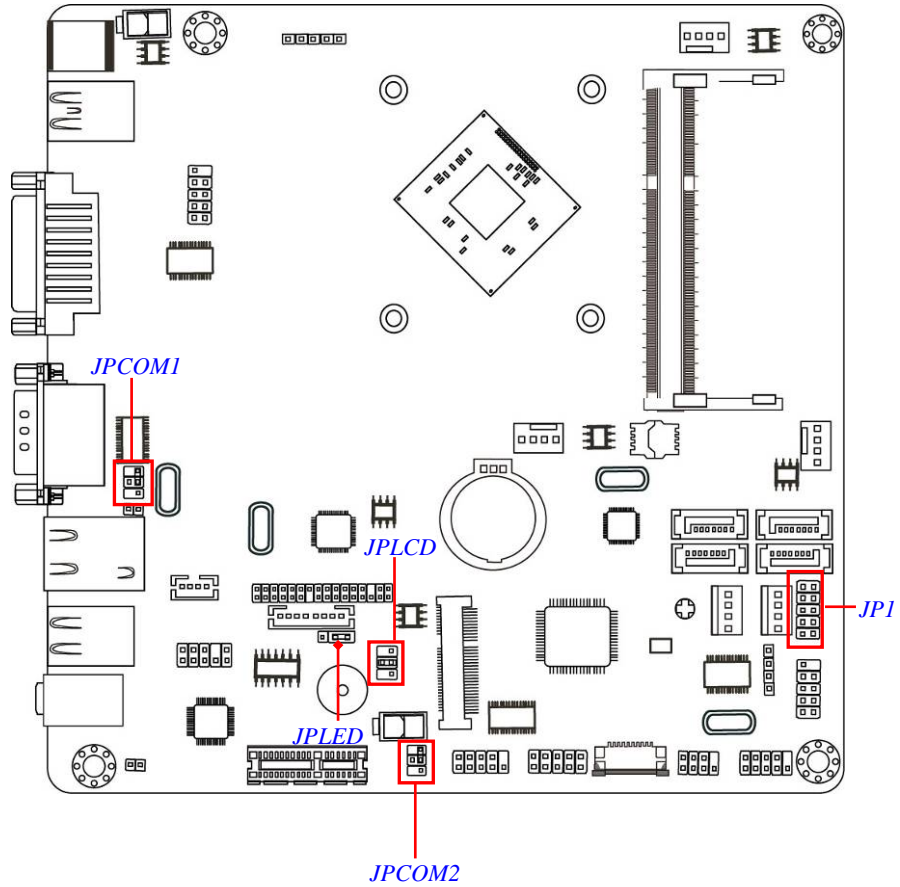

Jumper

Jumper	Name	Description
JP1	<i>Pin 1-2:</i> Clear ME Function Setting <i>Pin 3-4:</i> Clear CMOS RAM Function Setting <i>Pin 5-6:</i> ATX Mode & AT Mode Select <i>Pin 7-8:</i> ME Security Measure Function Select <i>Pin 9-10:</i> Case Open Message Display Function	10-Pin Block
JPLED	INVERTER Back Light 5V/12V Select	3-Pin Block
JPLCD	LVDS PVCC 5V/3.3V /12V Select	4-Pin Block
JPCOM1	COM1 Port Pin9 Function Select	4-Pin Block
JPCOM2	COM2 Header Pin9 Function Select	4-Pin Block

Connectors

Connector	Name
DCIN	DC 12V System Power-in Connector
ATX2P	Internal DC 12V System Power-in Connector
MON_PWR	DC 12V Power-out Connector
SATA1/2	SATAII Port Connector X2
SATA3/4	SATAIII Port Connector X2
SATAPW1/2	SATA Power out Connector X2
CPUFAN	CPUFAN Connector
SYSFAN1/SYSFAN2	SYSFAN Connector X2
USB1(Top) /USB2	USB 2.0 Port Connector X3
USB1(Bottom)	USB 3.0 Port Connector
DVI-CRT1	DVI-I Port Connector
COM1	Serial Port Connector
LAN	RJ-45 LAN Port Connector

Headers

Header	Name	Description
FP_AUDIO	Front Panel Audio Header	9-pin Block
SPDIF	SPDIF Out Header	2-pin Block
SPEAK_CON	Speaker Header	4-pin Block
FP_USB1/2	USB 2.0 Header	9-pin Block
FP_USB3	USB 2.0 Header	4-pin Block
JW_FP1	Front Panel Header(PWR LED/ HDD LED/Power Button /Reset)	9-pin Block
SPK-LED1	Power LED & Speaker Header	7-pin Block
COM2	Serial Port Header X1	9-pin Block
GPIO_CON1	GPIO Header	10-pin Block
SMBUS1	SMBUS Header	5-pin Block
LAN_LED1	LAN Activity LED Header	2-pin Block
LVDS	LVDS Header	30-pin Block
INVERTER	LVDS Inverter	8-pin Block

Chapter 2

Hardware Installation

2-1 Jumper Setting

Pin 1 & 2 of JP1 (10-pin): Clear ME Function Setting

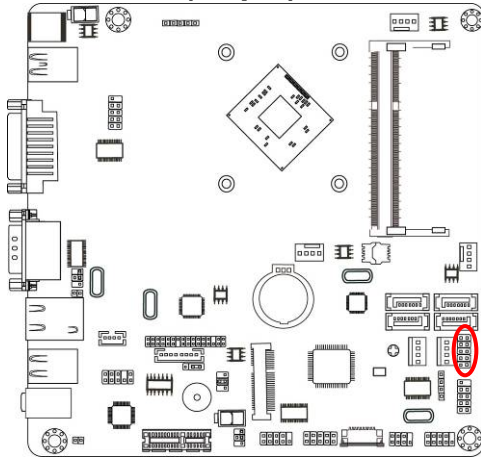

Pin 1-2 of JP1 → Clear ME

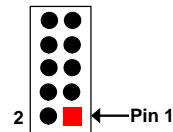

1-2 Open: Normal(Default);

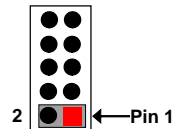

1-2 Closed: Clear ME.

Pin 3 & 4 of JP1 (10-pin): Clear CMOS Setting

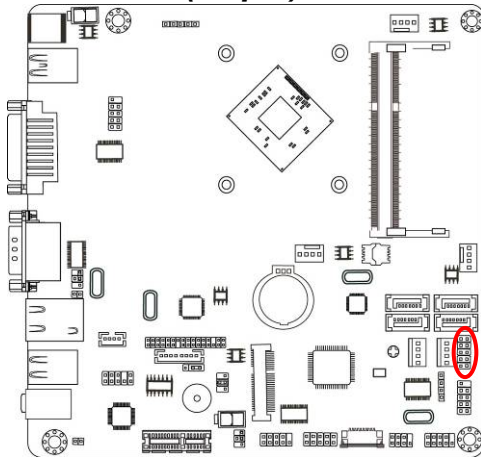

Pin 3-4 of JP1 → Clear CMOS

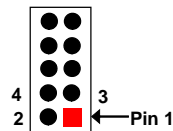

3-4 Open: Normal(Default);

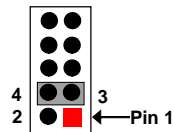

3-4 Closed: Clear CMOS(One Touch).

Pin 5 & 6 of JP1 (10-pin): AT Mode Select

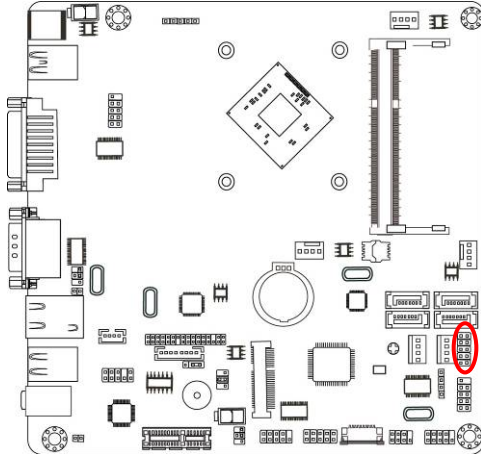

Pin 5-6 of JP1 → AT Mode Select

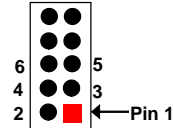

5-6 Open: ATX Mode Selected(Default);

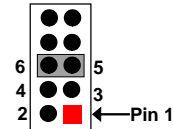

5-6 Closed: AT Mode Selected.

***ATX Mode Selected:** Press power button to power on after power input ready;
AT Mode Selected: Directly power on as power input ready.

Pin 7 & 8 of JP1 (10-pin): ME Security Measure Function Select

Pin 7-8 of JP1 → ME Security Function Select

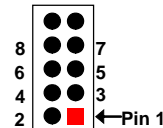
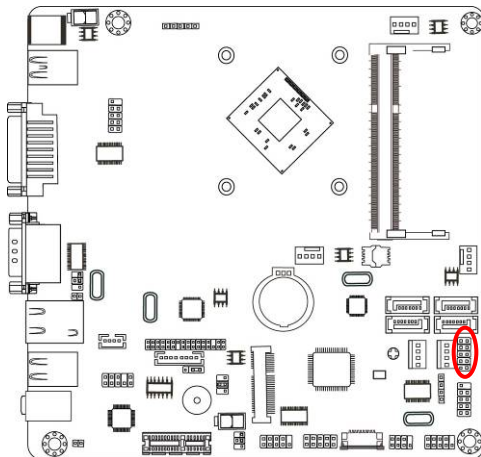

7-8 Open: Enable Security Measures in the Flash Descriptor(Default);

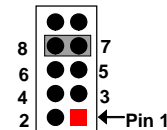

7-8 Closed: Disable Security Measures in the Flash Descriptor(Override).

Pin 9 & 10 of JP1 (10-pin): Case Open Message Display Function Select

Pin 9-10 of JP1 → Case Open

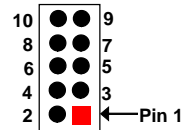
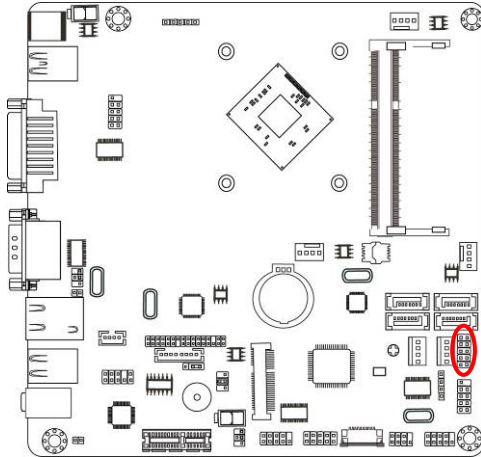

9-10 Open: Normal(Default);

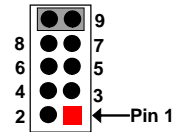

9-10 Closed: Case Open Function Selected(One Touch).

Pin 9-10 Close: When Case open function pin short to GND, the Case open function was detected. When Used, needs to enter BIOS and enable 'Case Open Detect' function. In this case if your case is removed, next time when you restart your computer, a message will be displayed on screen to inform you of this.

JPLED (3-pin): INVERTER Back Light VCC 5V/12V Select

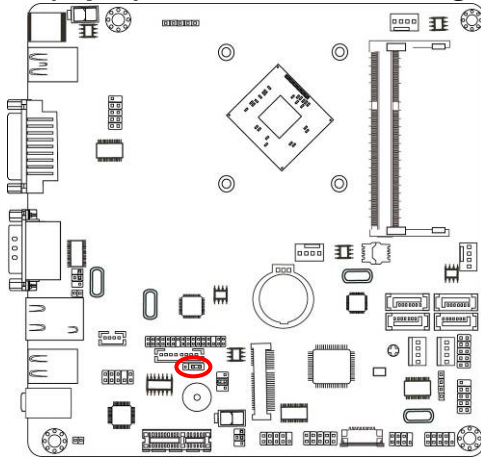

JPLED→INVERTER Back Light VCC

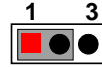

1-2 Close: INVERTER Back Light 5V Selected(Default);

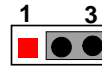

2-3 Close: INVERTER Back Light 12V Selected.

JPLCD (4-pin): LCD PVCC VCC3.3V/5V/12V Select

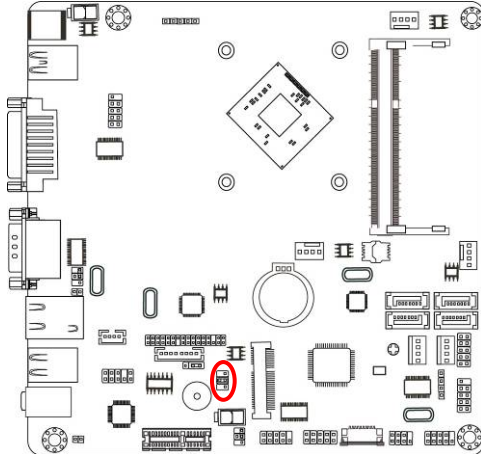

JPLCD→LCD PVCC

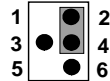

**2-4 Closed:
VCC=3.3V
(Default);**

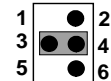

**3-4 Closed:
VCC= 5V;**

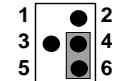

**4-6 Closed:
VCC= 12V.**

JPCOM1 (4-pin): COM1 Port Pin9 Function Select

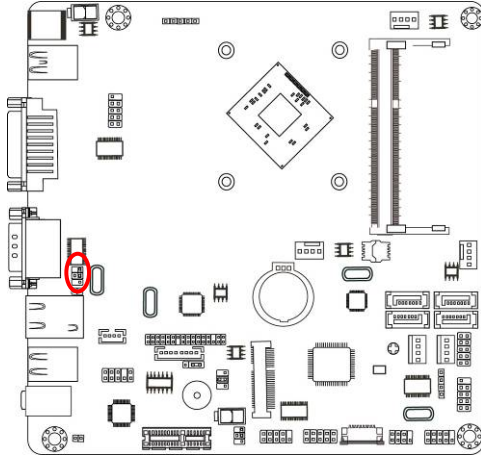

JPCOM1 → COM1 Port Pin-9



2-4 Closed:
RI=RS232(Default);

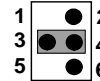

3-4 Closed:
RI= 5V;

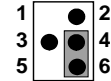

4-6 Closed:
RI= 12V.

JPCOM2 (4-pin): COM2 Header Pin9 Function Select

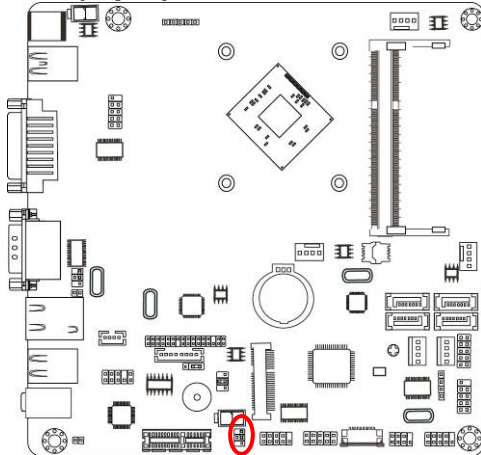

JPCOM2 → COM2 Header Pin-9



2-4 Closed:
RI=RS232(Default);

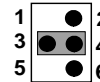

3-4 Closed:
RI= 5V;

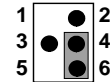

4-6 Closed:
RI= 12V.

2-2 Connectors and Headers

2-2-1 Connectors

(1) Rear I/O Connectors

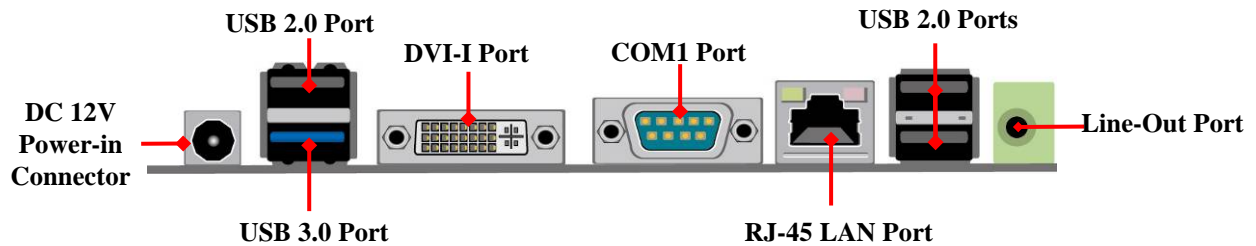

(2) COM1 (9-pin Block): RS232/422/485 Port

COM1 port can function as RS232/422/485 port. In normal settings COM1 functions as RS232 port. With compatible COM cable COM1 can function as RS422 or RS 485 port.

User also needs to go to BIOS to set '**Transmission Mode Select**' for COM1 (*refer to Page 30*) at first, before using specialized cable to connect different pins of this port.

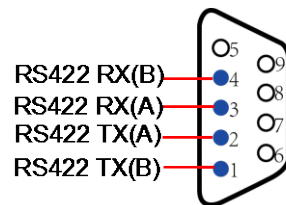

For RS422 Mode

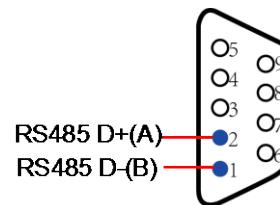

For RS485 Mode

(3) ATX2P (2-pin Block): DC 12V Power-in Connector

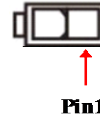
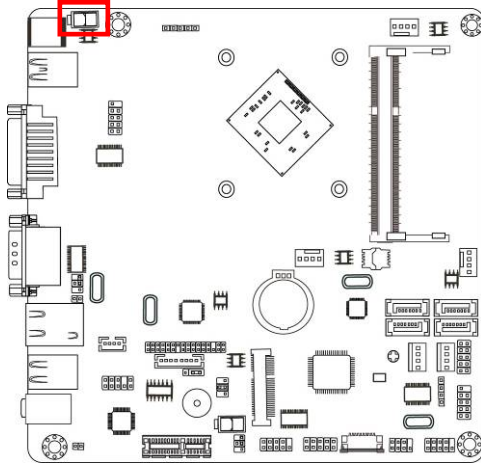

Pin.	Definition
1	GND
2	+12V DC_IN

(4) MON_PWR(2-pin Block): DC 12V Power-out Connector

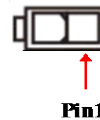
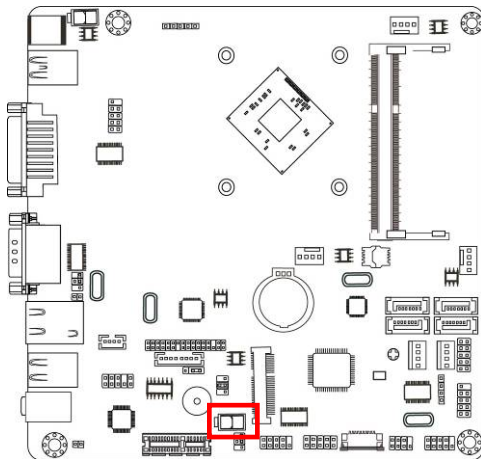

Pin.	Definition
1	GND
2	+12V

(5) SATA1/SATA2(7-pin Block): SATAII Port connector

These are high-speed SATAII ports that support 3GB/s transfer rate.

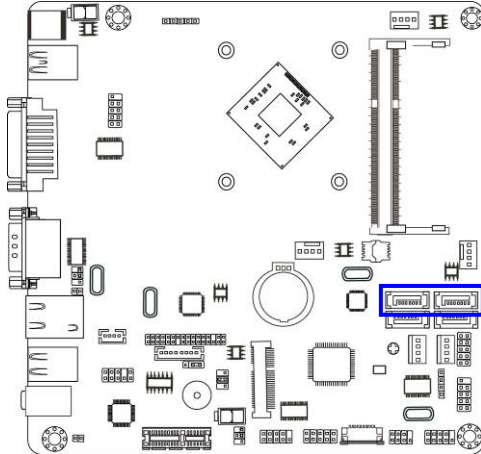

Pin No.	Definition
1	GND
2	TXP
3	TXN
4	GND
5	RXN
6	RXP
7	GND

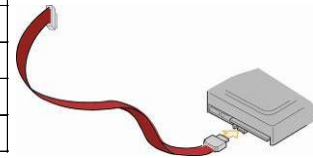

(6) SATA3/SATA4(7-pin Block): SATAIII Port connector

These are high-speed SATAIII ports that support 6GB/s transfer rate.

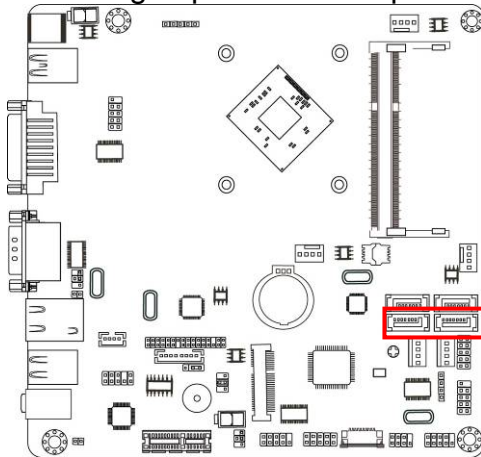

Pin No.	Definition
1	GND
2	TXP
3	TXN
4	GND
5	RXN
6	RXP
7	GND

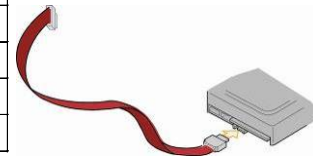

(7) SATAPW1/SATAPW2(4-pin): SATA Power Out Connector

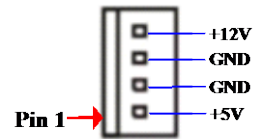
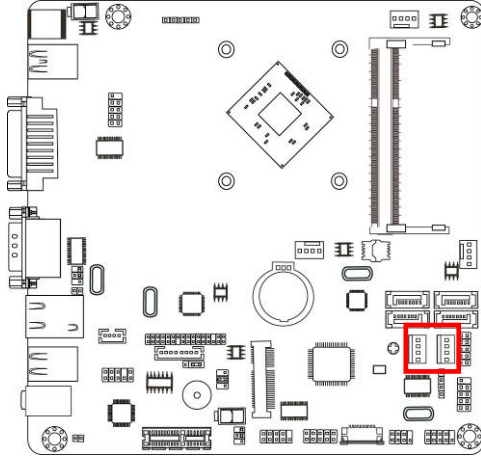

(8) CPUFAN1 (4-pin): CPUFAN Connector

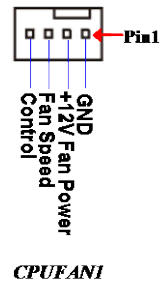
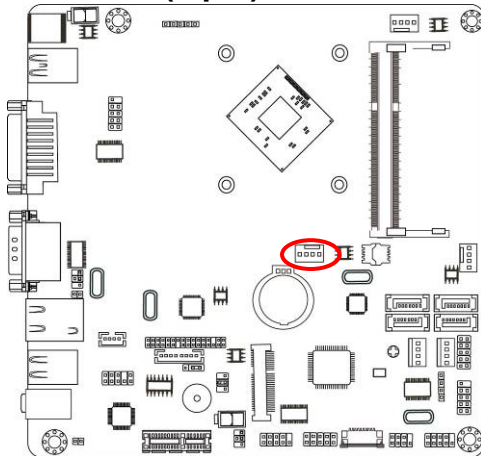

(9) SYSFAN1 (4-pin): SYSFAN1 Connector

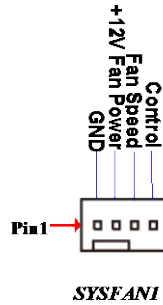
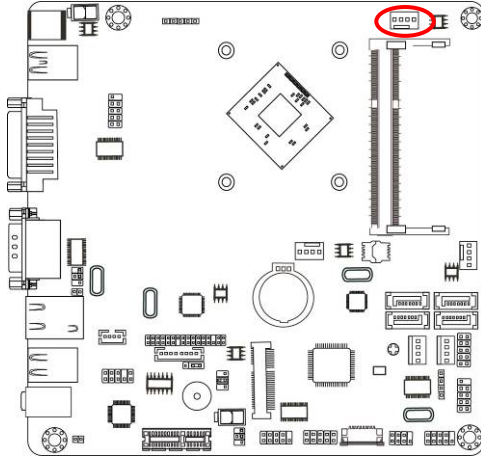

(10) SYSFAN2 (4-pin): SYSFAN2 Connector

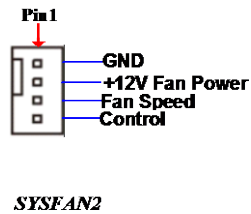
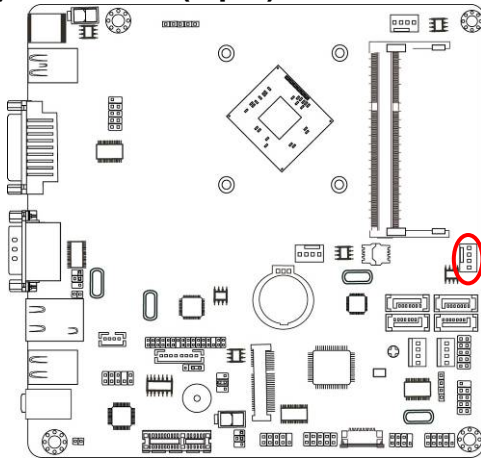

2-2-2 Headers

(1) FP_AUDIO (9-pin): Line-Out, MIC-In Header

This header connects to Front Panel Line-out, MIC-In connector with cable.

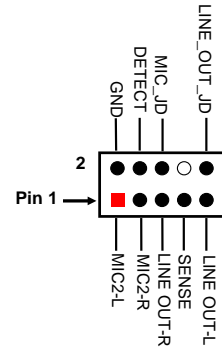
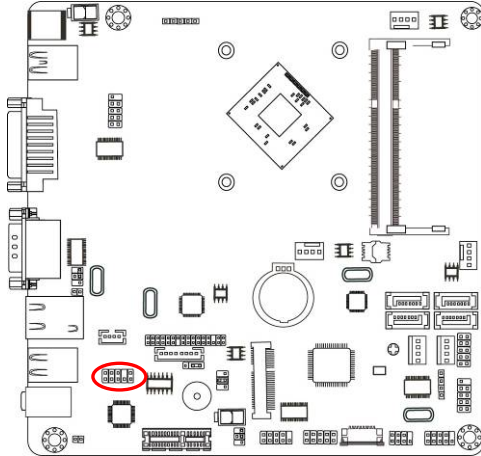

Line-Out, MIC Header

(2) SPDIF (2-pin): SPDIF Out Header

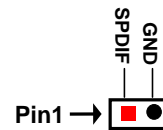
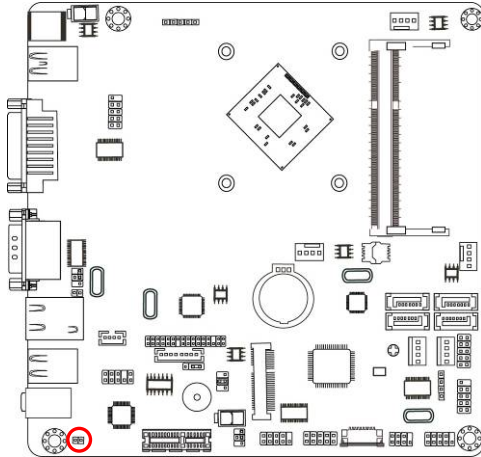

(3)SPEAK CON (4-pin): Speaker Connector

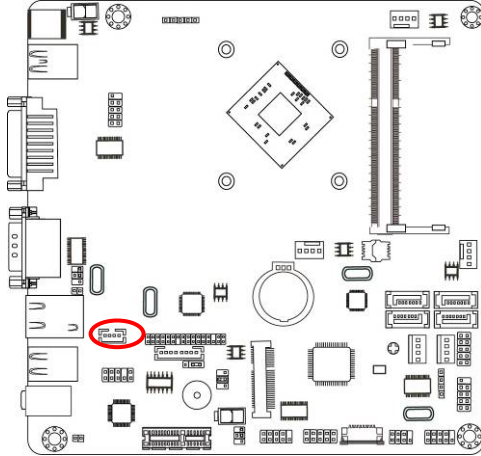

Pin No.	Definition
1	L-
2	L+
3	R+
4	R-

(4) FP_USB1/FP_USB2 (9-pin): USB 2.0 Port Header

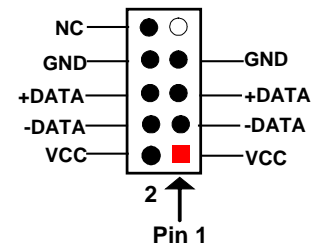
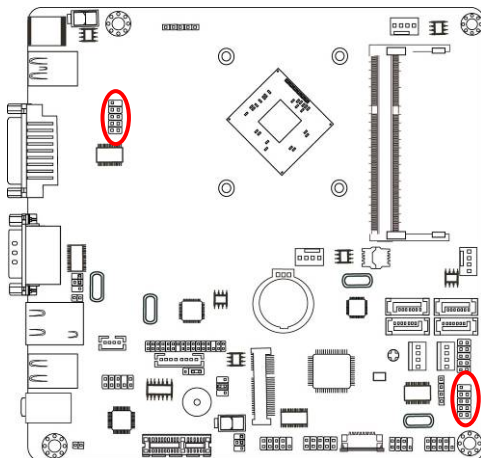

(5) FP_USB3 (4-pin): USB 2.0 Port Header

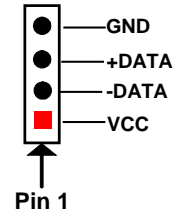
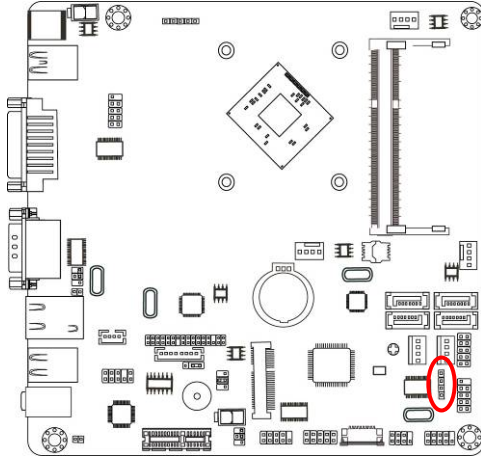

(6) JW_FP (9-pin): Front Panel Header

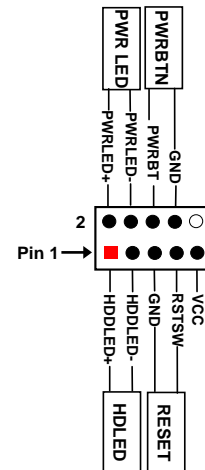
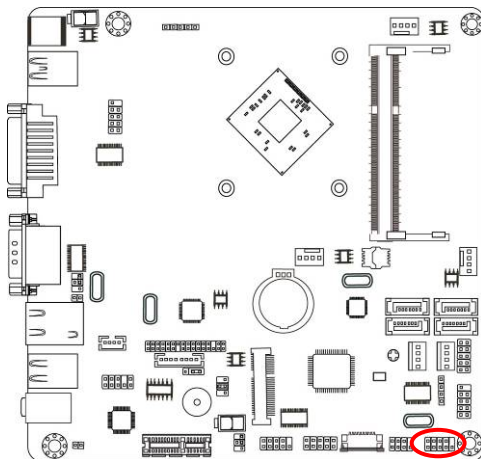

(7) SPK-LED (7-pin): Speaker Header & PWR LED Header

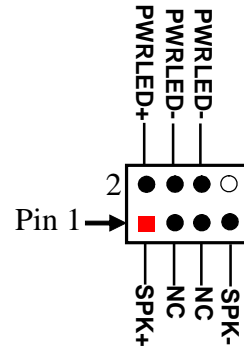
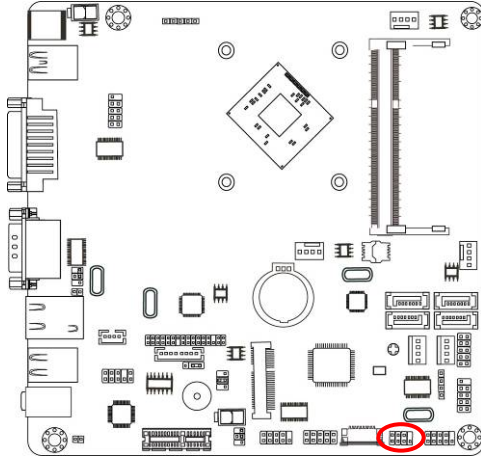

(8) COM2 (9-pin): Serial Port Header

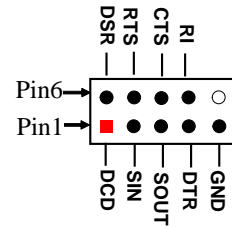
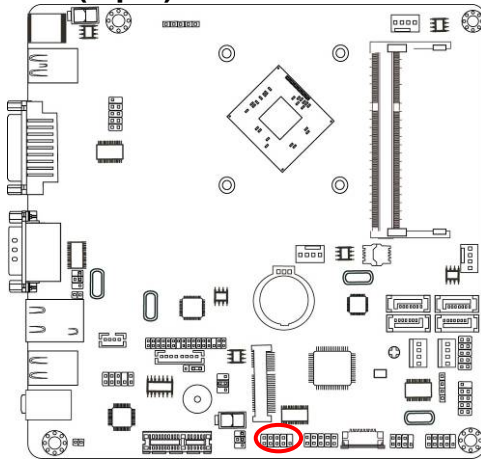

(9) GPIO_CON (10-pin): GPIO Header

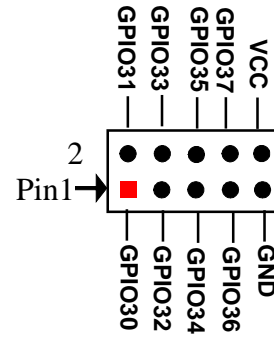
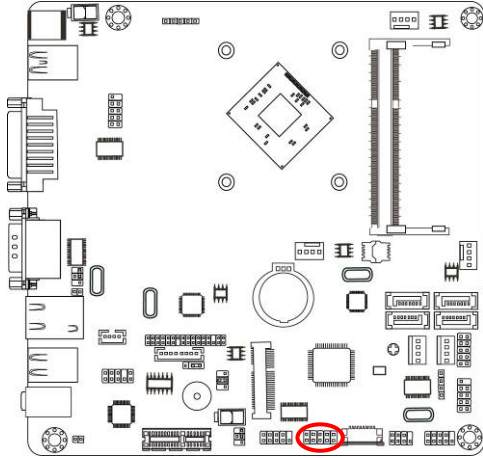

(10) SMBUS1 (5-Pin): SM BUS Header

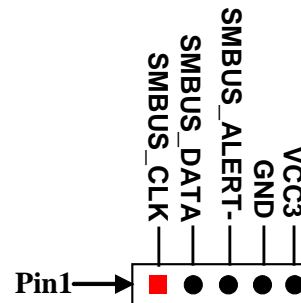
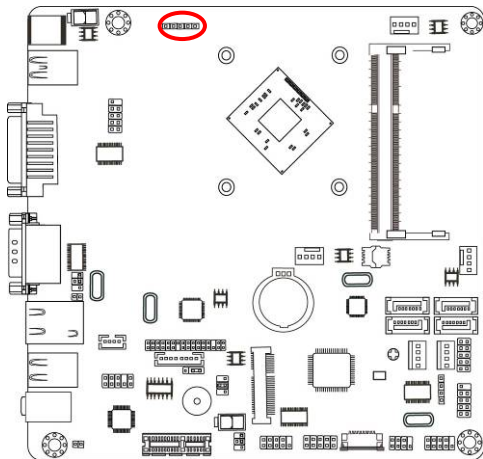

(11) LAN_LED1 (2-pin): LAN Activity LED Header

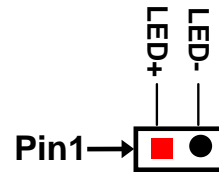
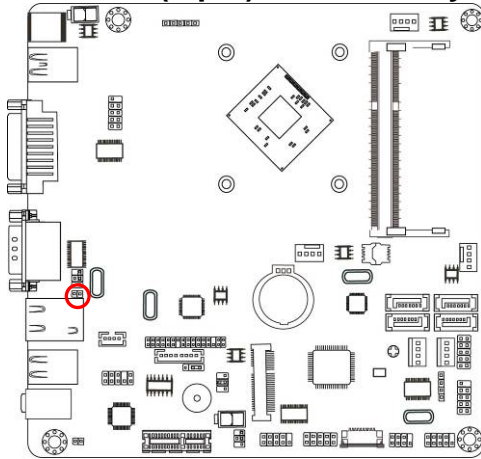

(12) INVERTER (8-pin): LVDS Inverter Connector

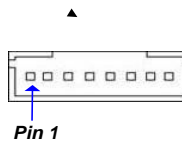
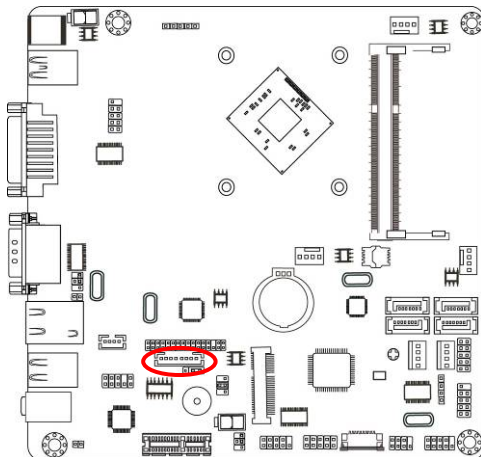

Pin No.	Definition
1	Backlight Enable
2	Backlight PWM
3	Backlight VCC
4	Backlight VCC
5	GND
6	GND
7	Backlight Up SW
8	Backlight Down SW

(13) LVDS (30-pin): 24-bit Dual Channel LVDS Header

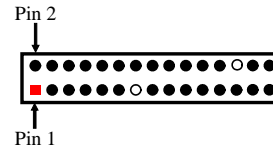
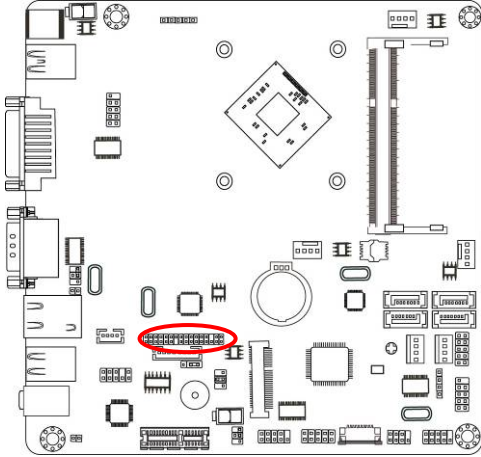

Pin NO.	Pin Define	Pin NO.	Pin Define
Pin 1	LVDSB_DATAN3	Pin 2	LVDSB_DATAP3
Pin 3	LVDS_CLKBN	Pin 4	LVDS_CLKBP
Pin 5	LVDSB_DATAN2	Pin 6	LVDSB_DATAP2
Pin 7	LVDSB_DATAN1	Pin 8	LVDSB_DATAP1
Pin 9	LVDSB_DATAN0	Pin 10	LVDSB_DATAP0
Pin 11	LVDS_DDC_DAT	Pin 12	LVDS_DDC_CLK
Pin 13	N/A	Pin 14	GND
Pin 15	GND	Pin 16	GND
Pin 17	LVDSA_DATAP3	Pin 18	LVDSA_DATAN3
Pin 19	LVDS_CLKAP	Pin 20	LVDS_CLKAN
Pin 21	LVDSA_DATAP2	Pin 22	LVDSA_DATAN2
Pin 23	LVDSA_DATAP1	Pin 24	LVDSA_DATAN1
Pin 25	LVDSA_DATAP0	Pin 26	LVDSA_DATAN0
Pin 27	PVDD	Pin 28	N/A
Pin 29	PVDD	Pin 30	PVDD
Pin 31	GND	Pin 32	GND

Chapter 3

Introducing BIOS

Notice! The BIOS options in this manual are for reference only. Different configurations may lead to difference in BIOS screen and BIOS screens in manuals are usually the first BIOS version when the board is released and may be different from your purchased motherboard. Users are welcome to download the latest BIOS version form our official website.

The BIOS is a program located on a Flash Memory on the motherboard. This program is a bridge between motherboard and operating system. When you start the computer, the BIOS program will gain control. The BIOS first operates an auto-diagnostic test called POST (power on self test) for all the necessary hardware, it detects the entire hardware device and configures the parameters of the hardware synchronization. Only when these tasks are completed done it gives up control of the computer to operating system (OS). Since the BIOS is the only channel for hardware and software to communicate, it is the key factor for system stability, and in ensuring that your system performance as its best.

3-1 Entering Setup

Power on the computer and by pressing immediately allows you to enter Setup. If the message disappears before your respond and you still wish to enter Setup, restart the system to try again by turning it OFF then ON or pressing the “RESET” button on the system case. You may also restart by simultaneously pressing <Ctrl>, <Alt> and <Delete> keys. If you do not press the keys at the correct time and the system does not boot, an error message will be displayed and you will again be asked to

Press **** to enter Setup; press **< F7>** for Pop Menu.

3-2 BIOS Menu Screen

The following diagram show a general BIOS menu screen:

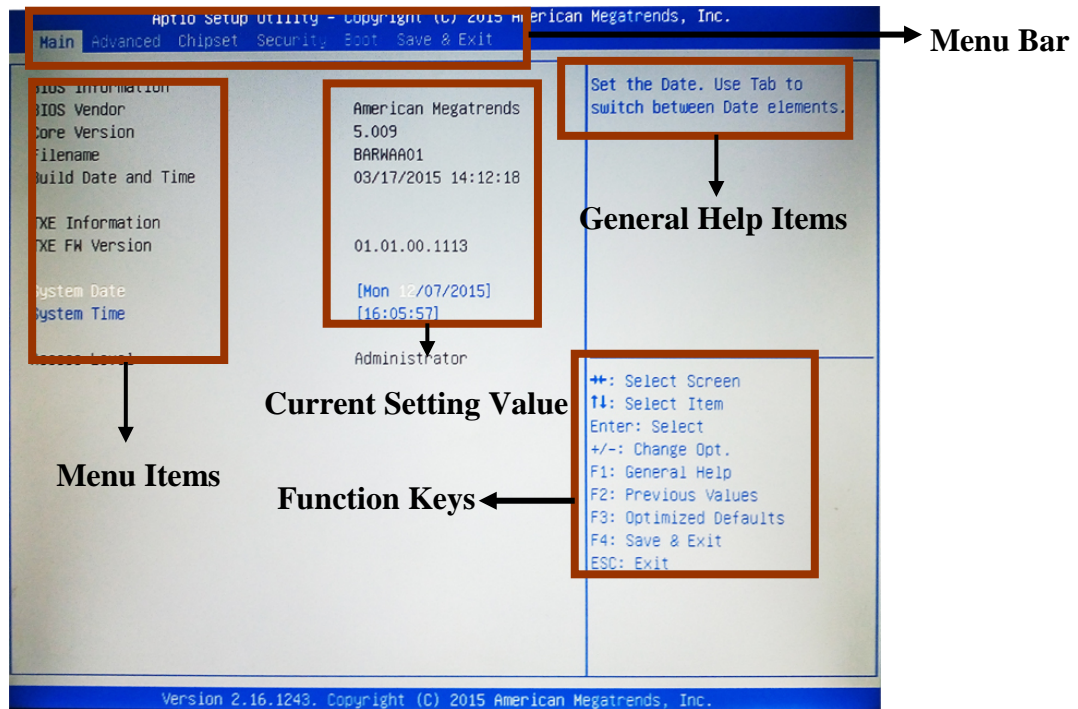

BIOS Menu Screen

3-3 Function Keys

In the above BIOS Setup main menu of, you can see several options. We will explain these options step by step in the following pages of this chapter, but let us first see a short description of the function keys you may use here:

- Press←→ (left, right) to select screen;

-
-
- Press ↑↓ (up, down) to choose, in the main menu, the option you want to confirm or to modify.
 - Press <Enter> to select.
 - Press <+>/<-> keys when you want to modify the BIOS parameters for the active option.
 - [F1]: General help.
 - [F2]: Previous value.
 - [F3]: Optimized defaults.
 - [F4]: Save & Exit.
 - Press <Esc> to quit the BIOS Setup.

3-4 Getting Help

Main Menu

The on-line description of the highlighted setup function is displayed at the top right corner the screen.

Status Page Setup Menu/Option Page Setup Menu

Press F1 to pop up a small help window that describes the appropriate keys to use and the possible selections for the highlighted item. To exit the Help Window, press <Esc>.

3-5 Menu Bars

There are six menu bars on top of BIOS screen:

Main	To change system basic configuration
Advanced	To change system advanced configuration
Chipset	To change chipset configuration
Security	Password settings
Boot	To change boot settings
Save & Exit	Save setting, loading and exit options.

User can press the right or left arrow key on the keyboard to switch from menu bar. The selected one is highlighted.

3-6 Main Menu

Main menu screen includes some basic system information. Highlight the item and then use the <+> or <-> and numerical keyboard keys to select the value you want in each item.

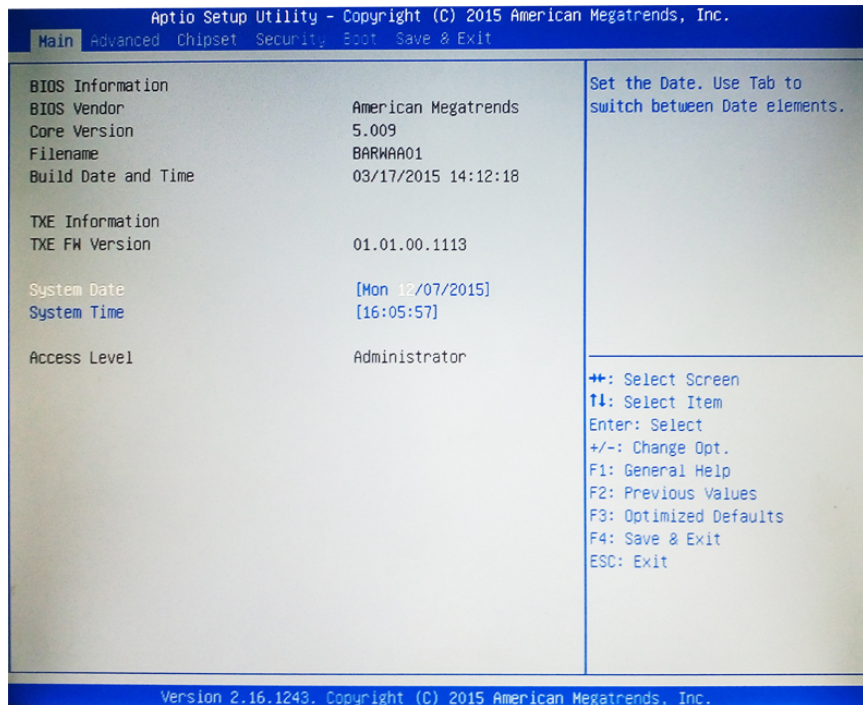

System Date

Set the date. Please use [Tab] to switch between data elements.

System Time

Set the time. Please use [Tab] to switch between time elements.

3-7 Advanced Menu

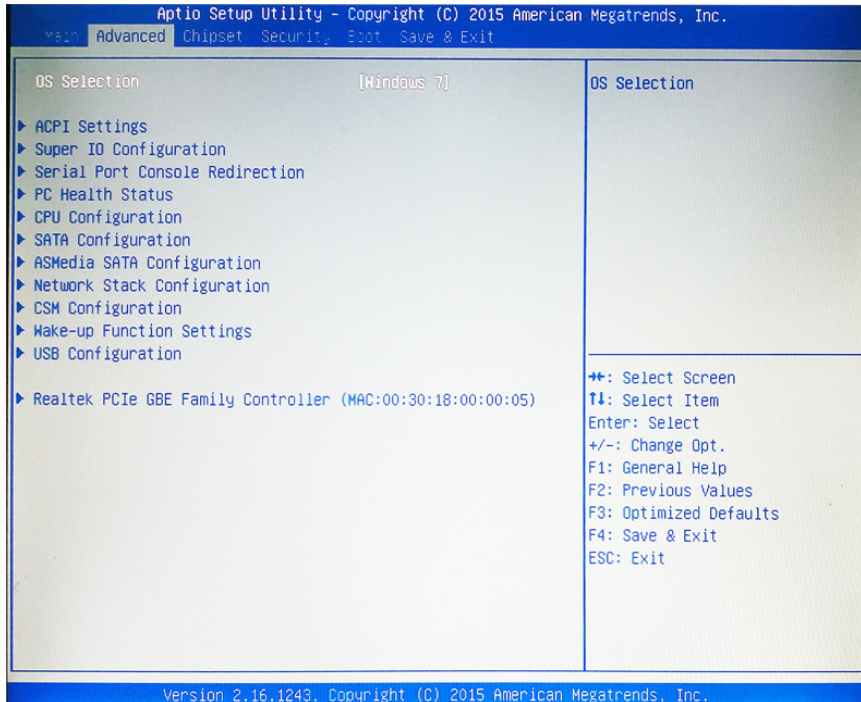

OS Selection

The optional settings: [Windows 8.X]; [Android]; [Windows 7].

***Note:** User needs to go to this item to select OS before installing OS.

If Windows Embedded standard 8, please select [Windows 8x] and set "USB 3.0 Support" as [Disabled], "USB 2.0 Support" as [Enabled] (refer to Page 41).

▶ **ACPI Settings**

Press [Enter] to make settings for the following sub-item:

ACPI Settings

ACPI Sleep State

Use this item to select the highest ACPI sleep state the system will enter when the

suspend button is pressed.

The optional settings are: [Suspend Disabled]; [S3 (Suspend to RAM)].

▶ **Super I/O Configuration**

Press [Enter] to make settings for the following sub-items:

Super IO Configuration

▶ **Serial Port 1 Configuration**

Press [Enter] to make settings for the following items:

Serial Port

Use this item to enable or disable serial port (COM).

Change Settings

Use this item to select an optimal setting for super IO device.

Transmission Mode Select

The optional settings are: [RS422]; [RS232]; [RS485].

Mode Speed Select

The optional settings are: [RS232/RS422/RS485=250kbps]; [RS232=1Mbps, RS422/RS485=10Mbps].

Serial Port FIFO Mode

The optional settings are: [16-Byte FIFO]; [32-Byte FIFO]; [64-Byte FIFO]; [128-Byte FIFO].

▶ **Serial Port 2 Configuration**

Press [Enter] to make settings for the following items:

Serial Port

Use this item to enable or disable serial port (COM).

Change Settings

Use this item to select an optimal setting for super IO device.

Serial Port FIFO Mode

The optional settings are: [16-Byte FIFO]; [32-Byte FIFO]; [64-Byte FIFO]; [128-Byte FIFO].

OS Select for Serial Port

The optional settings are: [Windows]; [LINUX].

ERP Support

The optional settings: [Enabled]; [Disabled].

This item should be set as [Disabled] if you wish to have all active wake-up functions.

Case Open Detect

This item controls detect case open function.

The optional settings are: [Enabled]; [Disabled].

WatchDog Timer

Use this item to enable or disable WatchDog Timer Control. When set as [Enabled], the following sub-items shall appear:

WatchDog Timer Value

User can set a value in the range of [10] to [255].

WatchDog Timer Unit

The optional settings are: [Sec.]; [Min.].

WatchDog Wake-up Timer

This item support WDT wake-up while ERP function is set as [Enabled].

The optional settings are: [Enabled]; [Disabled].

When set as [Enabled], the following sub-items shall appear:

WatchDog Timer Value

The setting range is [10] ~ [4095] seconds, or [1]~[4095] minutes.

WatchDog Timer Unit

The optional settings are: [Sec.]; [Min.].

ATX Power Emulate AT Power

This item displays current Emulate AT Power Status, motherboard power On/Off control by power supply. User needs to select 'AT or ATX Mode' on MB jumper at first (refer to **Page 9**, Jumper AT_MODE for ATX Mode & AT Mode Select).

▶ **Serial Port Console Redirection**

Press [Enter] to make settings for the following sub-items:

COM1/COM2

Console Redirection

Use this item to enable or disable COM1 Console Redirection.

The optional settings are: [Disabled]; [Enabled].

When set as [Enabled], user can make further settings in the 'Console Redirection Settings' screen:

▶ **Console Redirection Settings**

The settings specify how the host computer and the remote computer (which the user is using) will exchange data. Both computers should have the same or compatible settings.

Press [Enter] to make settings for the following sub-items.

Terminal Type

The optional settings are: [VT100]; [VT100+]; [VT-UTF8]; [ANSI].

Bits per second

The optional settings are: [9600]; [19200]; [38400]; [57600]; [115200].

Data Bits

The optional settings are: [7]; [8].

Parity

The optional settings are: [None]; [Even]; [Odd]; [Mark]; [Space].

Stop Bits

The optional settings are: [1]; [2].

Flow Control

The optional settings are: [None]; [Hardware RTS/CTS].

VT-UTF8 Combo Key Support

The optional settings are: [Disabled]; [Enabled].

Recorder Mode

The optional settings are: [Disabled]; [Enabled].

Resolution 100x31

The optional settings are: [Disabled]; [Enabled].

Legacy OS Redirection Resolution

The optional settings are: [80x24]; [80x25].

Putty Keypad

The optional settings are: [VT100]; [LINUX]; [XTERMR6]; [SCO]; [ESCN]; [VT400].

Redirection After BIOS POST

The optional settings are: [Always Enable]; [BootLoader].

Serial Port for Out-of-Band Management/ Windows Emergency Management Services (EMS)

Console Redirection

The optional settings are: [Enabled]; [Disabled].

When set as [Enabled], user can make further settings in 'Console Redirection Settings':

▶ **Console Redirection Settings**

The settings specify how the host computer and the remote computer (which the user is using) will exchange data. Both computers should have the same or compatible settings.

Press [Enter] to make settings for the following sub-items.

Out-of-Band Mgmt Port

The optional settings are: [COM1]; [COM2].

Terminal Type

The optional settings are: [VT100]; [VT100+]; [VT-UTF8]; [ANSI].

Bits per second

The optional settings are: [9600]; [19200]; [57600]; [115200].

Flow Control

The optional settings are: [None]; [Hardware RTS/CTS]; [Software Xon/Xoff].

Data Bits

The default setting is: [8].

**This item may or may not show up, depending on different configuration.*

Parity

The default setting is: [None].

**This item may or may not show up, depending on different configuration.*

Stop Bits

The default setting is: [1].

**This item may or may not show up, depending on different configuration.*

▶ **PC Health Status**

Press [Enter] to view current hardware health status, set shutdown temperature, or make further settings in '**Smart Fan Configuration**'.

▶ **SmartFAN Configuration**

Press [Enter] to make settings for SmartFAN Configuration:

CPUFAN / SYSFAN1/ SYSFAN 2 Smart Mode

The optional settings: [Disabled]; [Enabled].

When set as [Enabled], the following sub-items shall appear:

CPUFAN / SYSFAN1/ SYSFAN 2 Full-Speed Temperature

Use this item to set CPUFAN/SYSFAN1/ SYSFAN2 full speed temperature. Fan will run at full speed when above this temperature.

CPUFAN / SYSFAN1/ SYSFAN 2 Full-Speed Duty

Use this item to set CPUFAN/SYSFAN1/ SYSFAN2 full speed duty. Fan will run at full speed when above the pre-set duty.

CPUFAN / SYSFAN1/ SYSFAN 2 Idle-Speed Temperature

Use this item to set CPUFAN/SYSFAN1/ SYSFAN2 idle speed temperature. Fan will run at idle speed when below this temperature.

CPUFAN / SYSFAN1/ SYSFAN 2 Idle-Speed Duty

Use this item to set CPUFAN/SYSFAN1/ SYSFAN2 idle speed duty.. Fan will run at idle speed when below the pre-set duty.

Shutdown Temperature Configuration

Use this item to select system shutdown temperature.

The optional settings are: [Disabled]; [70°C/156°F]; [75°C/164°F]; [80°C/172°F]; [85°C/180°F];[90°C/188°F].

▶ **CPU Configuration**

Press [Enter] to view current CPU configuration and make settings for the following sub-items:

Limit CPUID Maximum

The optional settings: [Disabled]; [Enabled].

This item should be set as [Disabled] for Windows XP.

Execute Disable Bit

The optional settings: [Disabled]; [Enabled].

Hardware Prefetcher

The optional settings are: [Disabled]; [Enabled].

Use this item to turn on/off the Mid Level Cache (L2) streamer prefetcher.

Adjacent Cache Line Prefetch

The optional settings are: [Disabled]; [Enabled].

Use this item to turn on/off prefetching of adjacent cache lines.

Intel Virtualization Technology

The optional settings: [Enabled]; [Disabled].

When set as [Enabled], a VMM can utilize the additional hardware capabilities provided by Vanderpool Technology.

EIST

The optional settings: [Disabled]; [Enabled].

Use this item to enable or disable Intel SpeedStep.

CPU C6 Report

Use this item to enable or disable CPU C6 (ACPI C3) report to OS.

The optional settings: [Disabled]; [Enabled].

CPU C7 Report

Use this item to enable or disable CPU C7 (ACPI C3) report to OS.

The optional settings: [Disabled]; [Enabled].

Package C-state Limit

The optional settings: [C0]; [C1]; [C3] [C6]; [C7]; [No Limit].

▶ **SATA Configuration**

Press [Enter] to make settings for the following sub-items:

SATA Configuration

SATA Controller

The optional settings: [Disabled]; [Enabled].

SATA Speed Support

The item is for user to set the maximum speed the SATA controller can support.
The optional settings are: [Gen1]; [Gen2].

SATA Mode

The optional settings are: [IDE Mode]; [AHCI Mode].

Serial-ATA Port1/ Serial-ATA Port2

The optional settings are: [Enabled]; [Disabled].

▶ **ASMedia SATA Configuration**

Press [Enter] to make settings for the following sub-item for SATA3/SATA4 port:

SATA Mode

The optional settings are: [IDE Mode]; [AHCI Mode].

▶ **Network Stack Configuration**

Press [Enter] to go to '**Network Stack**' screen to make further settings.

Network Stack

The optional settings are: [Enabled]; [Disabled].

When set as [Enabled], the following sub-items shall appear:

Ipv4 PXE Support

The optional settings are: [Disabled]; [Enabled].

Use this item to enable Ipv4 PXE Boot Support. When set as [Disabled], Ipv4 boot optional will not be created.

Ipv6 PXE Support

The optional settings are: [Disabled]; [Enabled].

Use this item to enable Ipv6 PXE Boot Support. When set as [Disabled], Ipv6 boot optional will not be created.

PXE boot wait time

Use this item to set wait time to press [ESC] key to abort the PXE boot.

▶ **CSM Configuration**

Press [Enter] to make settings for the following sub-items:

Compatibly Support Module Configuration

Boot Option Filter

This item controls Legacy/UEFI ROMs priority.

The optional settings are: [UEFI and Legacy]; [Legacy only]; [UEFI only].

Network

This item controls the execution of UEFI and legacy PXE OpROM.

The optional settings are: [Do not launch]; [UEFI only]; [Legacy only].

Storage

This item controls the execution of UEFI and Legacy Storage OpROM.

The optional settings are: [Do not launch]; [UEFI only]; [Legacy only].

Other PCI devices

This item determines OpROM execution policy for devices other than Network, storage or video.

The optional settings are: [UEFI first]; [Legacy first].

▶ **Wake-up Function Settings**

Press [Enter] to make settings for the following sub-items:

Wake-up System with Fixed Time

Use this item to enable or disable system wake-up by RTC alarm.

The optional settings: [Disabled]; [Enabled].

When set as [Enabled], system will wake on the hour/min/sec specified.

Wake-up System with Dynamic Time

Use this item to enable or disable system wake-up by RTC alarm. The optional settings: [Disabled]; [Enabled].

When set as [Enabled], system will wake on the current time + increased minute(s). The settings range is from [1] ~ [60] minute(s).

USB Wake-up from S3-S4

Use this item to enable or disable USB Wake-up from S3-S4.

The optional settings: [Disabled]; [Enabled].

**This item is only supported when 'ERP Support' is set as [Disabled]. Please disable ERP before activating this function in S4 .*

▶ **USB Configuration**

Press [Enter] to make settings for the following sub-items:

USB Configuration

Legacy USB Support

The optional settings are: [Enabled]; [Disabled]; [Auto].

[Enabled]: To enable legacy USB support.

[Disabled]: To keep USB devices available only for EFI specification,

[Auto]: To disable legacy support if no USB devices are connected.

XHCI Hand-off

This is a workaround for OSES without XHCI hand-off support. The XHCI ownership change should be claimed by XHCI driver.

The optional settings are: [Enabled]; [Disabled].

EHCI Hand-off

This is a workaround for OSES without EHCI hand-off support. The EHCI ownership change should be claimed by EHCI driver.

The optional settings are: [Disabled]; [Enabled].

USB Mass Storage Driver Support

The optional settings are: [Disabled]; [Enabled].

USB Hardware Delays and Time-outs:

USB Transfer Time-out

Use this item to set the time-out value for control, bulk, and interrupt transfers.

The optional settings are: [1 sec]; [5 sec]; [10 sec]; [20 sec].

Device Reset Time-out

Use this item to set USB mass storage device start unit command time-out.

The optional settings are: [10 sec]; [20 sec]; [30 sec]; [40 sec].

Device Power-up Delay

Use this item to set maximum time the device will take before it properly reports itself to the host controller. 'Auto' uses default value: for a root port it is 100 ms, for a hub port the delay is taken from hub descriptor.

The optional settings: [Auto]; [Manual].

Select [Manual] you can set value for the following sub-item: '**Device Power-up Delay in Seconds**'.

Device Power-up Delay in Seconds

The delay range is from [1] to [40] seconds, in one second increments.

- ▶ **Realtek PCIe GBE Family Controller (MAC:XX:XX:XX:XX:XX:XX)**

Use this item to get driver information and configure Realtek ethernet controller parameter.

3-8 Chipset Menu

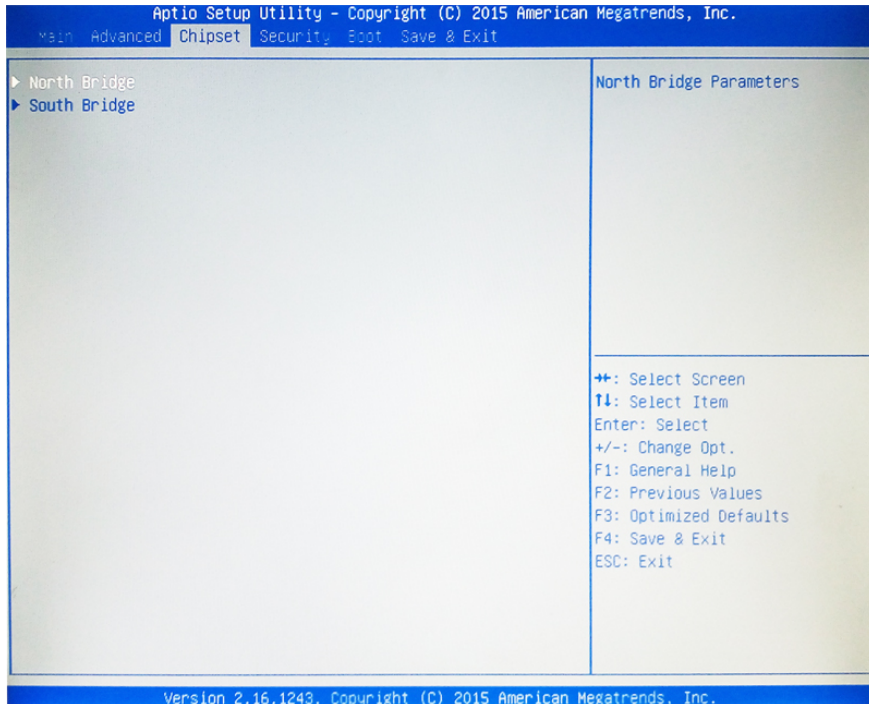

▶ **North Bridge**

Press [Enter] to make settings for the following sub-items:

PAVC

Use this item to enable or disable protected audio video control.

The optional settings are: [Disabled]; [LITE Mode]; [SERPENT Mode].

DVMT Pre-Allocated

Use this item to select DVMT 5.0 pre-allocated (fixed) graphics memory size used by the internal graphics device.

The optional settings are: [64M]; [96M]; [128M]; [160M]; [192M]; [224M]; [256M];

[288M]; [320M]; [352M]; [384M]; [416M]; [448M]; [480M]; [512M].

DVMT Total Gfx Mem

Use this item to select DVMT 5.0 total graphics memory size used by the internal graphics device.

The optional settings are: [128M]; [256M]; [MAX].

Aperture Size

The optional settings are: [128MB]; [256MB]; [512MB].

GTT Size

The optional settings are: [1MB]; [2MB].

Primary IGFX Boot Display

The optional settings are: [VBIOS Default]; [CRT(Dongle)]; [DVI];[LVDS].

Active LVDS

The optional settings are: [Disabled]; [Enabled].

[Disable]: VBIOS disable LVDS.

[Enable]: VBIOS enable LVDS.

* **Note:** When set as 'Enabled', user can make further settings in 'LVDS Panel Type'.

LVDS Panel Type

Use this item to manually select LVDS panel type.

The optional setting are: [800x 480 1ch 18-bit]; [800x 600 1ch18-bit]; [800x 600 1ch 24-bit]; [1024 x 600 1ch 18-bit]; [1024 x 768 1ch 18-bit]; [1024 x 768 1ch 24-bit]; [1280 x 768 1ch 24-bit]; [1280 x 800 1ch 18-bit]; [1280 x 800 24-bit]; [1366 x 768 1ch 18-bit]; [1366 x 768 1ch 24-bit]; [1440 x 900 2ch 18-bit]; [1440 x 900 2ch 24-bit]; [1280 x 1024 2ch 24-bit]; [1680 x 1050 2ch 24-bit]; [1920 x 1080 2ch 24-bit].

DVI to CRT Dongle Support

The optional settings are: [Disabled]; [Enabled].

▶ **South Bridge**

Press [Enter] to further setting USB device configuration.

ASMedia SATA Controller

The optional settings are: [Enabled]; [Disabled].

Mini PCIE

The optional settings are: [Enabled]; [Disabled].

Mini PCIE Speed

The optional settings are: [Auto]; [Gen2]; [Gen1].

PCIE Slot

The optional settings are: [Enabled]; [Disabled].

PCIE Slot Speed

The optional settings are: [Auto]; [Gen 2]; [Gen 1].

Onboard PCIE LAN

The optional settings are: [Enabled]; [Disabled].

Audio Controller

Use this item to control detection of the Azalia device.

The optional settings are: [Disabled]; [Enabled].

[Disabled]: Azalia will be unconditionally disabled;

[Enabled]: Azalia will be unconditionally enabled.

Azalia Internal HDMI Codec

Use this item to enable or disable internal HDMI codec for Azalia.

The optional settings are: [Disabled]; [Enabled].

▶ USB Configuration

Press [Enter] to make settings for the following sub-items:

USB Configuration

USB 3.0 Support

The optional settings are: [Auto]; [Enabled]; [Disabled].

USB 2.0 Support

The optional settings are: [Enable]; [Disabled].

**This item may or may not show up, depending on different configuration.*

System State after Power Failure

Use this item to select AC power state when power is re-applied after a power failure.

The optional settings are: [Always Off]; [Always On]; [Former State].

** The option [Always On] and [Former State] are affected by ERP function. Please*

disable ERP to support [Always On] and [Former State] function.

3-9 Security Menu

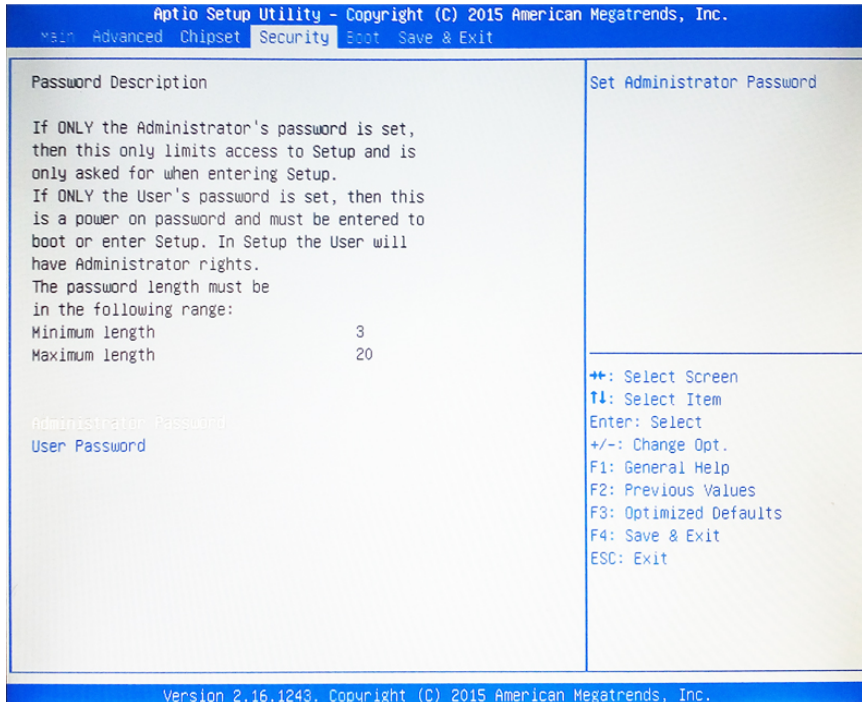

Security menu allow users to change administrator password and user password settings.

3-10 Boot Menu

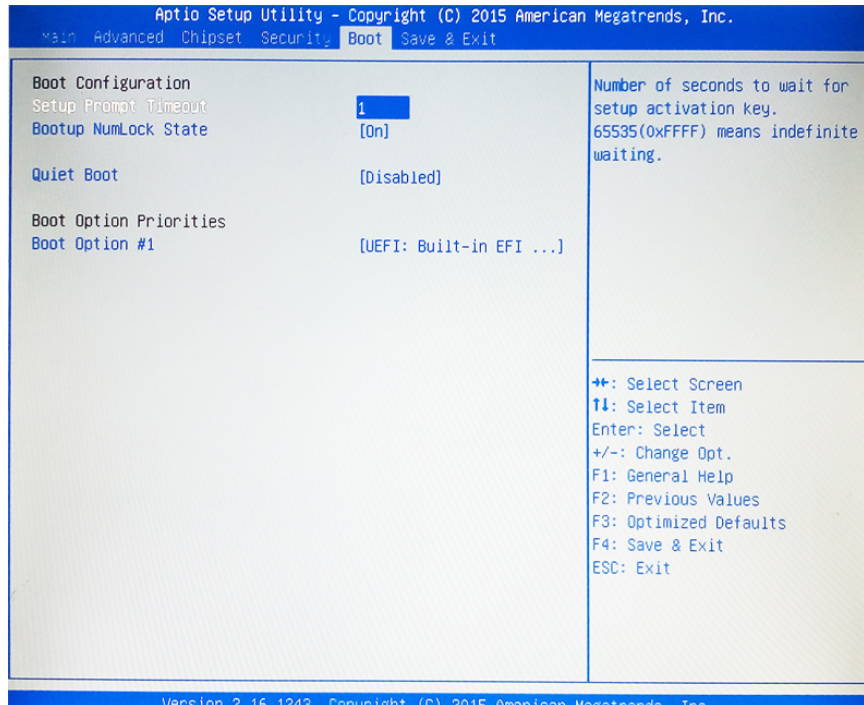

Boot Configuration

Setup Prompt Timeout

Use this item to set number of seconds to wait for setup activation key.

Bootup Numlock State

Use this item to select keyboard numlock state.

The optional settings are: [On]; [Off].

Quiet Boot

The optional settings are: [Disabled]; [Enabled].

Boot Option Priorities

Boot Option

The optional settings are: [UEFI: Built-in EFI Shell]; [Disabled].

3-11 Save & Exit Menu

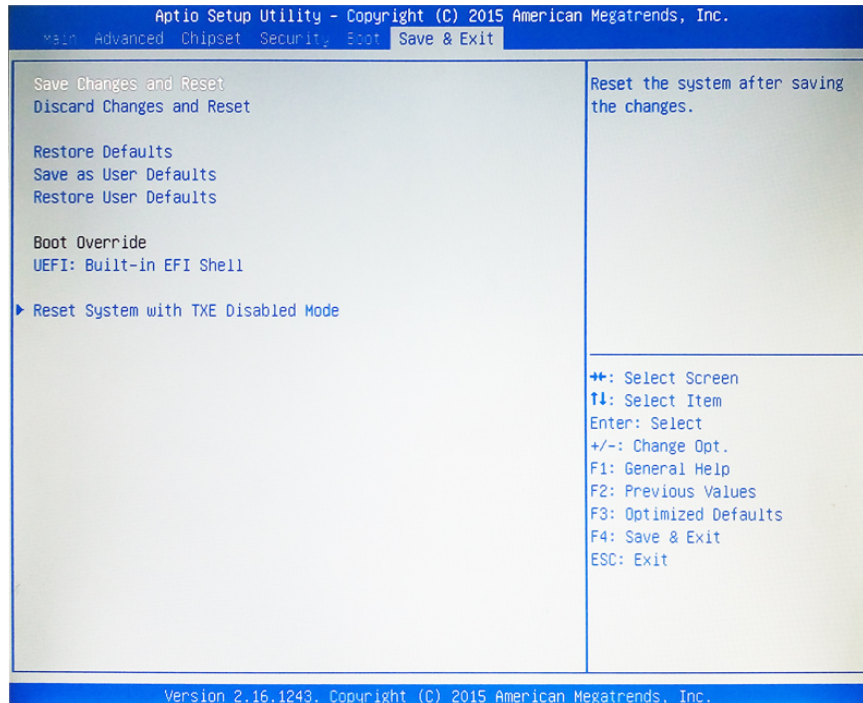

Save Changes and Reset

This item allows user to reset the system after saving the changes.

Discard Changes and Reset

This item allows user to reset the system without saving any changes.

Restore Defaults

Use this item to restore /load default values for all the setup options.

Save as User Defaults

Use this item to save the changes done so far as user defaults.

Restore User Defaults

Use this item to restore the user defaults to all the setup options.

Boot Override

Boot Override

UEFI: Built-in EFI Shell

Launch Internal EFI shell application (shell.efi).

Reset System with TXE disable Mode

Press [Enter] for TXE to run into the temporary disable mode. Ignore if TXE Ignition FM.