

Technical Manual
Of
Intel Apollo Lake Series CPU
Based SBC

NO.G03-NP691-F

Revision: 3.0

Release date: October 1, 2019

Trademark:

- * Specifications and Information contained in this documentation are furnished for information use only, and are subject to change at any time without notice, and should not be construed as a commitment by manufacturer.

Environmental Protection Announcement

Do not dispose this electronic device into the trash while discarding. To minimize pollution and ensure environment protection of mother earth, please recycle.



TABLE OF CONTENT

ENVIRONMENTAL SAFETY INSTRUCTION.....	iv
USER'S NOTICE	v
MANUAL REVISION INFORMATION	v
ITEM CHECKLIST	v
CHAPTER 1 INTRODUCTION OF THE MOTHERBOARD	
1-1 FEATURE OF MOTHERBOARD	1
1-2 SPECIFICATION	2
1-3 LAYOUT DIAGRAM	3
CHAPTER 2 HARDWARE INSTALLATION	
2-1 JUMPER SETTINGS.....	8
2-2 CONNECTORS AND HEADERS.....	12
2-2-1 CONNECTORS	12
2-2-2 HEADERS	14
CHAPTER 3 INTRODUCING BIOS	
3-1 ENTERING SETUP	20
3-2 BIOS MENU SCREEN	21
3-3 FUNCTION KEYS	21
3-4 GETTING HELP	22
3-5 MEMU BARS.....	22
3-6 MAIN MENU	23
3-7 ADVANCED MENU	24
3-8 CHIPSET MENU.....	34
3-9 SECURITY MENU	37
3-10 BOOT MENU	39
3-11 SAVE & EXIT MENU	40



Environmental Safety Instruction

- Avoid the dusty, humidity and temperature extremes. Do not place the product in any area where it may become wet.
- 0 to 60 centigrade is the suitable temperature. (The figure comes from the request of the main chipset)
- Generally speaking, dramatic changes in temperature may lead to contact malfunction and crackles due to constant thermal expansion and contraction from the 'welding spots' that connect components and PCB. Computer should go through an adaptive phase before it boots when it is moved from a cold environment to a warmer one to avoid condensation phenomenon. These water drops attached on PCB or the surface of the components can bring about phenomena as minor as computer instability resulted from corrosion and oxidation from components and PCB or as major as short circuit that can burn the components. Suggest starting the computer until the temperature goes up.
- The increasing temperature of the capacitor may decrease the life of computer. Using the close case may decrease the life of other device because the higher temperature in the inner of the case.
- Attention to the heat sink when you over-clocking. The higher temperature may decrease the life of the device and burned the capacitor.

USER'S NOTICE

COPYRIGHT OF THIS MANUAL BELONGS TO THE MANUFACTURER. NO PART OF THIS MANUAL, INCLUDING THE PRODUCTS AND SOFTWARE DESCRIBED IN IT MAY BE REPRODUCED, TRANSMITTED OR TRANSLATED INTO ANY LANGUAGE IN ANY FORM OR BY ANY MEANS WITHOUT WRITTEN PERMISSION OF THE MANUFACTURER.

THIS MANUAL CONTAINS ALL INFORMATION REQUIRED TO USE THIS MOTHER-BOARD SERIES AND WE DO ASSURE THIS MANUAL MEETS USER'S REQUIREMENT BUT WILL CHANGE, CORRECT ANY TIME WITHOUT NOTICE. MANUFACTURER PROVIDES THIS MANUAL "AS IS" WITHOUT WARRANTY OF ANY KIND, AND WILL NOT BE LIABLE FOR ANY INDIRECT, SPECIAL, INCIDENTAL OR CONSEQUENTIAL DAMAGES (INCLUDING DAMAGES FOR LOSS OF PROFIT, LOSS OF BUSINESS, LOSS OF USE OF DATA, INTERRUPTION OF BUSINESS AND THE LIKE).

PRODUCTS AND CORPORATE NAMES APPEARING IN THIS MANUAL MAY OR MAY NOT BE REGISTERED TRADEMARKS OR COPYRIGHTS OF THEIR RESPECTIVE COMPANIES, AND THEY ARE USED ONLY FOR IDENTIFICATION OR EXPLANATION AND TO THE OWNER'S BENEFIT, WITHOUT INTENT TO INFRINGE.

Manual Revision Information

Reversion	Revision History	Date
3.0	Third Edition	October 1, 2019

Item Checklist

- Motherboard
- Cable(s)

Chapter 1

Introduction of the Motherboard

1-1 Feature of Motherboard

- Onboard Intel® Apollo Lake Series Processor, with low power consumption and high performance
- Support 1* DDR3L 1866 MHz SO-DIMM, up to 8GB
- 1* HDMI port & 1* LVDS, supports dual independent display
- Onboard 1* full-size Mini-PCIE slot & 1* SIM card slot
- Onboard 1* SATAIII port & 1* M.2 Socket 3 slot for M-Key type 2242 SATA SSD
- Support RJ-45 gigabit Ethernet LAN port
- Support USB 3.0 data transport demand
- Compliance with ErP standard
- Support Watchdog function
- Solution for IoT, Machine Control & Intelligent Home

1-2 Specification

Spec	Description
Design	<ul style="list-style-type: none">● 8-layer 2.5" SBC, Pico-size form factor; PCB size: 10 cm x 7.2 cm
Embedded CPU	<ul style="list-style-type: none">● Intel® Apollo Lake series CPU <i>* for detailed CPU support information please visit our website</i>
Memory Slot	<ul style="list-style-type: none">● 1*DDR3L SO-DIMM slot● Support DDR3L 1866 MHz SO-DIMM up to 8GB
Expansion Slot	<ul style="list-style-type: none">● 1* full-size Mini-PCIE slot (MPE)● 1* SIM card slot (SIMCARDB1)
Storage	<ul style="list-style-type: none">● 1* SATAIII 6Gb/s port● 1* M.2 Socket 3 slot (M2, M-key, support type-2242 SATA SSD)
LAN Chip	<ul style="list-style-type: none">● Integrated with Realtek 8111H Gigabit LAN chip● Support Fast Ethernet LAN function of providing 10/100/1000Mbps Ethernet data transfer rate
Audio Chip	<ul style="list-style-type: none">● Realtek ALC662VD HD audio chip
BIOS	<ul style="list-style-type: none">● AMI Flash ROM
Rear Panel I/O	<ul style="list-style-type: none">● 1* 12V DC-in power connector● 2* USB 3.0 port● 1* HDMI port● 1* RJ-45 LAN port
Internal I/O	<ul style="list-style-type: none">● 1* SATA Power-out connector● 1* JW_FP header● 1* 9-Pin USB 2.0/1.1 header for 2* USB 2.0/1.1 ports● 1* SMBUS header● 1* Buzzer header● 1* RS232/422/485 serial port (COM1)● 1* RS232 serial port (COM2)● 1* Front panel audio header● 1* GPIO header● 1* LVDS header● 1* LVDS inverter header

1-3 Layout Diagram

IO Panel Diagram:

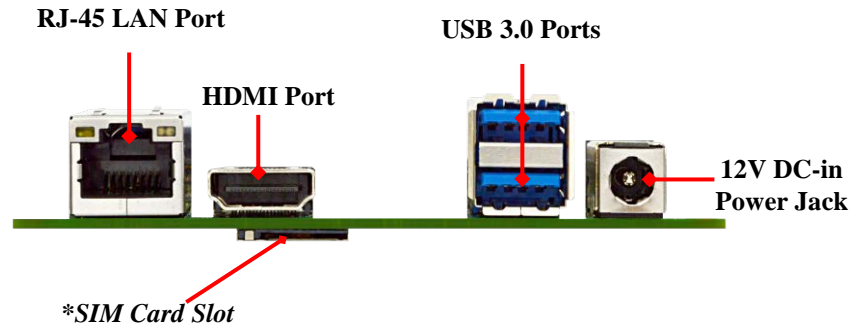

Note: *SIM card slot* is on the back side of the board and only works **when** compatible SIM card installed & 3G LAN card installed in full-size Mini-PCIE (**MPE**) slot.

Internal Diagram-Front Side:

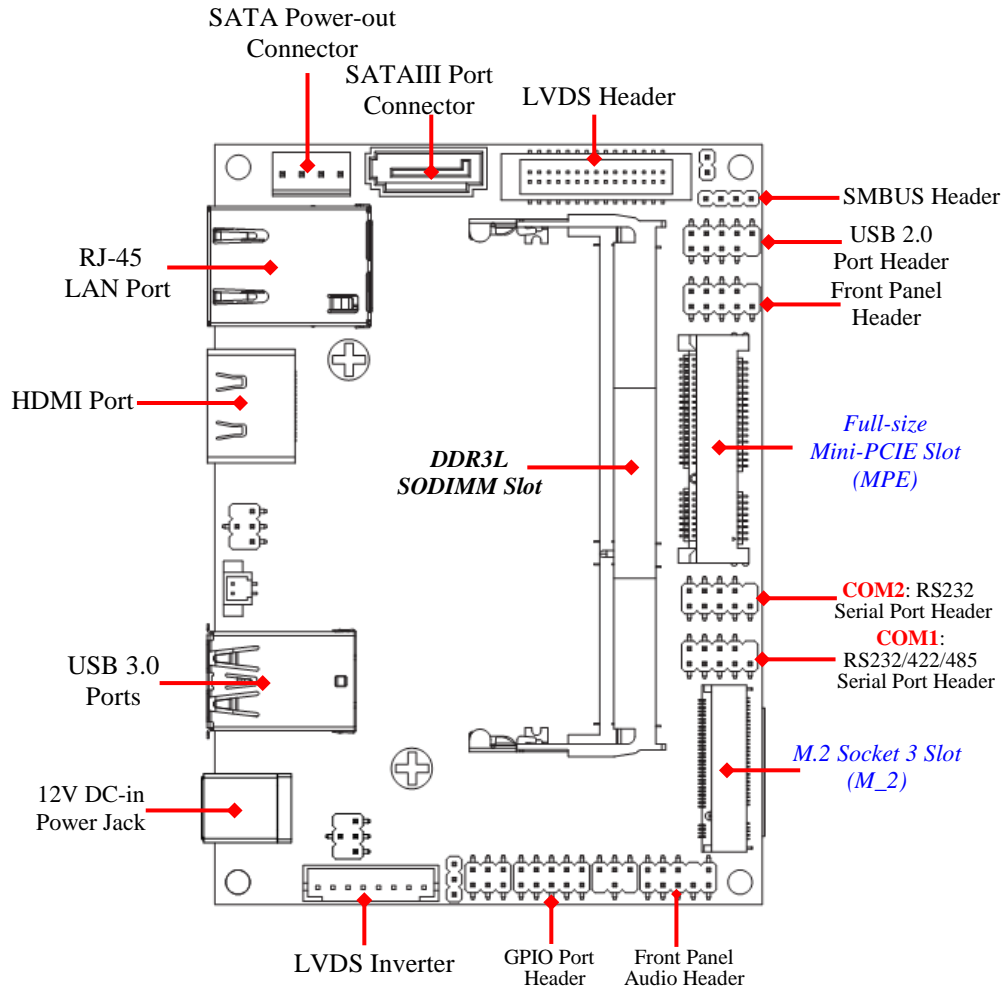

- Note:** 1. SODIMM module should be **1.35V DDRIII SODIMM** and **not exceeding 8GB total capacity**.
2. **SIM card slot** only work **when** compatible SIM card installed & 3G LAN card installed in full-size Mini-PCIE (MPE) slot.

Internal Diagram-Back Side:

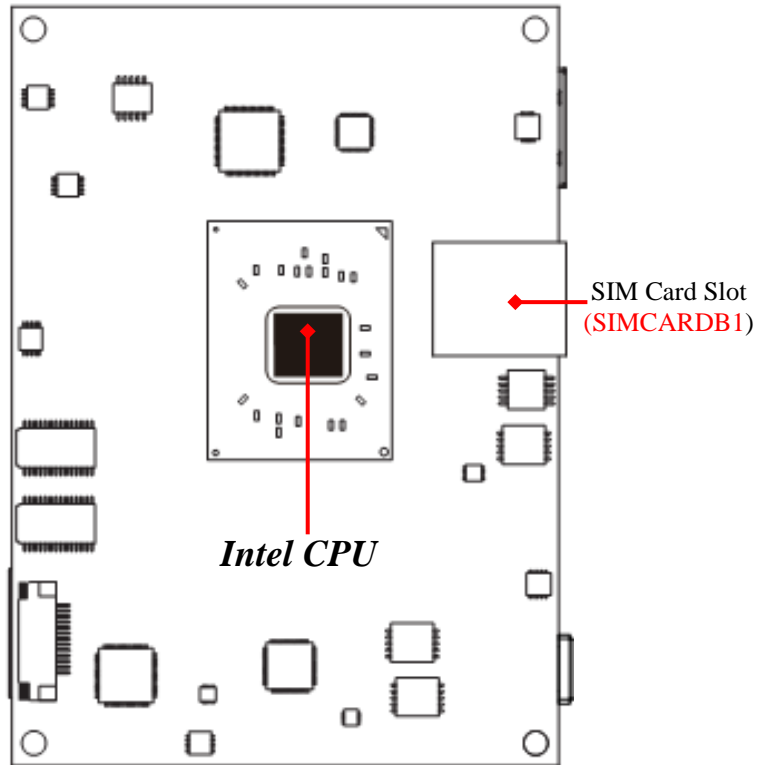

- Note:** 1. SODIMM module should be 1.35V DDRIII SODIMM and **not exceeding 8GB total capacity**.
2. **SIM card slot** only work **when** compatible SIM card installed & 3G LAN card installed in full-size Mini-PCIE (MPE) slot.

Motherboard Jumper Positions:

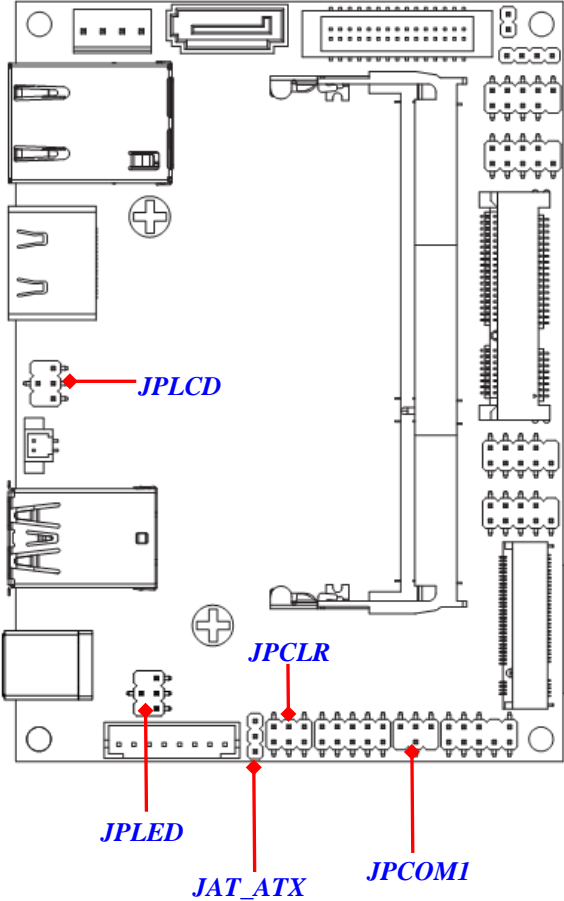

Jumper

Jumper	Name	Description
JPCLR	<i>Pin (1-2):</i> Clear CMOS RAM Settings <i>Pin (3-4):</i> RTC Reset for clear Flash <i>Pin (5-6):</i> TXE Override	6-Pin Block
JAT_ATX	ATX/AT Mode Select	3-Pin Block
JPCOM1	COM1 Port Pin9 Function Select	4-Pin Block
JPLCD	LVDS Panel VCC Select	4-Pin Block
JPLED	LVDS LED VCC Select	4-Pin Block

Connectors

Connector	Name
DCIN1	12V DC-in System Power Jack
USB1	USB 3.0 Port Connector x2
HDMI	HDMI Port Connector
LAN1	RJ-45 LAN Port Connector
SATA	SATAIII Port Connector
PWROUT	SATA Power out Connector

Headers

Header	Name	Description
FP	Front Panel Header(PWR LED/ HD LED/Power Button /Reset)	9-pin Block
USB3	USB2.0 Port Header	9-pin Block
SMBUS	SMBUS Header	4-pin Block
BUZZ	Buzzer Header	2-pin Block
COM1	RS232/422/485 Serial Port Header	9-pin Block
COM2	RS232 Serial Port Header	9-pin Block
FP_AUDIO	Front Panel Audio Header	9-pin Block
GPIO	GPIO Port Header	10-pin Block
LVDS	LVDS Port Header	30-pin Block
INVERTER	LVDS Inverter Header	8-pin Block

Chapter 2 Hardware Installation

2-1 Jumper Settings

Pin 1&2 of JPCLR(6-pin): Clear CMOS RAM Settings

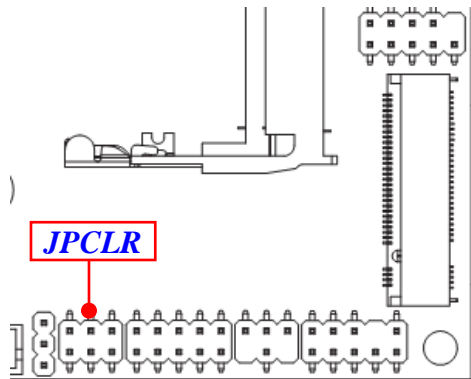

Pin (1&2) of JPCLR → Clear CMOS

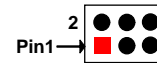

1-2 Open: Normal(Default);

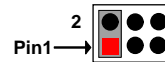

1-2 Closed: Clear CMOS(One Touch).

Pin 3&4 of JPCLR (6-pin): RTC Reset for Clear Flash

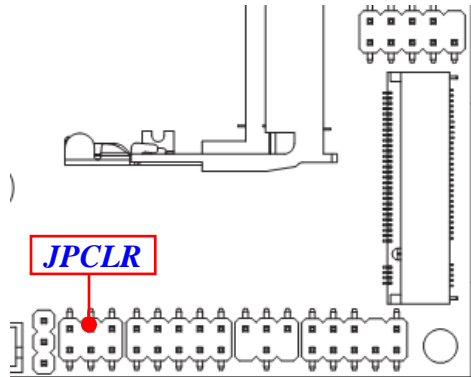

**Pin (3&4) of JPCLR →
Reset RTC for Clear Flash**

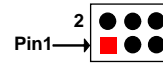

3-4 Open: Normal;

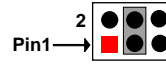

3-4 Closed: Reset RTC.

Pin 5&6 of JPCLR (6-pin): Flash Deacriptors Override Select

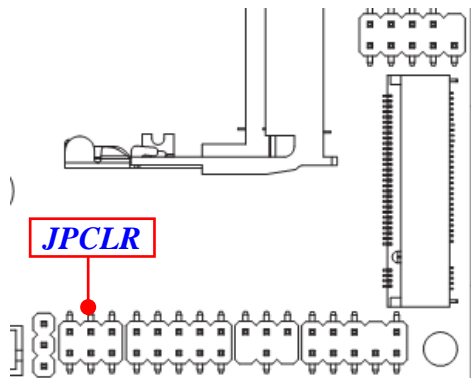

Pin (5&6) of JPCLR → Flash Override

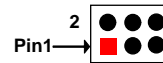

5-6 Open: Enable Security Measures
in the Flash Descriptor(Default);

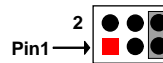

5-6 Closed: Disable Security Measures
in the Flash Descriptor(Override).

JAT_ATX (3-pin): AT Mode /ATX Mode Select

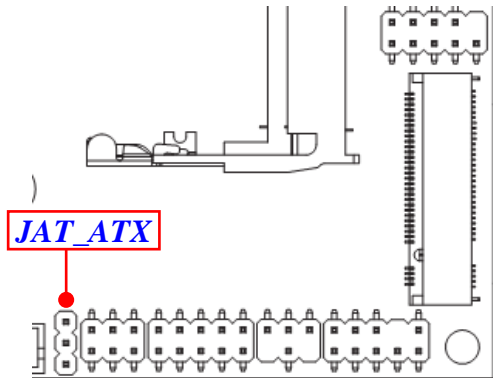

JAT_ATX → ATX/AT Mode Select

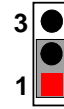

1-2 Closed: ATX Mode Selected;

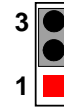

2-3 Closed: AT Mode Selected.

***ATX Mode Selected:** Press power button to power on after power input ready;
AT Mode Selected: Directly power on as power input ready.

JPCOM1 (4-pin): COM1 Header Pin9 Function Select

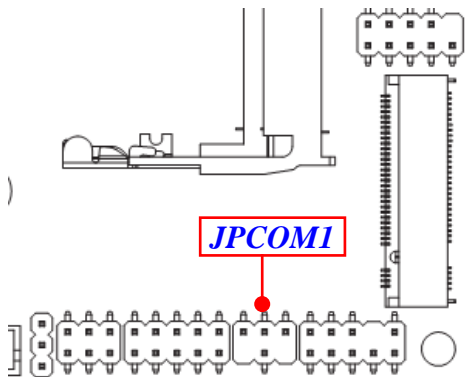

JPCOM1 → COM1 Header Pin-9

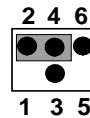

2-4 Closed:
Pin9=RS232;

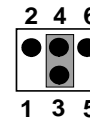

3-4 Closed:
Pin9 = 5V;

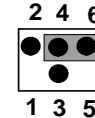

4-6 Closed:
Pin9 = 12V.

JPLED (4-pin): LVDS Panel Inverter Backlight LED VCC Select

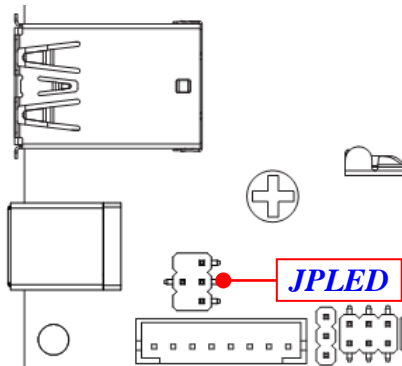

JPLED→LVDS Panel Backlight VCC

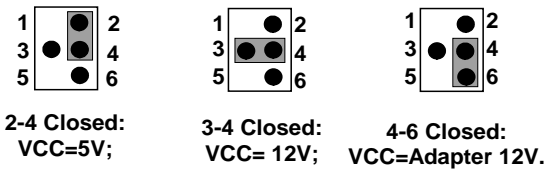

JPLCD (4-pin): LVDS Panel VCC 3.3V/5V/12V Select

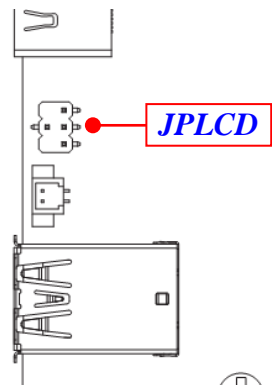

JPLCD→LVDS Panel VCC

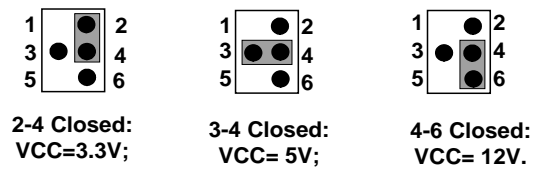



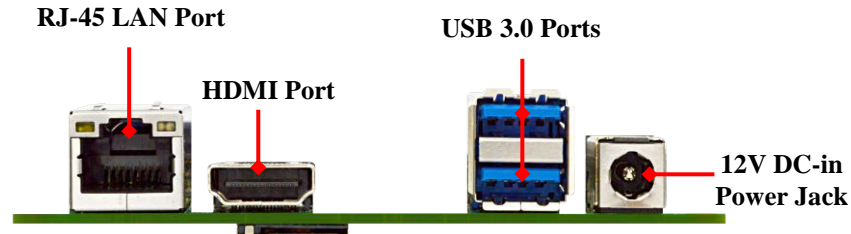

2-2 Connectors and Headers

2-2-1 Connectors

(1) Rear Panel Connectors



Icon	Name	Function
	RJ-45 LAN Port	This connector is standard RJ-45 LAN jack for Network connection.
	HDMI Port	To connect display device that support HDMI specification.
	USB 3.0 Port	To connect USB keyboard, mouse or other devices compatible with USB specification. USB 3.0 ports supports up to 5Gbps data transfer rate.
	Power Connector	12V DC–in system power connector For user to connect compatible power adapter to provide power supply for the system.

(2) SATA (7-pin Block): SATAIII Port connector

The board comes with a SATAIII port that supports 6GB/s transfer rate.

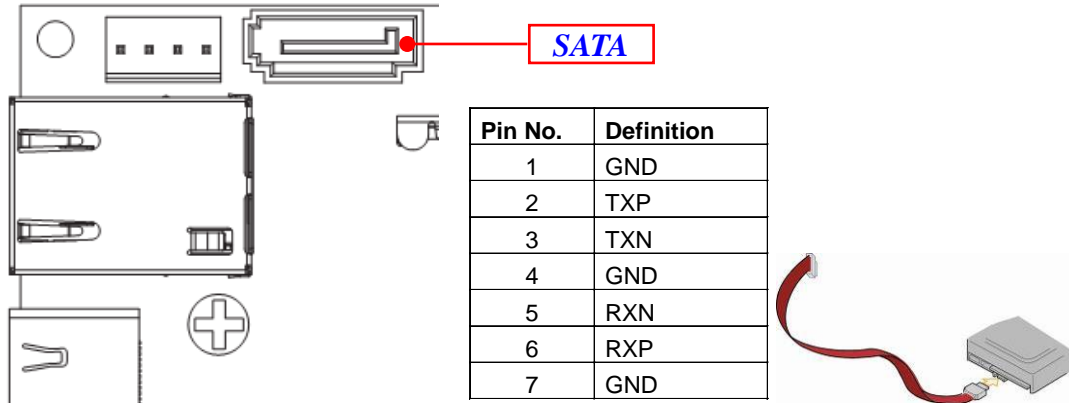

(3) PWROUT (4-pin): SATA HDD Power-Out Connector

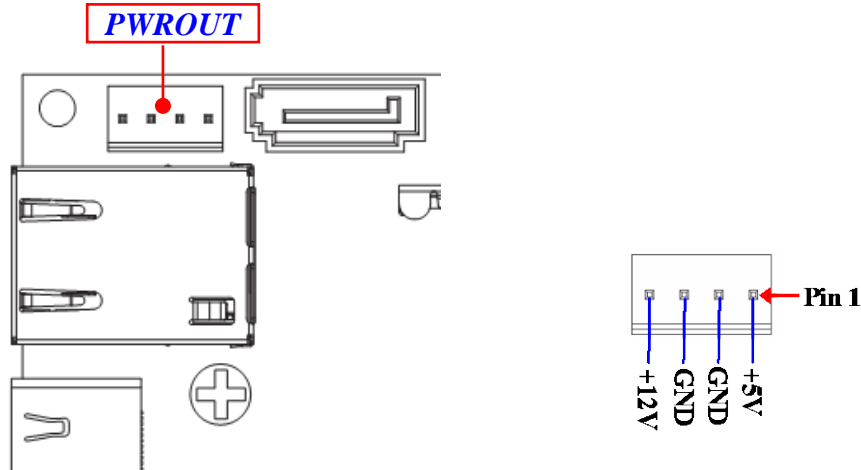

Warning: Make sure that Pin-1 of compatible SATA Power connector is inserted into corresponding Pin-1 of PWROUT connector to avoid possible damage to the board and hard disk driver!

2-2-2 Headers

FP (9-pin): Front Panel Header

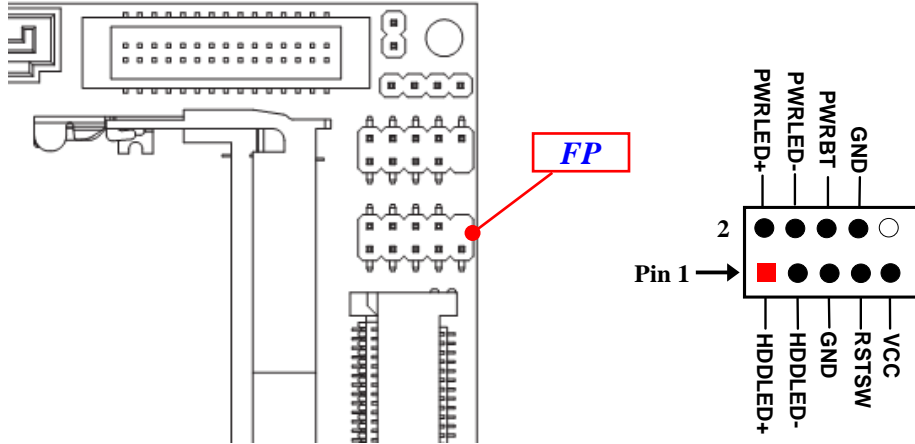

USB3 (9-pin): USB 2.0 Port Header

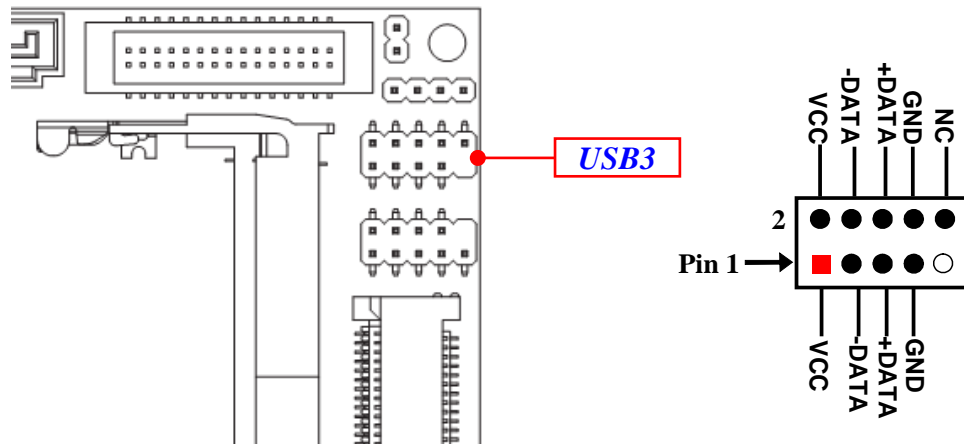

SMBUS (4-Pin): SMBUS Header

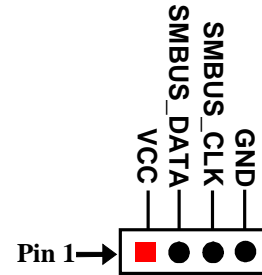
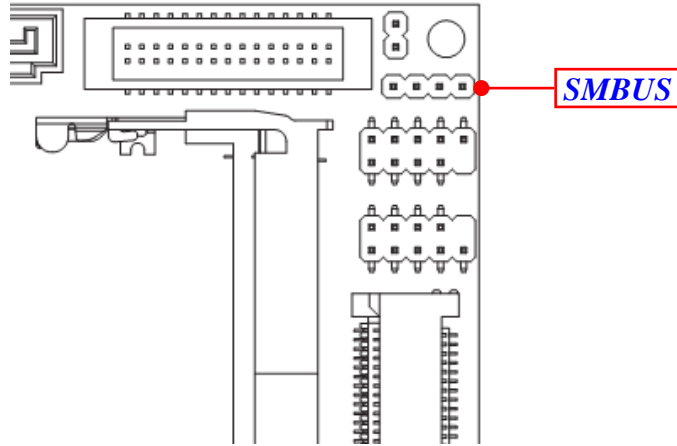

BUZZ (2-pin): Buzzer Header

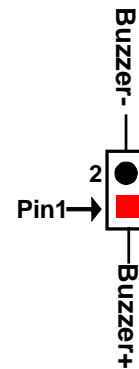
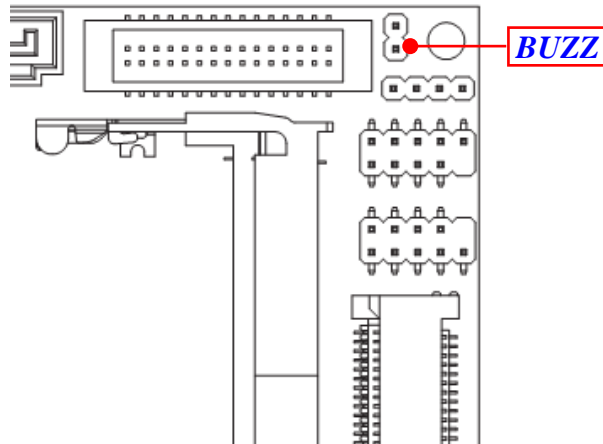

COM1/2 (9-pin): Serial Port Headers

COM1: RS232/422/485 Serial Port Header;

COM2: RS232 Serial Port Header.

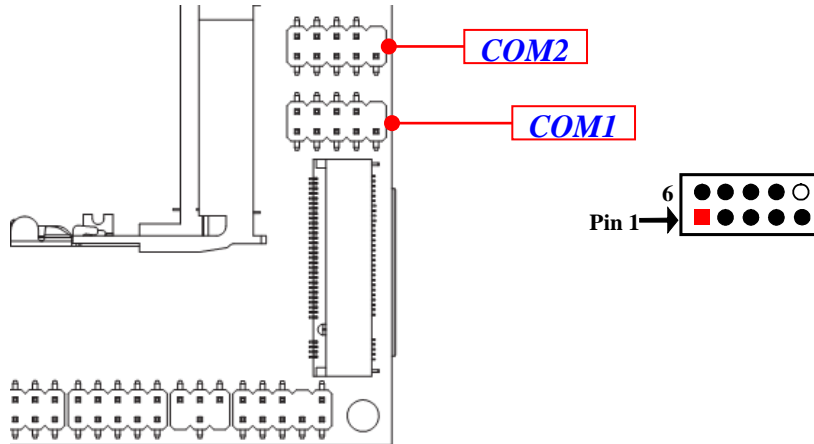

Pin NO.	RS232	*RS422	*RS485
Pin 1	DCD	TX-	DATA-
Pin 2	RXD	TX+	DATA+
Pin 3	TXD	RX+	NC
Pin 4	DTR	RX-	NC
Pin 5	GND	GND	GND
Pin 6	DSR	NC	NC
Pin 7	RTS	NC	NC
Pin 8	CTS	NC	NC
Pin 9	RI	NC	NC

***Notice:** RS422, RS485 function is supported by COM1 header only, with compatible COM cable for RS422 or RS 485 function. User also needs to go to BIOS to set 'Transmission Mode Select' for COM1 (refer to Page 25).

FP_AUDIO (9-pin): Line-Out, MIC-In Header

This header connects to Front Panel Line-out, MIC-In connector with cable.

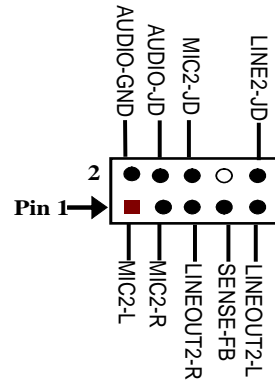
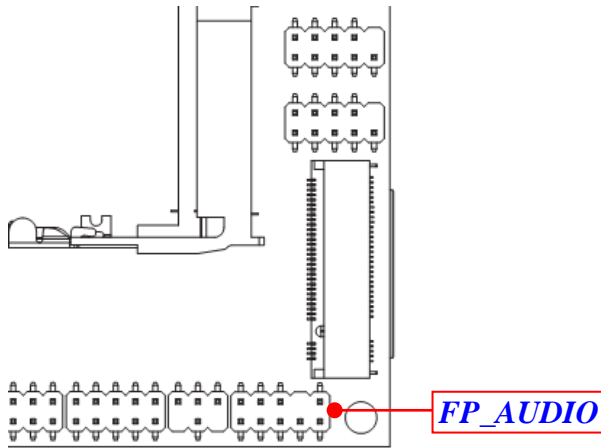

GPIO (10-pin): GPIO Port Header

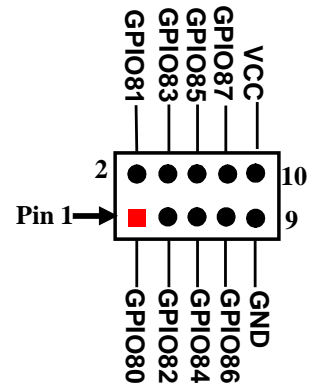
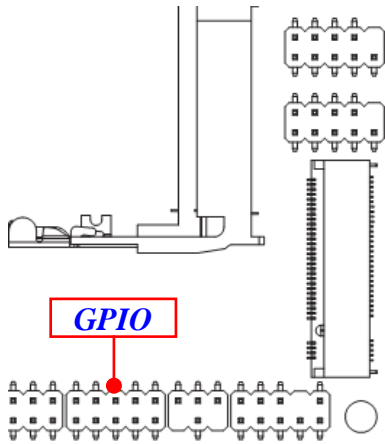

LVDS (30-pin): 24-bit Dual Channel LVDS Header

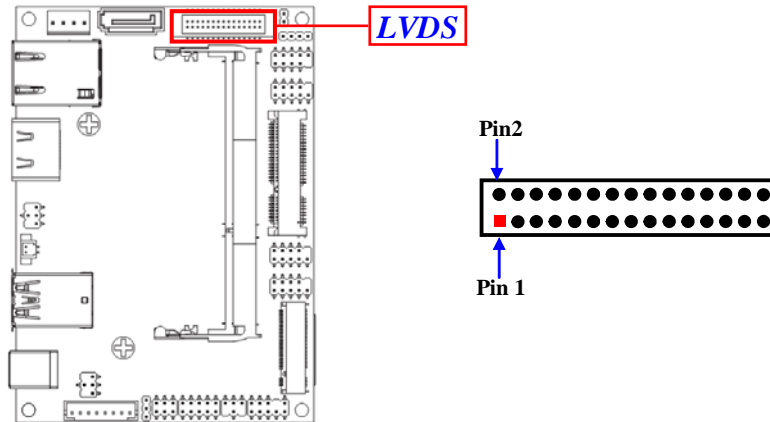

Pin NO.	Pin Define	Pin NO.	Pin Define
Pin 1	LVDSB_DATAN3	Pin 2	LVDSB_DATAP3
Pin 3	LVDS_CLKBN	Pin 4	LVDS_CLKBP
Pin 5	LVDSB_DATAN2	Pin 6	LVDSB_DATAP2
Pin 7	LVDSB_DATAN1	Pin 8	LVDSB_DATAP1
Pin 9	LVDSB_DATAN0	Pin 10	LVDSB_DATAP0
Pin 11	NC/DDC_DATA	Pin 12	NC/DDC_CLK
Pin 13	GND	Pin 14	GND
Pin 15	GND	Pin 16	GND
Pin 17	LVDSA_DATAP3	Pin 18	LVDSA_DATAN3
Pin 19	LVDS_CLKAP	Pin 20	LVDS_CLKAN
Pin 21	LVDSA_DATAP2	Pin 22	LVDSA_DATAN2
Pin 23	LVDSA_DATAP1	Pin 24	LVDSA_DATAN1
Pin 25	LVDSA_DATAP0	Pin 26	LVDSA_DATAN0
Pin 27	LCD VCC	Pin 28	LCD VCC
Pin 29	LCD VCC	Pin 30	LCD VCC

INVERTER (8-pin): LVDS Inverter Connector

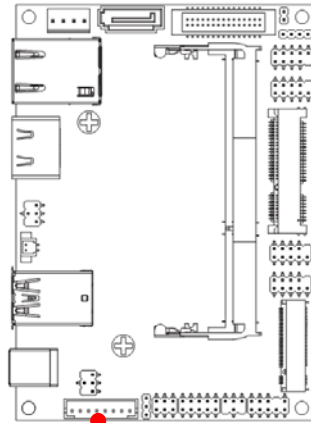

INVERTER

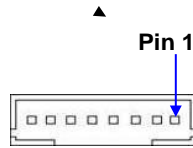

Pin No.	Definition
1	Backlight Enable
2	Backlight PWM
3	Back Light LED VCC
4	Back Light LED VCC
5	GND
6	GND
7	Backlight Up SW
8	Backlight Down SW

Chapter 3

Introducing BIOS

Notice! The BIOS options in this manual are for reference only. Different configurations may lead to difference in BIOS screen and BIOS screens in manuals are usually the first BIOS version when the board is released and may be different from your purchased motherboard. Users are welcome to download the latest BIOS version form our official website.

The BIOS is a program located on a Flash Memory on the motherboard. This program is a bridge between motherboard and operating system. When you start the computer, the BIOS program will gain control. The BIOS first operates an auto-diagnostic test called POST (power on self test) for all the necessary hardware, it detects the entire hardware device and configures the parameters of the hardware synchronization. Only when these tasks are completed done it gives up control of the computer to operating system (OS). Since the BIOS is the only channel for hardware and software to communicate, it is the key factor for system stability, and in ensuring that your system performance as its best.

3-1 Entering Setup

Power on the computer and by pressing immediately allows you to enter Setup. If the message disappears before your respond and you still wish to enter Setup, restart the system to try again by turning it OFF then ON or pressing the “RESET” button on the system case. You may also restart by simultaneously pressing <Ctrl>, <Alt> and <Delete> keys. If you do not press the keys at the correct time and the system does not boot, an error message will be displayed and you will again be asked to

Press to enter Setup/ Press <F7> to enter Popup Menu.

3-2 BIOS Menu Screen

The following diagram show a general BIOS menu screen:

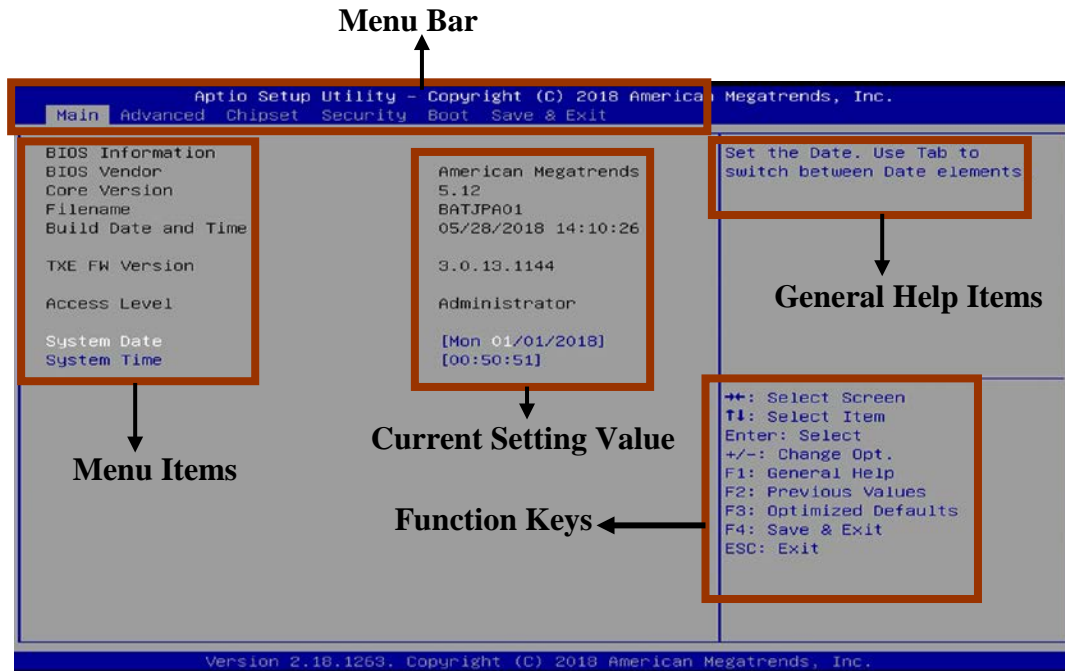

3-3 Function Keys

In the above BIOS Setup main menu of, you can see several options. We will explain these options step by step in the following pages of this chapter, but let us first see a short description of the function keys you may use here:

- Press ←→ (left, right) to select screen;
- Press ↑↓ (up, down) to choose, in the main menu, the option you want to confirm or to modify.
- Press <Enter> to select.

-
-
- Press <+>/<-> keys when you want to modify the BIOS parameters for the active option.
 - [F1]: General help.
 - [F2]: Previous value.
 - [F3]: Optimized defaults.
 - [F4]: Save & Exit.
 - Press <Esc> to quit the BIOS Setup.

3-4 Getting Help

Main Menu

The on-line description of the highlighted setup function is displayed at the top right corner the screen.

Status Page Setup Menu/Option Page Setup Menu

Press [F1] to pop up a small help window that describes the appropriate keys to use and the possible selections for the highlighted item. To exit the Help Window, press <Esc>.

3-5 Menu Bars

There are six menu bars on top of BIOS screen:

Main	To change system basic configuration
Advanced	To change system advanced configuration
Chipset	To change chipset configuration
Security	Password settings
Boot	To change boot settings
Save & Exit	Save setting, loading and exit options.

User can press the right or left arrow key on the keyboard to switch from menu bar. The selected one is highlighted.

3-6 Main Menu

Main menu screen includes some basic system information. Highlight the item and then use the <+> or <-> and numerical keyboard keys to select the value you want in each item.

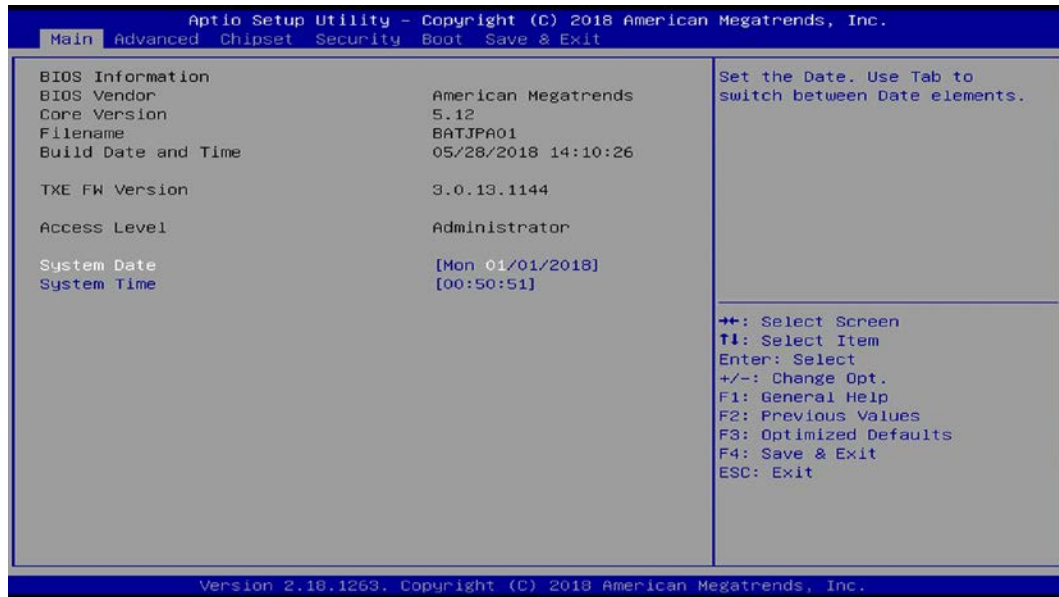

System Date

Set the date. Please use [Tab] to switch between data elements.

System Time

Set the time. Please use [Tab] to switch between time elements.

3-7 Advanced Menu

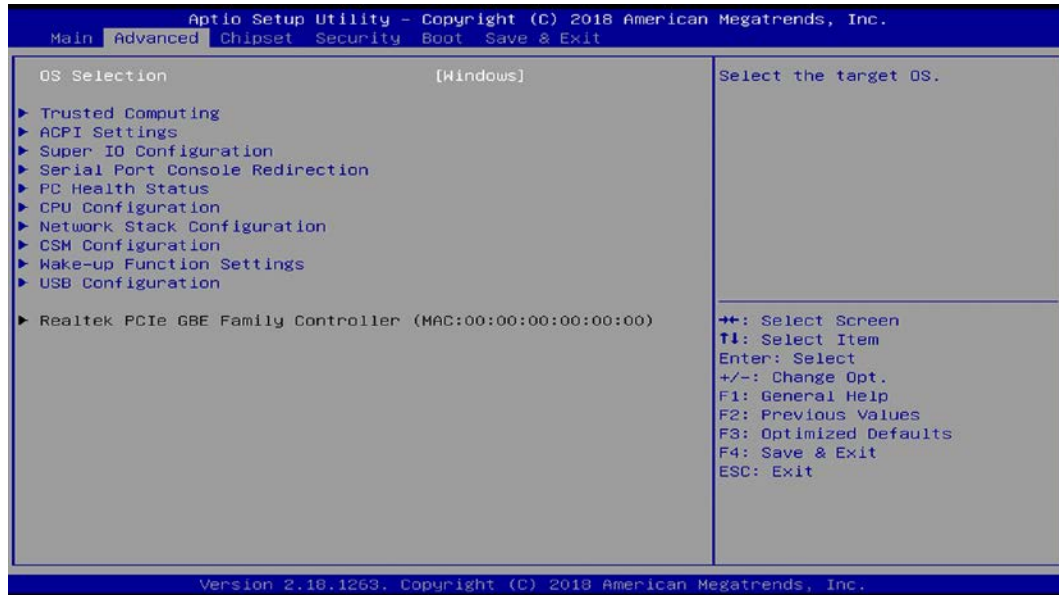

OS Selection

The optional settings: [Windows]; [Intel Linux]; [MSDOS].

* **Note:** User need to go to this item to select the OS mode before installing corresponding OS driver, otherwise problems will occur when installing the driver.

▶ Trusted Computing

Press [Enter] to enable or disable 'Security Device Support'.

TPM20 Device Found

Security Device Support

Use this item to enable or disable BIOS support for security device.

The optional settings: [Disabled]; [Enabled].

Active PCR Banks

The optional setting is: [SHA-1].

Available PCR Banks

The optional setting is: [SHA-1, SHA256].

SHA-1 PCR Bank

Use this item to enable or disable SHA-1 PCR Bank.

The optional settings: [Disabled]; [Enabled].

SHA256 PCR Bank

Use this item to enable or disable SHA256 PCR Bank.

The optional settings: [Disabled]; [Enabled].

▶ **ACPI Settings**

Press [Enter] to make settings for the following sub-items:

ACPI Settings

ACPI Sleep State

Use this item to select the highest ACPI sleep state the system will enter when the suspend button is pressed.

The optional settings are: [Suspend Disabled]; [S3 (Suspend to RAM)].

▶ **Super I/O Configuration**

Press [Enter] to make settings for the following sub-items:

Super IO Configuration

▶ **Serial Port 1 Configuration**

Press [Enter] to make settings for the following items:

Serial Port 1 Configuration

Serial Port

Use this item to enable or disable serial port (COM).

The optional settings are: [Disabled]; [Enabled].

Change Settings

Use this item to select an optimal setting for super IO device. **Changing setting may conflict with system resources.**

The optional settings are: [Auto]; [IO=3F8h; IRQ=4]; [IO=2F8h; IRQ=3]; [IO=3E8h; IRQ=4] ; [IO=2E8h; IRQ=3].

Transmission Mode Select

The optional settings are: [RS422]; [RS232]; [RS485].

Mode Speed Select

The optional settings are: [RS232/RS422/RS485=250kbps]; [RS232=1Mbps, RS422/RS485=10Mbps].

▶ **Serial Port 2 Configuration**

Press [Enter] to make settings for the following items:

Serial Port 2 Configuration

Serial Port

Use this item to enable or disable serial port (COM).

The optional settings are: [Disabled]; [Enabled].

Change Settings

Use this item to select an optimal setting for super IO device. **Changing setting may conflict with system resources.**

The optional settings are: [Auto]; [IO=3F8h; IRQ=4]; [IO=2F8h; IRQ=3]; [IO=3E8h; IRQ=4]; [IO=2E8h; IRQ=3].

ERP Support

The optional settings are: [Disabled]; [Enabled].

This item should be set as [**Disabled**] if you wish to have all active wake-up functions.

WatchDog Reset Timer

Use this item to enable or disable WDT reset function. When set as [Enabled], the following sub-items shall appear:

WatchDog Reset Timer Value

User can set a value in the range of [10] to [255].

WatchDog Reset Timer Unit

The optional settings are: [Sec.]; [Min.].

WatchDog Wake-up Timer

This item support WDT wake-up.

The optional settings are: [Enabled]; [Disabled].

When set as [Enabled], the following sub-items shall appear:

WatchDog Wake-up Timer Value

User can select a value in the range of [10] to [4095] seconds when '**WatchDog Wake-up Timer Unit**' set as [Sec.]; or in the range of [1] to [4095] minutes when '**WatchDog Wake-up Timer Unit**' set as [Min].

WatchDog Wake-up Timer Unit

The optional settings are: [Sec.]; [Min.].

ATX Power Emulate AT Power

This item support Emulate AT power function, MB power On/Off control by power supply. Use needs to select 'AT or ATX Mode' on MB jumper at first (refer to **Page 9**, Pin 1-2 of AT_COPEN block for ATX Mode & AT Mode Select).

▶ **Serial Port Console Redirection**

COM1

Console Redirection

The optional settings: [Disabled]; [Enabled]. When set as [Enabled], the following sub-items shall appear:

▶ **Console Redirection Settings**

The settings specify how the host computer and the remote computer (which the user is using) will exchange data. Both computers should have the same or compatible settings.

Press [Enter] to make settings for the following items:

Terminal Type

The optional settings: [VT100]; [VT100+]; [VT-UTF8]; [ANSI].

Emulation: [ANSI]: Extended ASCII char set; [VT100]: ASCII char set; [VT100+]: Extends VT100 to support color, function keys, etc.; [VT-UTF8]: Uses UTF8 encoding to map Unicode chars onto 1 or more bytes.

Bits per second

Use this item to select serial port transmission speed. The speed must be matched on the other side. Long or noisy lines may require lower speeds.

The optional settings: [9600]; [19200]; [38400]; [57600]; [115200].

Data Bits

The optional settings: [7]; [8].

Parity

A parity bit can be sent with the data bits to detect some transmission errors.

The optional settings: [None]; [Even]; [Odd]; [Mark]; [Space].

[Even]: parity bit is 0 if the num of 1's in the data bits is even; [Odd]: parity bit is 0 if num of 1's in the data bits is odd; [Mark]: parity bit is always 1; [Space]: Parity bit is always 0; [Mark] and [Space] Parity do not allow for error detection.

Stop Bits

Stop bits indicate the end of a serial data packet. (A start bit indicates the beginning). The standard setting is 1 stop bit. Communication with slow devices may require more than 1 stop bit.

The optional settings: [1]; [2].

Flow Control

Flow control can prevent data loss from buffer overflow. When sending data, if the receiving buffers are full, a "stop" signal can be sent to stop the data flow. Once the buffers are empty, a "start" signal can be sent to re-start the flow. Hardware flow control uses two wires to send start/stop signals.

The optional settings: [None]; [Hardware RTS/CTS].

VT-UTF8 Combo Key Support

Use this item to enable VT-UTF8 Combination Key Support for ANSI/VT100 terminals.

The optional settings: [Disabled]; [Enabled].

Recorder Mode

With this mode enable only text will be sent. This is to capture Terminal data.

The optional settings: [Disabled]; [Enabled].

Resolution 100x31

Use this item to enable or disable extended terminal resolution.

The optional settings: [Disabled]; [Enabled].

Legacy OS Redirection Resolution

On Legacy OS, the Number of Rows and Columns supported redirection.

The optional settings: [80x24]; [80x25].

Putty KeyPad

Use this item to select FunctionKey and KeyPad on Putty.

The optional settings: [VT100]; [Intel Linux]; [XTERMR6]; [SCO]; [ESCN]; [VT400].

Redirection After BIOS POST

The optional settings are: [Always Enable]; [BootLoader].

When [Bootloader] is selected, then Legacy Console Redirection is disabled before booting to legacy OS. When [Always Enable] is selected, then Legacy Console is enabled for legacy OS. Default setting for this option is set to [Always Enable].

Serial Port for Out-of-Band Management/

Windows Emergency Management Services (EMS)

Console Redirection

The optional settings: [Disabled]; [Enabled]. When set as [Enabled], the following sub-items shall appear:

▶ Console Redirection Settings

The settings specify how the host computer and the remote computer (which the user is using) will exchange data. Both computers should have the same or compatible settings.

Press [Enter] to make settings for the following items:

Out-of-Band Mgmt Port

The optional setting is: [COM1].

Terminal Type

The optional settings: [VT100]; [VT100+]; [VT-UTF8]; [ANSI].

[VT-UTF8] is the preferred terminal type for out-of-band management. The next best choice is [VT100+] and then [VT100]. See above, in Console Redirection Settings page, for more help with Terminal Type/Emulation.

Bits per second

Use this item to select serial port transmission speed. The speed must be matched on the other side. Long or noisy lines may require lower speeds.

The optional settings: [9600]; [19200]; [57600]; [115200].

Flow Control

Flow control can prevent data loss from buffer overflow. When sending data, if the receiving buffers are full, a “stop” signal can be sent to stop the data flow. Once the buffers are empty, a “start” signal can be sent to re-start the flow. Hardware flow control uses two wires to send start/stop signals.

The optional settings: [None]; [Hardware RTS/CTS]; [Software Xon/Xoff].

Data Bits

The default setting is: [8].

**This item may or may not show up, depending on different configuration.*

Parity

The default setting is: [None].

**This item may or may not show up, depending on different configuration.*

Stop Bits

The default setting is: [1].

**This item may or may not show up, depending on different configuration.*

▶ **PC Health Status**

Press [Enter] to view current hardware health status.

▶ **CPU Configuration**

Press [Enter] to view current CPU configuration and make settings for the following sub-items:

VT-d

Use this item to enable or disable CPU VT-d.

The optional settings: [Enabled]; [Disabled].

EIST

Use this item to enable or disable Intel SpeedStep.

The optional settings: [Disabled]; [Enabled].

C-States

Use this item to enable or disable C State.

The optional settings: [Disabled]; [Enabled].

Enhanced C-states

Use this item to enable or disable C1E. When enabled, CPU will switch to minimum speed when all cores enter C-state.

The optional settings: [Disabled]; [Enabled].

Max Package C State

This item controls Max Package C state that the processor will support.

The optional settings: [PC2]; [PC1]; [C0].

Max Core C State

This item controls the max Core C State that cores will support.

The optional settings: [Fused Value]; [Core C10]; [Core C9] [Core C8]; [Core C 7]; [Core C 6]; [Core C1]; [Unlimited].

▶ **Network Stack Configuration**

Press [Enter] to go to '**Network Stack**' screen to make further settings.

Network Stack

The optional settings are: [Enabled]; [Disabled].

When set as [Enabled], the following sub-items shall appear:

Ipv4 PXE Support

The optional settings are: [Disabled]; [Enabled].

Use this item to enable Ipv4 PXE Boot Support. When set as [Disabled], Ipv4 boot option will not be created.

Ipv6 PXE Support

The optional settings are: [Disabled]; [Enabled].

Use this item to enable Ipv6 PXE Boot Support. When set as [Disabled], Ipv6 boot option will not be created.

PXE Boot Wait Time

Use this item to set wait time to press [ESC] key to abort the PXE boot.

Media Detect Count

Use this item to set number of times presence of media will be checked.

The optional settings range from [1] to [50].

▶ **CSM Configuration**

Press [Enter] to make settings for the following sub-items:

Compatibility Support Module Configuraton

Boot option filter

This item controls Legacy/UEFI ROMs priority.

The optional settings are: [UEFI and Legacy]; [Legacy only]; [UEFI only].

Network

This item controls the execution of UEFI and Legacy PXE OpROM.

The optional settings are: [Do not launch]; [UEFI]; [Legacy].

Storage

This item controls the execution of UEFI and Legacy Storage OpROM.

The optional settings are: [Do not launch]; [UEFI]; [Legacy].

Video

This item controls the execution of UEFI and Legacy Video OpROM.

The optional settings are: [UEFI]; [Legacy].

Other PCI devices

This item determines OpROM execution policy for devices other than Network, storage or video.

The optional settings are: [Do not launch]; [UEFI]; [Legacy].

▶ **Wake-up Function Settings**

Press [Enter] to make settings for the following sub-items:

Wake-up System with Fixed Time

Use this item to enable or disable system wake on alarm event.

The optional settings: [Disabled]; [Enabled].

When set as [Enabled], system will wake on the hour/min/sec specified.

Wake-up System with Dynamic Time

Use this item to enable or disable system wake on alarm event.

System will wake on the current time + Increase minutes.

The optional settings: [Disabled]; [Enabled].

When set as [Enabled], system will wake on the current time + increased minute(s).

USB Wake-up from S4

Use this item to enable or disable USB wake-up from S4.

The optional settings: [Disabled]; [Enabled].

****Note:** This function is supported when ‘**ERP Support**’ is set as [Disabled].

▶ **USB Configuration**

Press [Enter] to make settings for the following sub-items:

USB Configuration

Legacy USB Support

The optional settings are: [Enabled]; [Disabled]; [Auto].

[Enabled]: To enable legacy USB support.

[Disabled]: To keep USB devices available only for EFI specification,

[Auto]: To disable legacy support if no USB devices are connected.

XHCI Hand-off

This is a workaround for OSES without XHCI hand-off support. The XHCI ownership change should be claimed by XHCI driver.

The optional settings are: [Enabled]; [Disabled].

USB Mass Storage Driver Support

The optional settings are: [Disabled]; [Enabled].

USB Hardware Delays and Time-outs:

USB Transfer Time-out

Use this item to set the time-out value for control, bulk, and interrupt transfers.

The optional settings are: [1 sec]; [5 sec]; [10 sec]; [20 sec].

Device Reset Time-out

Use this item to set USB mass storage device start unit command time-out.

The optional settings are: [10 sec]; [20 sec]; [30 sec]; [40 sec].

Device Power-up Delay

Use this item to set maximum time the device will take before it properly reports itself to the host controller.

The optional settings: [Auto]; [Manual].

‘Auto’ uses default value: for a root port it is 100 ms, for a hub port the delay is taken from hub descriptor.

Select [Manual] you can set value for the following sub-item: ‘**Device Power-up Delay in Seconds**’.

Device Power-up Delay in Seconds

The delay range is from [1] to [40] seconds, in one second increments.

- ▶ **Realtek PCIe GBE Family Controller(MAC:XX:XX:XX:XX:XX:XX)**
These items show current network brief information.

3-8 Chipset Menu

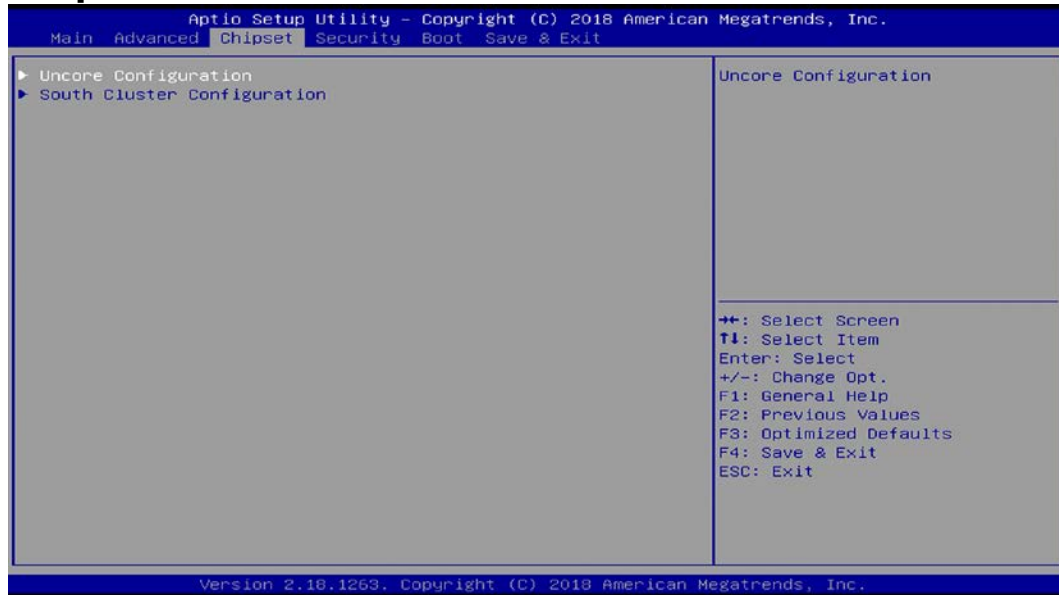

- ▶ **Uncore Configuration**

Press [Enter] to make settings for the following sub-items:

GTT Size

The optional settings are: [2MB]; [4MB]; [8MB].

DVMT Pre-Allocated

Use this item to select DVMT 5.0 pre-allocated (fixed) graphics memory size used by the internal graphics device.

The optional settings are: [64M]; [96M]; [128M]; [160M]; [192M]; [224M]; [256M]; [288M]; [320M]; [352M]; [384M]; [416M]; [448M]; [480M]; [512M].

DVMT Total Gfx Mem

Use this item to select DVMT 5.0 total graphics memory size used by the internal graphics device.

The optional settings are: [128M]; [256M]; [MAX].

Active LFP

The optional settings are: [Disabled]; [Enabled].

When set as **[Disabled], only ‘**Primary IGFX Boot Display**’ shows up, with only one default setting **[Auto]**.*

*When set as **[Enabled]**, both ‘**Primary IGFX Boot Display**’ and ‘**Secondary IGFX Boot Display**’ will show up for user to make further settings. User can also make further settings in ‘**LVDS Panel Type**’ and ‘**LVDS FW Protect**’:*

Primary IGFX Boot Display

Use this item to select the video device which will be activated during POST. This has no effect if external graphics present. Secondary boot display selection will appear based on your selection.

The default setting is: [Auto] when ‘**Active LFP**’ is set as [Disabled].

The optional settings are: [Auto]; [HDMI]; [LVDS] when ‘**Active LFP**’ is set as [Enabled].

Secondary IGFX Boot Display

Secondary boot display selection will appear based on your selection.

The optional settings are: [Disabled]; [HDMI].

LVDS Panel Type

Use this item to select LCD panel used by Internal Graphics Device by selecting the appropriate setup item.

The optional settings are: [800 x 480 1ch 18bit]; [800 x 600 1ch 18bit]; [800 x 600 1ch 24bit]; [1024 x 600 1ch 18bit]; [1024 x 768 1ch 18bit]; [1024 x 768 1ch 24bit]; [1280 x 768 1ch 24bit]; [1280 x 800 1ch 18bit]; [1280 x 800 1ch 24bit]; [1366 x 768 1ch 18bit]; [1366 x 768 1ch 24bit]; [1440 x 900 2ch 18bit]; [1440 x 900 2ch 24bit]; [1280 x 1024 2ch 24bit]; [1680 x 1050 2ch 24bit]; [1920 x 1080 2ch 24bit].

LVDS FW Protect

The optional settings are: [Disabled]; [Enabled].

Memory Information

The working memory information will be on display.

▶ **South Cluster Configuration**

▶ **PCI Express Configuration**

Press [Enter] to make settings for the following sub-items:

Peer Memory Write Enable

The optional settings: [Disabled]; [Enabled].

Compliance Mode

The optional settings: [Disabled]; [Enabled].

Onboard PCIE LAN

The optional settings: [Disabled]; [Enabled].

▶ **SATA Configuration**

Press [Enter] to make settings for the following sub-items:

SATA Controller(s)

The optional settings are: [Enabled]; [Disabled].

When set as [Enabled], the following items shall appear:

SATA Mode Selection

The default setting is: [AHCI].

Use this item to enable or disable each SATA port.

SATA Port

SATA Port

The optional settings: [Disabled]; [Enabled].

M.2

M.2

Use this item to enable or disable M.2 SATA device.

The optional settings: [Disabled]; [Enabled].

HD-Audio Support

Use this item to enable or disable HD-Audio Support.

The optional settings are: [Disabled]; [Enabled].

System State after Power Failure

Use this item to specify what state to go to when power re-applied after a power failure (G3 state).

The optional settings are: [Always On]; [Always Off]; [Former State].

3-9 Security Menu

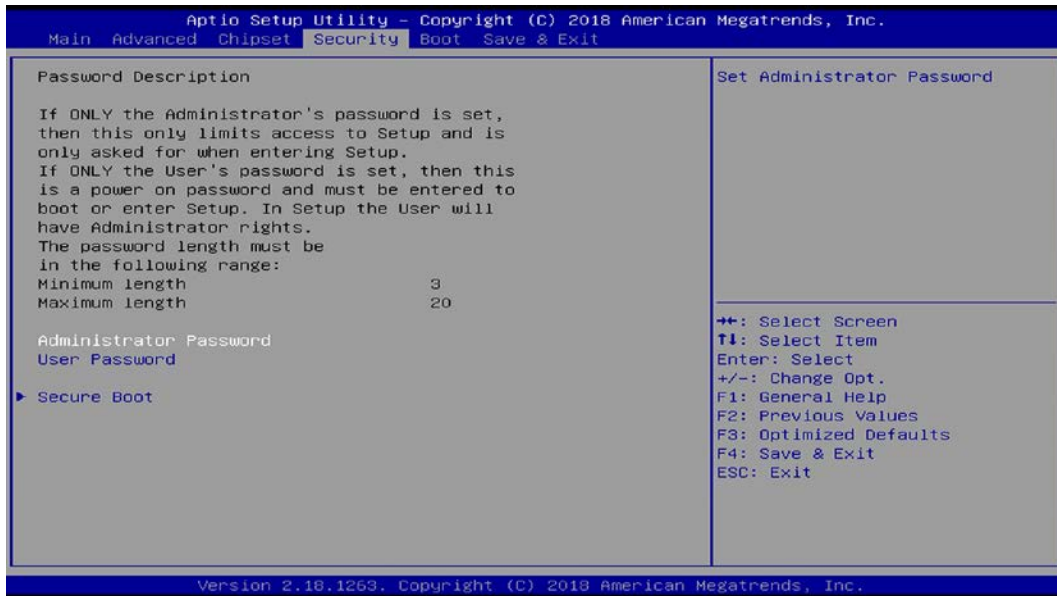

Security menu allow users to change administrator password and user password settings.

Administrator Password

If there is no password present on system, please press [Enter] to create new administrator password. If password is present on system, please press [Enter] to verify old password then to clear/change password. Press again to confirm the new administrator password.

User Password

If there is no password present on system, please press [Enter] to create new administrator password. If password is present on system, please press [Enter] to verify old password then to clear/change password. Press again to confirm the new administrator password.

▶ **Secure Boot**

Press [Enter] to make customized secure settings:

Secure Boot Control

The optional settings are: [Disabled]; [Enabled].

Secure Boot can be enabled if 1. System running in user mode with enrolled Platform Key (PK); 2. CSM function is disabled.

Secure Boot Mode

The optional settings are: [Standard]; [Custom].

Set UEFI Secure Boot Mode to Standard mode or Custom mode. This change is effective after save. After reset, this mode will return to Standard mode.

**When set as [Custom], user can make further settings in 'Key Management'.*

▶ **Key Management**

This item enables experienced users to modify Secure Boot variables, which includes the following items:

Provision Factory Default Keys

This item is for user to install factory default secure boot keys when system is in Setup Mode.

The optional settings are: [Disabled]; [Enabled].

▶ **Enroll all Factory Default Keys**

This item forces system to User Mode-install all Factory Default keys.

▶ **Save all Secure Boot Variables**

This item will save NVRAM content of all Secure Boot variables to the files (WFI_SIGNATURE_LIST data format) in root folder on a target file system device.

▶ **Platform Key (PK)/Key Exchange Keys/Authorized Signature/Forbidden**

Signature/ Authorized TimeStamps/OS Recovery Signatures

Use this item to enroll Factory Defaults or load the keys from a file with:

1. Public Key Certificate in:
 - a) EFI_SIGNATURE_LIST
 - b) EFI_CERT_X509 (DER encoded)
 - c) EFI_CERT_RSA2048 (bin)
 - d) EFI_CERT_SHA256 (bin)
2. Authenticated UEFI Variable

3-10 Boot Menu

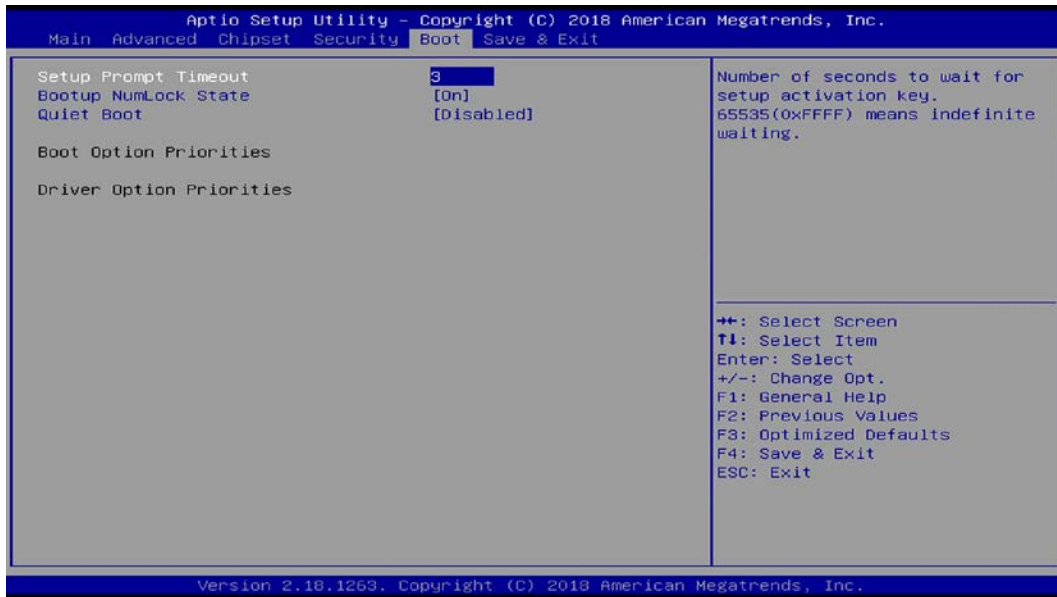

Setup Prompt Timeout

Use this item to set number of seconds to wait for setup activation key.

Bootup Numlock State

Use this item to select keyboard numlock state.

The optional settings are: [On]; [Off].

Quiet Boot

The optional settings are: [Disabled]; [Enabled].

Boot Option Priorities

Boot Option #1/ Boot Option #2...

Use this item to decide system boot order from available options.

3-11 Save & Exit Menu

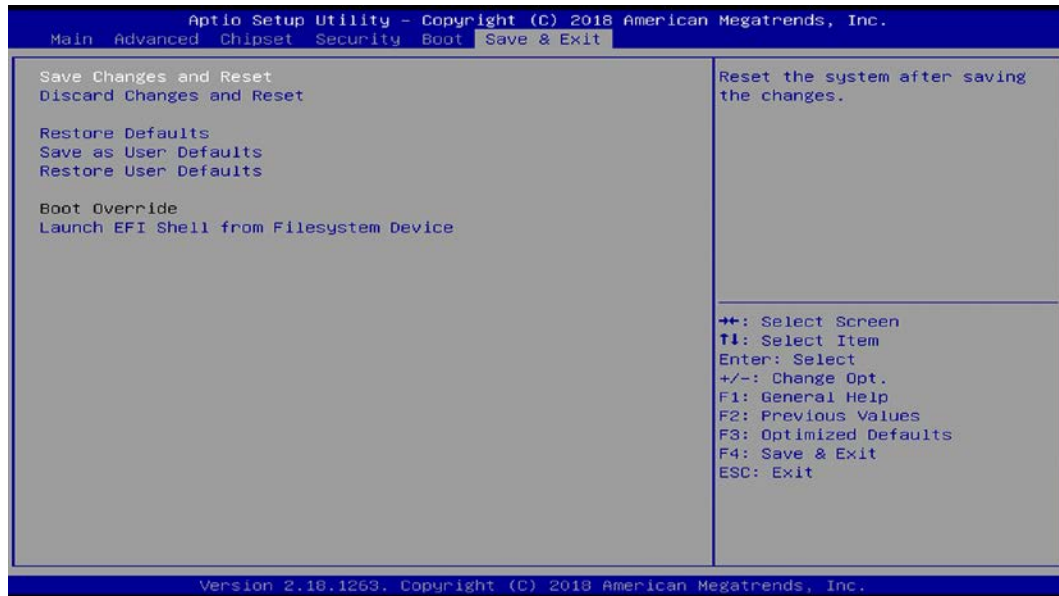

Save Changes and Reset

This item allows user to reset the system after saving the changes.

Discard Changes and Reset

This item allows user to reset the system without saving any changes.

Restore Defaults

Use this item to restore /load default values for all the setup options.

Save as User Defaults

Use this item to save the changes done so far as user defaults.

Restore User Defaults

Use this item to restore defaults to all the setup options.

Boot Override

The available options here are dynamically updated and make system boot to any boot option selected.

Launch EFI Shell from filesystem device

Use this item to launch EFI shell application (shell.efi) from one of the available filesystem device.